



647946 EN-USM1 (E-04/2024)

MT 730 H 75K ST5 S1
MT 930 H 75K ST5 S1

OPERATOR'S MANUAL
(ORIGINAL MANUAL)

IMPORTANT

Carefully read and understand this instruction manual before using this machine.

It contains all information relating to operation, handling and equipment, as well as important recommendations to be followed.

This document also contains precautions for use, as well as information on the service and routine maintenance required to ensure the machine's continued reliability and safety of use.

WHenever you see this symbol, it means:



PLEASE NOTE! BE CAREFUL! YOUR SAFETY, THAT OF OTHERS, OR THE SAFETY OF THE MACHINE IS AT RISK.

- This manual has been produced based on the equipment list and technical characteristics given at the time of its design.
- The machine's equipment level depends on the options chosen and the country of sale.
- Depending on the machine's options and the date of sale, certain equipment or functions described in this manual may not be present on this machine.
- Descriptions and figures are non-binding.
- MANITOU reserves the right to change its models and their equipment without being required to update this manual.
- The MANITOU network, consisting exclusively of qualified professionals, is available to answer all your questions.
- This manual is an integral part of the machine.
- It is to be kept in its storage location at all times for ease of reference.
- Give this manual to the new owner if the machine is resold.

1 st EDITION	A-04/2021	
UPDATED	B-07/2021	2-12 ; 2-14 ; 2-17 ; 2-19 ; 2-29 ; 2-31 ; 2-36 ; 2-44 ; 2-49 ; 2-62 ; 3-10
	C-11/2022	0-0
		1-1 – 1-34
		2-4 ; 2-11 ; 2-36 ; 2-37 ; 2-44 ; 2-73 – 2-75
		3-9 ; 3-11 ; 3-35 ; 3-40
	D-12/2023	1-1 – 1-34
		4-6
	E-04/2024	1-1 – 1-34
		4-6 – 4-10

The brochure and all its contents, including diagrams, are the proprietary and confidential intellectual property of Manitou BF and / or its subsidiaries ("Manitou Group"). Any reproduction, publication or dissemination of any part of the brochure without the express written authorization of Manitou Group is strictly prohibited. Any violation of this provision will subject the offending party to prosecution by Manitou Group to the fullest extent of the law. The logos and the company's visual identity are the property of Manitou Group and may not be used without the express written authorization of Manitou Group.

All trademarks, registered and unregistered, is and shall remain the property of Manitou BF or its respective owner.

Any reproduction, source code access, decompilation, modification, copy (other than backup copies), correction of errors, transmission or distribution of any software built into Manitou Group machines is strictly prohibited.

In the event that the measures above nevertheless prove essential to enable use of the software, in accordance with its destination, or to obtain the information required for interoperability with other software created independently, the user should contact Manitou Group in advance and Manitou may, at its sole discretion, take the necessary measures or give access to only the information strictly necessary for interoperability.

Any breach of these requirements is likely to constitute a counterfeiting offense subject to legal action by Manitou Group.

Connected Manitou Group machines are equipped with boxes that collect technical data on the machines (such as geo-tracking data or data on component operation). This data, which is organized, processed and enhanced by algorithms and expertise proprietary to Manitou Group, constitutes, in combination with other elements, independent or not, a protected database according to laws & regulations on IP purposes.

It is strictly forbidden to have access to all or part of this database and to use the data (including in the event of accidental access) without explicit prior authorization from Manitou Group. In the event that Manitou Group authorizes a Manitou Group machine user to access all or part of this database, Manitou Group, as producer of this database, cedes to the user only a right to personal, non-exclusive, non transferable use of the database, and only by access to an information technology platform hosted by a server owned or controlled by Manitou Group.

In any case, the following are strictly prohibited:

- any extraction, reproduction, representation, reuse through provision to the public, distribution, transfer, permanent or temporary, on any medium, by any means, and in any form whatsoever, of all or of a qualitatively or quantitatively substantial part of the contents of this database,*
- any extraction, reproduction, representation, reuse through provision to the public, distribution, transfer, repeated or systematic of qualitatively or quantitatively insubstantial parts of the content of the database during operations manifestly exceeding normal use of the database by the user of the machine for his own needs,*
- any use of means to bypass technical protection measures for databases or software source code embedded in the boxes, in keeping according to laws & regulations on IP purposes.*

The latest updated version in force and binding of this document is the version available on demand.

Only the electronic version is maintained.

MANITOU BF S.A. Public limited company with a board of directors.

Head office: 430 rue de l'Aubinière - 44150 Ancenis - France

Share capital: €39,548,949

Entered in the Nantes Trade and Companies Register under number 857 802 508.

Tel.: +33 (0) 2 40 09 10 11

www.manitou.com

1 - OPERATING AND SAFETY INSTRUCTIONS

2 - DESCRIPTION

3 - MAINTENANCE

4 - ATTACHMENTS



1 - OPERATING AND SAFETY INSTRUCTIONS

1 - OPERATING AND SAFETY INSTRUCTIONS

INSTRUCTIONS TO THE COMPANY MANAGER

1-4

THE SITE	1-4
THE OPERATOR	1-4
THE MACHINE	1-4
A - SUITABILITY OF THE MACHINE FOR THE TASK	1-4
B - ADAPTING THE MACHINE TO USUAL ENVIRONMENTAL CONDITIONS	1-4
C - MODIFYING THE MACHINE	1-5
D - FRENCH ROAD TRAFFIC RULES	1-5
E - MACHINE CAB PROTECTION	1-5
INSTRUCTIONS	1-6
MAINTENANCE	1-6

INSTRUCTIONS FOR THE OPERATOR

1-8

FOREWORD	1-8
GENERAL INSTRUCTIONS	1-8
A - OPERATOR'S MANUAL	1-8
B - AUTHORIZATION FOR USE IN FRANCE	1-8
C - MAINTENANCE	1-8
D - TIRES	1-9
E - MODIFYING THE MACHINE	1-9
F - LIFTING PEOPLE	1-9
OPERATING INSTRUCTIONS UNLADEN AND LADEN	1-10
A - BEFORE STARTING UP THE MACHINE	1-10
B - AVAILABLE IN THE DRIVER'S CAB	1-10
C - ENVIRONMENT	1-10
D - VISIBILITY	1-11
E - STARTING THE MACHINE	1-12
F - OPERATING THE MACHINE	1-12
G - STOPPING THE MACHINE	1-14
H - DRIVING THE MACHINE ON THE PUBLIC HIGHWAY	1-15
INSTRUCTIONS FOR HANDLING A LOAD	1-18
A - CHOICE OF ATTACHMENTS	1-18
B - WEIGHT OF LOAD AND CENTER OF GRAVITY	1-18
C - LONGITUDINAL STABILITY LIMITER AND WARNING DEVICE	1-18
D - TRANSVERSE ATTITUDE OF THE MACHINE	1-19
E - PICKING UP A LOAD ON THE GROUND	1-19
F - PICKING UP AND PUTTING DOWN A HIGH LOAD ON TIRES	1-20
G - PICKING UP AND PUTTING DOWN A HIGH LOAD ON STABILIZERS	1-22
H - PICKING UP AND PUTTING DOWN A SUSPENDED LOAD	1-24
I - TRAVELING WITH A SUSPENDED LOAD	1-24
INSTRUCTIONS FOR USE AS A LOADER	1-25
A - LOADING	1-25
B - BACKFILLING	1-25
INSTRUCTIONS FOR USING THE MOBILE ELEVATING WORK PLATFORM	1-26
A - AUTHORIZATION FOR USE	1-26
B - SUITABILITY OF THE PLATFORM FOR THE JOB	1-26
C - PROVIDED ON THE PLATFORM	1-26
D - USING THE PLATFORM	1-27
E - ENVIRONMENT	1-28
F - MAINTENANCE	1-28
INSTRUCTIONS FOR USING THE RADIO-CONTROL	1-29
HOW TO USE THE RADIO-CONTROL	1-29
PROTECTIVE DEVICES	1-29

MACHINE MAINTENANCE INSTRUCTIONS

1-30

GENERAL INSTRUCTIONS	1-30
PLACING THE JIB SAFETY WEDGE	1-30
FITTING THE WEDGE	1-30
REMOVING THE WEDGE	1-30
FITTING THE WEDGE	1-30
REMOVING THE WEDGE	1-30
MAINTENANCE	1-31
MAINTENANCE LOGBOOK	1-31
LUBRICANT AND FUEL LEVELS	1-31
HYDRAULICS	1-31
ELECTRICITY	1-31
WELDING ON THE MACHINE	1-31
WASHING THE MACHINE	1-32
TRANSPORTING THE MACHINE	1-32

PROLONGED MACHINE SHUTDOWN

1-32

INTRODUCTION	1-32
PREPARATION OF THE MACHINE	1-32
DEF (Diesel Exhaust Fluid) TANK	1-32
PROTECTING THE ENGINE	1-33
MACHINE PROTECTION	1-33
RETURNING THE MACHINE TO SERVICE	1-33

DISPOSING OF THE MACHINE

1-34

RECYCLING OF MATERIALS	1-34
METALS	1-34
PLASTICS	1-34
RUBBER	1-34
GLASS	1-34
ENVIRONMENTAL PROTECTION	1-34
WORN OR DAMAGED PARTS	1-34
USED OIL	1-34
USED BATTERIES.	1-34

INSTRUCTIONS TO THE COMPANY MANAGER

THE SITE

Proper management of the machine's area of travel will reduce the risk of accidents:

- ground not unnecessarily uneven or obstructed,
- no excessive slopes,
- pedestrian traffic controlled, etc.

THE OPERATOR

- Only qualified, authorized personnel can use the machine. This authorization is given in writing by the appropriate person in the establishment where the machine is to be used and must be carried permanently by the operator.

⚠ IMPORTANT ⚠

Experience has shown that there are a number of inappropriate ways in which the machine might be operated. Such foreseeable misuse, of which the main examples are listed below, are strictly forbidden.

- The foreseeable abnormal behavior resulting from ordinary negligence, but not from any intentional misuse of the equipment.

- The reflex reactions of a person in the event of a malfunction, incident, fault, etc. during operation of the machine.

- Behavior resulting from application of the "principle of least effort" when performing a task.

- For certain machines, the foreseeable behavior of such persons as: apprentices, teenagers, handicapped persons, trainees tempted to drive a machine, operators tempted to operate a machine to win a bet, in competition or for their own personal experience.

The person in charge of the equipment must take these criteria into account when assessing whether or not a person will make a suitable driver.

THE MACHINE

A - SUITABILITY OF THE MACHINE FOR THE TASK

- MANITOU has ensured that this machine is suitable for use under the standard operating conditions defined in this operator's manual, with a **STATIC TEST COEFFICIENT OF 1.25** and a **DYNAMIC TEST COEFFICIENT OF 1**, as specified in harmonized standard **EN 1459** for variable reach machines.
- Before commissioning, the facility manager must make sure that the machine is appropriate for the work to be done, and perform certain tests (in accordance with applicable legislation).

B - ADAPTING THE MACHINE TO USUAL ENVIRONMENTAL CONDITIONS

⚠ IMPORTANT ⚠

For operation under average climatic conditions, i.e. between -15 °C and +35 °C, correct levels of lubricants in all the circuits are checked in production. -15 °C to +35 °C

For operation under more severe climatic conditions, before starting up, drain all circuits then fill using lubricants suitable for the ambient temperatures.

The same applies to the coolant.

⚠ IMPORTANT ⚠

The machines are designed for outdoor use under normal atmospheric conditions and indoor use in suitably aerated and ventilated premises. It is prohibited to operate the machine in areas which presents a risk of fire or which are potentially explosive (e.g. refineries, fuel or gas depots, stores of flammable products, etc.).

Specialized equipment is available when operating in these areas (ask your dealer for information).

- Our machines are designed to be used within a temperature range of -18 °C to +43 °C.
- In addition to the standard equipment fitted on your machine, many options are available, such as: road lighting, stop lights, rotating beacon light, reverse lights, front worklight, rear worklight, lifting structure worklight, etc. (depending on machine model).
- The operator must take into account the operating conditions to specify the machine's signaling and lighting equipment. Consult your dealer.
- Take into account the climatic and atmospheric conditions of the operation site. Consult your dealer for the suitability of lubricants and frost protection.
- Take into account the fire risk associated with use in dusty and flammable conditions (e.g. straw, flour, sawdust, organic waste, etc.).
- A machine operating in an area without fire extinguishing equipment must be equipped with an individual extinguisher. Solutions exist, consult your dealer.

Our machines comply with Directive 2014/30/EU (2015/208/EU for our type-approved "TRACTOR" machines) concerning electromagnetic compatibility (EMC), (UK : Electromagnetic Compatibility Regulations 2016) and with the corresponding harmonized standard EN 12895. Their correct operation is no longer guaranteed if they are used within areas in which the electromagnetic fields exceed the limit specified by this standard (20 V/m).

- Directive 2002/44/EC requires company managers to not expose their employees to excessive vibration doses. There is no recognized code of measurement for comparing the machines of different manufacturers. The actual doses received cannot therefore be measured under actual operating conditions at the user's premises.
- The following are some tips for minimizing these vibration doses:
 - Select the most suitable machine and attachment for the intended use.
 - Adapt the seat adjustment to the operator's weight (**depending on machine model**) and maintain it in good condition, as well as the cab suspensions. Inflate the tires in accordance with recommendations.
 - The seat is an essential way of reducing the vibrations transmitted to the operator. In the event of seat replacement, please contact MANITOU.
 - Ensure that the operators adapt their operating speed to suit the conditions on site.
 - As far as possible, arrange the site in such a way as to provide a flat running surface and remove obstacles and harmful potholes.

C - MODIFYING THE MACHINE



Modifying the structure and settings of the various components of your machine (hydraulic pressure, taring of limiters, engine speed, sensors, addition of extra equipment, addition of counterweights, unapproved and unauthorized attachments, alarm systems, etc.) yourself is strictly prohibited. In this case, the manufacturer cannot be held responsible.

D - FRENCH ROAD TRAFFIC RULES

(or see current legislation in other countries)

- Only one EC declaration of conformity is issued. It must be kept in a safe place.
- The road traffic rules for the machines are subject to the provisions of the highway code, according to the following categories:
 - Construction machinery (MT range): public works vehicle not predominantly for use on roads (point 6.9 of Article R.311-1 of the French Highway Code). The machine must have a 25 disc displayed on the rear of the machine and an operating license plate.
 - Non-type-approved "Tractor" machinery for agricultural work: (point 6.2 of Article R.311-1 of the French Highway Code). The machine must be fitted with an operating license plate.
 - Type-approved "Tractor" machinery for agricultural work: Agricultural tractor type T1a (point 5.1.1 of Article R.311-1 of the French Highway Code). The machine must be licensed.

SPECIAL INSTRUCTIONS APPLICABLE TO TYPE-APPROVED "TRACTOR" MACHINES

- All approved machines are supplied with a "Tractor" certificate of compliance with Regulation 167/2013, to be retained by the owner, and a page of administrative details together with a CNIT number (national type approval code) for registration at the prefecture.
- The owner of the machine is responsible for carrying out the necessary procedures for obtaining the vehicle registration document within the time limit defined by the regulations.
- The operator must hold a category B driver's license, unless granted an exemption.
- The machine must be driven on the public highway in accordance with the instructions given in the manual supplied with the machine (Gross weight, Gross combination weight, towing load, axle loads, maximum speeds, etc. according to the type/version). The operator must be in possession of the machine's registration document.



**When towing a trailer or agricultural equipment, the traveling speed of the machine is limited to 25 km/h.
In this case, a "25" disc must be affixed to the rear of the convoy.**

E - MACHINE CAB PROTECTION

- All machines comply with standard ISO 3471 Roll-over Protective Structures (ROPS)
- All machines comply with standard ISO 3449 Falling-Object Protective Structures (FOPS) (Level I or II) (↖ 2 - DESCRIPTION OF STICKERS AND PLATES)
- The windows used on our machines comply with standard ECE-R43 Operator Protective Structures (OPS).
- Approved "TRACTOR" machines also comply with the regulations:
 - (appendix 1322/2014-OCDE Code 4).
 - (appendix 1322/2014-OCDE Code 10).



**Structural damage or overturning, a modification, changes or a poorly executed repair can reduce the protective efficiency of the cab, canceling its compliance.
Do not perform welding or drilling on the cab structure.
Consult your dealer to determine the limits of this structure without canceling its compliance.**

INSTRUCTIONS

- The operator's manual must always be in good condition, in the language of the operator and placed in the storage compartment provided.
- The operator's manual and any plates or stickers which are no longer legible or are damaged, must be replaced immediately.

MAINTENANCE

⚠ IMPORTANT ⚠

Refer to chapter: MACHINE MAINTENANCE INSTRUCTIONS.

⚠ IMPORTANT ⚠

Your machine must be periodically inspected to ensure its continued compliance.

The frequency of this inspection is defined by the legislation in force in the country in which the machine is used.

- Maintenance or repairs other than those detailed in Part: 3 - MAINTENANCE must be carried out by qualified personnel (consult your dealer) and in the necessary safety conditions to preserve the health of the operator and any third party.
- Example for France "The manager in charge of the establishment using a machine must open and maintain a maintenance log for each machine (order of March 2, 2004) and undergo a general periodic inspection every 6 months (order of March 1, 2004)".

INSTRUCTIONS FOR THE OPERATOR

FOREWORD

⚠ IMPORTANT ⚠

The risk of accident while using, servicing or repairing this machine can be reduced if you follow the safety instructions and preventive measures detailed in this instruction manual.

Failure to respect the safety and operating instructions, or the instructions for repairing or servicing your machine may lead to serious, even fatal accidents.

⚠ IMPORTANT ⚠

In order to reduce or prevent any danger with a MANITOU-approved attachment, follow the instructions in paragraph: 4 - ADAPTABLE ATTACHMENTS AVAILABLE ON THE RANGE: INTRODUCTION.

- Only the operations and maneuvers described in these operator's manual must be performed. The manufacturer cannot predict all possible risky situations. Consequently, the safety instructions given in the operator's manual and on the machine itself are not exhaustive.
- At all times, as an operator, you must envisage, within reason, the possible risk to yourself, to others or to the machine when you use it.
- The operator is responsible for the machine in all circumstances, regardless of whether he is present in the driver's cab.

GENERAL INSTRUCTIONS

A – OPERATOR'S MANUAL

⚠ IMPORTANT ⚠

Carefully read and understand this operator's manual before operating this machine.

- The operator's manual must always be in good condition, in the language of the operator and placed in the storage compartment provided.
- Any operations or maneuvers not described in the operator's manual are proscribed.
- Follow the safety advice and the instructions described on the machine's stickers.
- Familiarize yourself with the machine on the ground where it will be operated.
- You must replace the instruction manual, as well as any plates or stickers, if they are no longer legible or are missing or damaged.

B - AUTHORIZATION FOR USE IN FRANCE

(or see current legislation in other countries).

- Only qualified, authorized personnel can use the machine. This authorization is given in writing by the appropriate person in the establishment where the machine is to be used and must be carried permanently by the operator.
- The operator is not empowered to authorize the driving of the machine by another person.

C - MAINTENANCE

- If the operator sees that the machine is not in good working order or does not comply with the safety instructions, he must inform his manager of this immediately.
- The operator is prohibited from carrying out any repairs or adjustments himself, unless he has been trained for this purpose. He must keep the machine properly cleaned if this is his responsibility.
- The operator must carry out the daily maintenance (↖ 3 - MAINTENANCE) before using the machine in his place of work.
- The operator is responsible for deciding and adjusting the frequency and type of the cleaning needed to prevent the risk of fire ensuing from the build-up of flammable material(s). The operator should pay special attention to all the areas of the machine where these high-risk materials are likely to accumulate (e.g. engine compartment, under the lifting structure, above the axles, inside the chassis, etc.).

D - TIRES

⚠ IMPORTANT ⚠

Do not use the machine if the wheels are damaged or excessively worn, because this could put your own safety or that of others at risk, or cause damage to the machine.

- The operator must ensure tires are suitable for the nature of the ground (see contact surface with the ground for the tires in the chapter: 2 - DESCRIPTION: TIRES). Optional solutions are available, please consult your dealer.
 - SAND tires.
 - FARM tires.
 - Snow chains.
- The machine's four tires must be the same brand, the same dimensions, the same structure (radial or diagonal) and the same usage category (normal, snow or special), and must have the same degree of tread wear.
- In the event of tire replacement, use tires authorized by MANITOU that are the same type and dimensions. Using different tires voids the machine's type approval and you may be liable.
- If you are replacing just one of the machine's tires (e.g. because it is damaged), we recommend choosing a tire with the same degree of wear as the remaining tires so as not to damage the transmission's kinematic chain.

⚠ IMPORTANT ⚠

*Do not use the machine if the tires are damaged or excessively worn, because this could put your own safety or that of others at risk, or cause damage to the machine itself.
The fitting of foam inflated tires is prohibited and is not guaranteed by the manufacturer unless with prior authorization.*

E - MODIFYING THE MACHINE

- < INSTRUCTIONS TO THE COMPANY MANAGER: < C - MODIFYING THE MACHINE.

F - LIFTING PEOPLE

- The use of working equipment and load lifting attachments to lift people is:
 - either forbidden
 - or authorized exceptionally and under certain conditions (< regulations in force in the country in which the machine is used).
- The pictogram posted at the operator station reminds you that:
 - Left-hand column
 - It is forbidden to lift people, with any kind of attachment, using a non PLATFORM-fitted machine.
 - Right-hand column
 - With a PLATFORM-fitted machine, people can only be lifted using platforms designed by MANITOU for this purpose.
- MANITOU sells equipment specifically designed for lifting people (OPTION PLATFORM-fitted machine; contact your dealer).

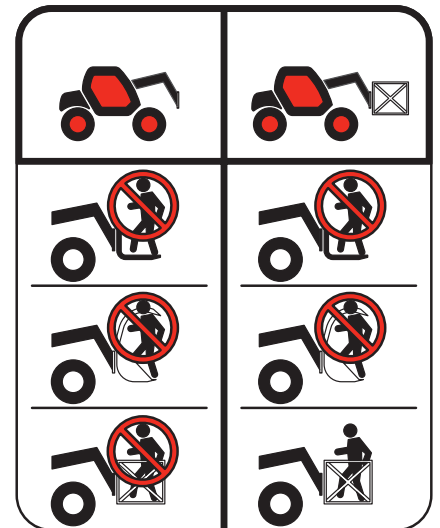

A - BEFORE STARTING UP THE MACHINE

- Perform the daily maintenance operations (< 3 - MAINTENANCE).
- Make sure that the driver's cab is clean, particularly the floor and floor mat. Check that no movable object may hinder the operation of the machine.
- Make sure the lights, turn signals and windshield wipers are working properly.
- Make sure the rear-view mirrors are in good condition, clean and properly adjusted.
- Make sure the horn works.

B - AVAILABLE IN THE DRIVER'S CAB

- Whatever his experience, the operator is advised to familiarize himself with the position and operation of all the controls and instruments before operating the machine.
- Wear clothes suitable for driving the machine, avoid loose clothing.
- Make sure you have the appropriate protective equipment for the task to be performed.
- Prolonged exposure to high noise levels may cause hearing problems. It is recommended to wear ear muffs to protect against excessive noise.
- Always face the driver's cab access when getting in and out of the lift truck and use the handle(s) provided for this purpose. Do not jump out of the machine.
- Remain alert at all times when using the machine. Do not listen to the radio or music using headphones or earphones.
- Never operate the lift truck when hands or feet are wet or soiled with greasy substances.
- For increased comfort, adjust the seat to your requirements and adopt the correct position in the driver's cab.



Under no circumstances must the seat be adjusted while the machine is moving.

- The operator must always be in his normal position in the driver's cab: Arms and legs, and generally any part of the body, should be kept inside the driver's cab of the machine.
- The safety belt must be worn and adjusted to the operator's size.
- The control units must never be used for any other than their intended purposes (e.g. Climbing onto or down from the machine, coat hanger, etc.).
- If the control components are fitted with a forced operation (lever lock) device, it is forbidden to leave the cab without first putting these controls in neutral.
- It is prohibited to carry passengers either on the machine or in the cab.

C - ENVIRONMENT

- Comply with site safety regulations.
- If you have to use the machine in a dark area or work at night, make sure it is equipped with work lights.
- During handling operations, make sure that no one is in the way of the machine and its load.
- Do not allow anybody to come near the working area of the machine or pass beneath an elevated load.
- The maximum slope on which the machine can be used in relation to the capacity of the brake is 20%.
- When using the lift truck on a transverse slope, before lifting the lifting structures, observe the instructions given in the paragraph: INSTRUCTIONS FOR HANDLING A LOAD: D - TRANSVERSE ATTITUDE OF THE MACHINE.
- Traveling on a longitudinal slope:
 - Drive and brake gently.

- Moving without load: Forks or attachment facing downhill.

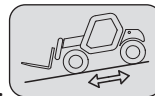

- Moving with load: Forks or attachment facing uphill.

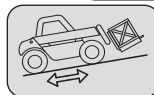

- Take into account the machine's dimensions and its load before trying to negotiate a narrow or low passageway.
- Never move onto a load bridge without having first checked:
 - That it is suitably positioned and made fast.
 - That the unit to which it is connected (wagon, truck, etc.) will not shift.
 - That this bridge is prescribed for the total weight of the machine, laden or unladen.
 - That this bridge is prescribed for the size of the machine.

- Never move onto a foot bridge, floor or freight lift, without being certain that they are suitable for the weight and size of the machine, laden or otherwise, and without having checked that they are in sound working order.
- Be careful in the area of loading bays, trenches, scaffolding, soft ground and manholes.
- Make sure the ground is stable and firm under the wheels and/or stabilizers before lifting or removing the load. If necessary, add appropriate wedging under the stabilizers.
- Make sure that the scaffolding, loading platform, pilings or ground is capable of bearing the load.
- Never stack loads on uneven ground, they may tip over.

⚠ IMPORTANT ⚠

If the load or the attachment must remain above a structure for a prolonged period of time, there is the risk that it will bear on the structure as the lifting structure descends due to cooling of the oil in the cylinders.

To eliminate this risk:

- *Regularly check the distance between the load or the attachment and the structure and readjust this if necessary.*
- *If possible use the machine at an oil temperature as close as possible to ambient temperature.*

- In the case of work near to overhead lines, ensure that the safety distance is sufficient between the machine's working area and the overhead line.

⚠ IMPORTANT ⚠

Do not operate this machine during thunderstorms, snowstorms, periods of frost, or in hazardous weather conditions.

⚠ IMPORTANT ⚠

You must consult your local electrical supplier.

You could be electrocuted or seriously injured if you operate or park the machine too close to power lines.

In the event of high winds, do not carry out handling work that jeopardizes the stability of the machine and its load, particularly if the load catches the wind badly.

- Prevent the fire risk associated with use in dusty and flammable conditions (e.g. straw, flour, sawdust, organic waste, etc.).

D - VISIBILITY

- The safety of people within the machine's working area, as well as that of the machine itself and the operator, are dependent on good operator visibility of the machine's immediate surroundings in all situations and at all times.
- This machine has been designed to allow good operator visibility (direct or indirect by means of rear-view mirrors) of the immediate surroundings of the machine while driving with no load and with the boom in the transport position.
- Special precautions must be taken if the size of the load restricts visibility towards the front:
 - moving in reverse,
 - site layout,
 - assisted by a person directing the operation (while standing outside the machine's area of travel), making sure to keep this person clearly in view at all times,
 - in any case, avoid reversing over long distances.
- Certain special accessories may require the machine to travel with the boom in the raised position. In such cases, visibility on the right hand side is restricted, and special precautions must be taken:
 - site layout,
 - assisted by a person directing the operation (while standing outside the machine's area of travel).
 - replacement of a suspended load by a load on a pallet.
- If visibility of your road is inadequate, ask someone to assist by directing the operation (while standing outside the machine's area of travel), making sure to keep this person clearly in view at all times.
- Keep all components affecting visibility in a clean, properly adjusted state and in good working order (e.g. windshields, windows, windshield wipers, windshield washers, driving lights and worklights, rear-view mirrors).

E - STARTING THE MACHINE

SAFETY INSTRUCTIONS

⚠ IMPORTANT ⚠

The machine must only be started up or maneuvered when the operator is sitting in the driver's cab with seat belt fastened and adjusted.

- Never try to start the machine by pushing or towing it. Such an operation may cause severe damage to the transmission. If necessary, towing requires the transmission to be put in neutral (↩ 3 - MAINTENANCE).
- If using an emergency battery for start-up, use a battery with the same characteristics and respect battery polarity when connecting it. Connect at first the positive terminals before the negative terminals.

⚠ IMPORTANT ⚠

*Failure to respect polarity between batteries can cause serious damage to the electrical circuit.
The electrolyte in the battery may produce an explosive gas. Avoid flames and generation of sparks close to the batteries.
Never disconnect a battery while it is in charge.*

INSTRUCTIONS

- Check the closing and locking of the hood(s).
- Check that the cab door is closed.
- Firmly press and hold down the brake pedal.
- Turn the ignition key to position (I) to switch on the machine and the engine preheat system.
- Check that the forward/reverse selector is in neutral, and that the manual parking brake is on.
- Check the fuel level on the dashboard gauge.
- Check the DEF (diesel exhaust fluid) level on the dashboard gauge. (depending on machine model)
- Turn the ignition key to position (III) for no longer than 15 seconds. The engine should then start. Release the ignition key and let the engine run at idling speed.
- Preheat the engine between each start attempt.
- Make sure all the signal lights on the control instrument panel are off.
- Check the longitudinal stability limiter and warning device (↩ 3 - MAINTENANCE).
- Do not use a machine that is non-compliant.
- Check all control instruments when the engine is warm and at regular intervals during use, so as to quickly detect any faults and to be able to correct them without any delay.
- If an instrument does not show the correct display, stop the engine and immediately carry out the necessary operations.

F - OPERATING THE MACHINE

SAFETY INSTRUCTIONS

⚠ IMPORTANT ⚠

We would like to draw the operators' attention to the risks involved in using the machine, in particular:

- Risk of losing control.

- Risk of loss of lateral and frontal stability of the machine.

The operator must remain in control of the machine.

In the event of the machine overturning, do not try to leave the cab during the incident.

YOUR BEST PROTECTION IS TO STAY FASTENED IN THE CAB.

- Observe the company's traffic regulations or, by default, the public highway code.
- Do not carry out operations which exceed the capacities of your machine or attachment.
- Always drive the machine with the forks or attachment in the transport position, i.e., 300 mm from the ground, the boom retracted and the forks carriage sloping backwards.
- Only carry loads which are balanced and properly anchored to avoid any risk of a load falling off.
- Ensure that pallets, cases, etc. are in good order and suitable for the load to be lifted.
- Familiarize yourself with the machine on the terrain where it will be used.
- Ensure that the brakes are working properly.
- The loaded machine must not travel at speeds in excess of 12 km/h.
- Drive smoothly at an appropriate speed for the operating conditions (land configuration, load on the machine).
- Do not use the hydraulic boom controls when the machine is moving.
- Never change the steering mode whilst driving.
- Ensure that visibility is adequate.
- Do not maneuver the machine with the boom in the raised position unless under exceptional circumstances and then with extreme caution, at very low speed and using gentle braking.
- Take bends slowly.

- In all circumstances make sure you are in control of your speed.
- On damp, slippery or uneven terrain, drive slowly.
- Brake gently, never abruptly.
- Only use the machine's forward/reverse selector from a stationary position and never do so abruptly.
- Do not drive with your foot on the brake pedal.
- Always remember that hydrostatic type steering is extremely sensitive to movement of the steering wheel, so turn it gently and not jerkily.
- Never leave the engine on when the lift truck is unattended.
- Do not leave the cab when the machine has a raised load.
- Look where you are going and always make sure you have good visibility along the route.
- Use the rear-view mirrors frequently.
- Drive around obstacles.
- Never drive on the edge of a ditch or steep slope.
- It is dangerous to use two machines simultaneously to handle heavy or bulky loads, since this operation requires particular precautions to be taken. It must only be used exceptionally and after risk analysis.
- The ignition switch has an emergency stop mechanism in case of an operating anomaly occurring in the case of machines not fitted with a punch-operated cut-out.

INSTRUCTIONS

- Always drive the machine with the forks or attachment in the transport position, i.e., 300 mm from the ground, the telescopic arm retracted and the forks carriage sloping backward.
- For machines with gearboxes, use the recommended gear (↩ 2 - DESCRIPTION: INSTRUMENTS AND CONTROLS).
- Select the steering mode appropriate for the use and/or working conditions (↩ 2 - DESCRIPTION: INSTRUMENTS AND CONTROLS) (depending on machine model).
- Deactivate the parking brake.
- Shift the forward/reverse selector to the selected direction of travel and accelerate gradually until the machine moves off.

⚠ IMPORTANT ⚠

Starting and moving the machine on a slope may be a real hazard.

If the machine is parked or stopped, adhere scrupulously to the following instructions for moving it:

- Press the brake pedal.

- Release the parking brake.

- Engage the appropriate gear. (depending on machine model)

- Select forward or reverse direction.

- Ensure that there is no one or anything impeding the movement of the machine.

- Release the brake pedal and accelerate the engine.

The use of the machine loaded or with a trailer increases the risk. In this case, remain extremely vigilant.

Each braking system operates independently.

In an emergency, use the brake pedal and/or the manual parking brake to immobilize the machine.

With the engine off, release the manual parking brake only after restarting the engine and making sure that the brake pedal is functional.

G - STOPPING THE MACHINE

SAFETY INSTRUCTIONS

- Never leave the ignition key in the machine during the operator's absence.
- When the machine is stationary, or if the operator has to leave his cab (even for a moment), place the forks or attachment on the ground, apply the parking brake and place the forward/reverse selector in neutral.
- Make sure that the machine is not stopped in any position that will interfere with the traffic flow and at less than one meter from the track of a railway.
- In the event of prolonged parking on a site, protect the machine from bad weather, particularly from frost (check the level of antifreeze), and close and lock all the machine accesses (doors, windows, cowls, etc.).

INSTRUCTIONS

- Park the machine on level ground.
- When parking on slopes of less than 15%, position the machine perpendicular to the slope.
- The slope must not exceed 15%.
- Press and hold the brake pedal.
- Set the forward/reverse selector to neutral.
- Activate the parking brake.
- Release the brake pedal.
- The machine must be stationary before leaving the driver's cab.
- Fully retract the telescopic arm.
- Lower the forks or attachment to rest on the ground.
- When using an attachment with a grab or jaws, or a bucket with hydraulic opening, close the attachment fully.
- Before stopping the machine after intensive work, leave the engine idling for a few moments to allow the coolant and oil to lower the temperature of the engine and transmission. Do not forget this precaution, in the event of frequent stops or warm stalling of the engine, or else the temperature of certain parts will rise significantly due to the stopping of the cooling system, with the risk of badly damaging such parts.
- Stop the engine with the ignition switch and remove the key.
- Lock all the openings to the machine (doors, windows, cowls, etc.).
- Turn the battery cut-off to the "OFF" position in accordance with the recommendations (↩ 2 - DESCRIPTION).

H - DRIVING THE MACHINE ON THE PUBLIC HIGHWAY

(or see current legislation in other countries)

FRENCH ROAD TRAFFIC RULES

- The driving of non-type-approved "Tractor" machines on the public highway is subject to the provisions of the French Highway Code relating to special machines, defined in Article R.311-1 of the French Highway Code, in category B of the Equipment Order of November 20, 1969, which determines the procedures applicable to special machines. The machine must be fitted with an operating license plate.
- The driving of type-approved "Tractor" machines on the public highway is subject to the provisions of the French Highway Code relating to agricultural tractors, defined in Article R.311-1 of the French Highway Code. The machine must be licensed.
- The machine must be driven on the public highway in accordance with the instructions given in the manual supplied with the machine (Gross weight, Gross combination weight, towing load, axle loads, maximum speeds, etc. according to the type/version). The operator must be in possession of the machine's registration document.
- The operator must hold an HGV license, unless granted an exemption.
- When towing a trailer or agricultural equipment, the travel speed of the machine is limited to 25 km/h. In this case, a "25" disc must be affixed to the rear of the convoy.

GERMAN ROAD TRAFFIC RULES

⚠ IMPORTANT ⚠

For machines with the "Allgemeine Betriebserlaubnis" (general operating permit or ABE, in accordance with Article 20 of the StVZO "Straßenverkehrs-Zulassungsordnung"), follow the instructions below:

- Disconnect the reversing sound alarm before using a machine with a general operating permit (ABE) on the public highway.

⚠ IMPORTANT ⚠

Always reconnect the sound alarm before handling on private roads.

- Before you use the machine for handling operations on private roads:
 - Make sure that the machine's reversing sound alarm is connected and working properly.
 - Perform a functional test by putting the machine into reverse gear.
 - The audible alarm sounds.
 - Do not use the machine if the audible alarm is not working. Check the audible alarm's connection and repeat the test. Consult your dealer if the problem persists.

SAFETY INSTRUCTIONS

- Operators driving on the public highway must comply with current highway code legislation.
- The machine must comply with current road legislation. If necessary, there are optional solutions. Contact your dealer.

INSTRUCTIONS

- Make sure the revolving light is in place, switch it on and verify its operation.
- Make sure the lights, turn signals and windshield wipers are working properly.
- Check the cleanliness of the machine's mudguards.
- Check the general cleanliness of the machine before driving on public roads.
- Switch off the worklights if the machine is fitted with them.
- Select the steering mode "HIGHWAY TRAFFIC" (← 2 - DESCRIPTION: INSTRUMENTS AND CONTROLS) (depending on machine model).
- Fully retract the telescopic arm and set the attachment approximately 300 mm off the ground.
- Put the frame leveling in the central position, i.e., the transverse axis of the axles parallel to the frame (depending on the machine model).
- Fully raise the stabilizers and turn the shoes inwards (depending on the machine model).

⚠ IMPORTANT ⚠

Never coast in neutral (forward/reverse selector or gear lever in neutral or transmission cut-off button pressed) to preserve the machine's engine brake. Failure to observe this instruction on a slope will lead to excessive speed, which may make the machine uncontrollable (steering, brakes) and cause serious mechanical damage.

DRIVING THE MACHINE WITH A FRONT-MOUNTED ATTACHMENT

- You must comply with current regulations in your country, covering the possibility of driving on the public highway with a front-mounted attachment on your machine.
- If road legislation in your country authorizes circulation with a front-mounted attachment, you must at least:
 - Protect and report any sharp and/or dangerous edges on the attachment (↖ 4 - ADAPTABLE ATTACHMENTS AVAILABLE ON THE RANGE).
 - The attachment must not be loaded.
 - Make sure that the attachment does not mask the lighting range of the forward lights.
 - Make sure that current legislation in your country does not require other obligations.

OPERATING THE MACHINE WITH A TRAILER

- For using a trailer, observe the regulations in force in your country (maximum travel speed, braking, maximum weight of trailer, etc.).
- Do not forget to connect the trailer's electrical equipment to that of the machine.
- The trailer's braking system must comply with current legislation.
- If pulling a trailer with assisted braking, the tractor machine must be equipped with a trailer braking mechanism. In this case, do not forget to connect the trailer braking equipment to that of the machine.
- The vertical force on the towing hook must not exceed the maximum authorized by the manufacturer (consult the manufacturer's plate on your machine).
- The authorized gross vehicle weight must not exceed the maximum weight authorized by the manufacturer (↖ 2 - DESCRIPTION: SPECIFICATIONS).

IF NECESSARY, CONSULT YOUR DEALER.

INSTRUCTIONS FOR HANDLING A LOAD

A - CHOICE OF ATTACHMENTS

- Only attachments approved and authorized by MANITOU can be used on its machines.
- Make sure the attachment is suitable for the work to be done (◀ 4 - ADAPTABLE ATTACHMENTS AS OPTIONS ON THE RANGE).
- If the machine is equipped with the single sideshift attachment OPTION (TSDL), use only the authorized attachments (◀ 4 - ADAPTABLE ATTACHMENTS AS OPTIONS ON THE RANGE).
- Make sure the attachment is correctly installed and locked onto the machine carriage.
- Make sure that your machine attachments are working properly.
- Comply with the load chart limits for the machine for the attachment used.
- Do not exceed the rated capacity of the attachment.
- Never lift a slung load without the attachment provided for the purpose, as there is a risk of the sling slipping (◀ INSTRUCTIONS FOR HANDLING A LOAD: H - PICKING UP AND PUTTING DOWN A SUSPENDED LOAD).
- Do not handle loads suspended by straps directly on the forks (e.g. big bags), as there is a risk of shearing on sharp edges. Use an attachment designed for this purpose.

B - WEIGHT OF LOAD AND CENTER OF GRAVITY

- Before picking up a load, you must know its weight and its center of gravity.
- The longitudinal position of the center of gravity in relation to the heel of the forks (Fig. B1) is defined on the load chart for your machine (◀ 2 - DESCRIPTION: DIMENSIONS AND LOAD CHARTS). For loads with center of gravity exceeding this distance, contact your dealer.
- For irregular loads, determine the transverse center of gravity before any handling (fig. B2) and set it in the longitudinal axis of the machine.

⚠ IMPORTANT ⚠

*It is forbidden to handle a load heavier than the effective capacity defined on the machine load chart.
For loads with a moving center of gravity (e.g. liquids), take account of the variations in the center of gravity in order to determine the load to be handled and be extra vigilant and careful to limit these variations as far as possible.*

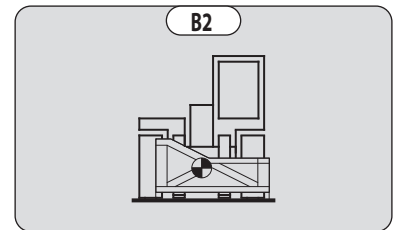
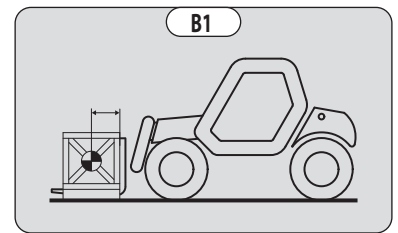

C - LONGITUDINAL STABILITY LIMITER AND WARNING DEVICE

This device gives an indication of the longitudinal stability of the machine, and limits hydraulic movements in order to ensure this stability, at least under the following operating conditions:

- when the machine is at a standstill,
 - when the machine is on firm, stable and consolidated ground,
 - when the machine is performing handling and placing operations.
- Move the boom very carefully when approaching the authorized load limit (◀ 2 - DESCRIPTION: INSTRUMENTS AND CONTROLS).
 - Always watch this device during handling operations.
 - If the "AGGRAVATING" hydraulic movements are cut off, perform only de-aggravating hydraulic movements in the following order (Fig. C): if necessary, raise the boom (1), retract the boom as far as possible (2) and lower the boom (3) to put down the load.

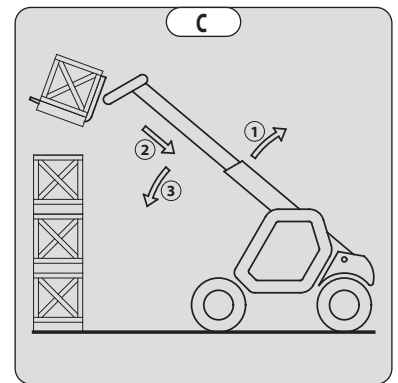

⚠ IMPORTANT ⚠

*The instrument reading may be erroneous when the steering is at full lock or the rear axle is oscillated to its maximum extent.
Before lifting a load, ensure that the machine is not in any of these situations.*

D - TRANSVERSE ATTITUDE OF THE MACHINE

Depending on machine model

The transverse attitude is the transverse slope of the frame with respect to the horizontal. Raising the boom reduces the machine's lateral stability. The machine's transverse attitude must be set with the boom in the down position as follows:

1 - MACHINE WITHOUT FRAME LEVELING USED ON TIRES

- Position the machine so that the bubble in the level is between the two lines (↩ 2 - DESCRIPTION: INSTRUMENTS AND CONTROLS).

2 - MACHINE WITH FRAME LEVELING USED ON TIRES

- Correct the tilt using the hydraulic control and check the horizontality with the spirit level. The bubble of the level must be between the two lines (↩ 2 - DESCRIPTION: INSTRUMENTS AND CONTROLS).

3 - MACHINE USED ON STABILIZERS

- Set the two stabilizers on the ground and raise the two front wheels of the machine (fig. D1).
- Correct the tilt using the stabilizers (Fig. D2) and check the horizontality with the spirit level. The bubble of the level must be between the two lines (↩ 2 - DESCRIPTION: INSTRUMENTS AND CONTROLS). In this position, the two front wheels must be off the ground.

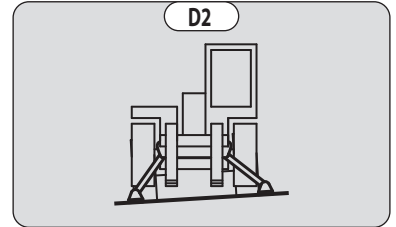
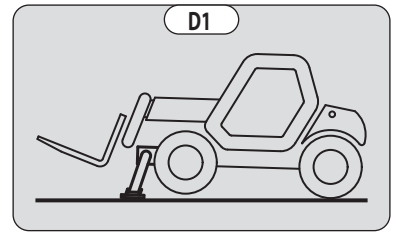

E - PICKING UP A LOAD ON THE GROUND

- Approach the machine perpendicular to the load, with the boom retracted and the forks in a horizontal position (fig. E1).
- Adjust the fork spacing and centering relative to the load to ensure stability (Fig. E2) (optional solutions exist, consult your dealer).
- Never lift a load with a single fork.

⚠ IMPORTANT ⚠

Beware of the risks of trapping or squashing limbs when manually adjusting the forks.

- Move the machine forward slowly (1) and bring the forks up to the stop in front of the load (Fig. E3). If necessary, slightly lift the boom (2) while picking up the load.
- Bring the load into the transport position.
- Tilt the load far enough backward to ensure stability (loss of load on braking or going downhill).

FOR A NON-PALLETIZED LOAD

- Tilt the carriage (1) forwards and move the machine slowly forwards (2), to insert the fork under the load (Fig. E4) (chock the load if necessary).
- Continue to move the machine (2) forward, tilting the carriage (3) (fig. E4) backward to position the load on the forks and check the load's longitudinal and lateral stability.

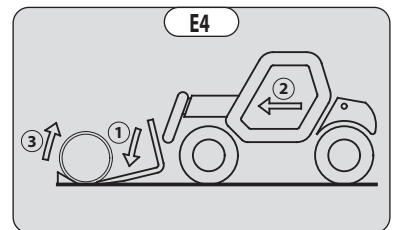
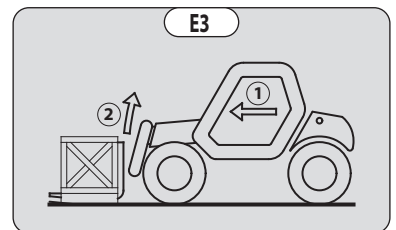
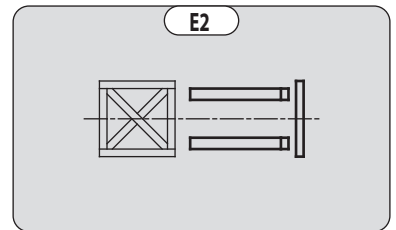
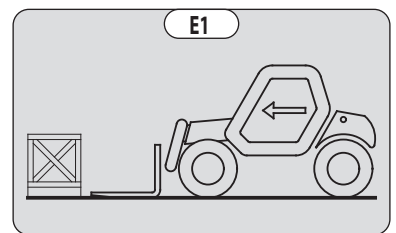

F - PICKING UP AND PUTTING DOWN A HIGH LOAD ON TIRES

⚠ IMPORTANT ⚠

You must not raise the boom if you have not checked the transverse attitude of the machine (← INSTRUCTIONS FOR HANDLING A LOAD D - TRANSVERSE ATTITUDE OF THE MACHINE).

REMINDER: Make sure that the following operations can be performed with good visibility (← OPERATING INSTRUCTIONS UNLADEN AND LADEN: D - VISIBILITY).

PICKING UP A HIGH LOAD ON TIRES

- Ensure that the forks will easily pass under the load.
- Raise and extend the boom (1) (2) until the forks are at the level of the load. If necessary, move the machine (3) forward (fig. F1), driving very slowly and carefully.
- Always remember to keep the distance necessary for inserting the forks under the load, between the stack and the machine (fig. F1) and use the shortest possible length of boom.
- Insert the forks under the load as far as they will go by alternately extending and lowering the boom (1) or, if necessary, moving the machine forward (2) (fig. F2). Activate the parking brake and place the forward/reverse selector in neutral.
- Lift the load slightly (1) and tilt the carriage (2) backwards to stabilize the load (Fig. F3).
- Tilt the load sufficiently backward to ensure its stability.
- Monitor the longitudinal stability limiter and warning device (← INSTRUCTIONS FOR HANDLING A LOAD: C - LONGITUDINAL STABILITY LIMITER AND WARNING DEVICE). If it is overloaded, set the load back down in the place from which it was picked up.
- If possible, lower the load without moving the machine. Raise the boom (1) to release the load, retract (2) and lower the jib (3) to set the load into transport position (fig. F4).
- If this is not possible, reverse the machine (1), maneuvering very gently and carefully to release the load. Retract (2) and lower the boom (3) to bring the load into the transport position (fig. F5).

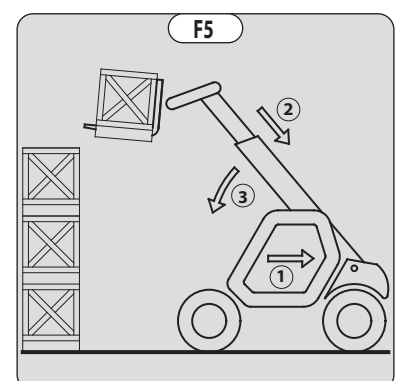
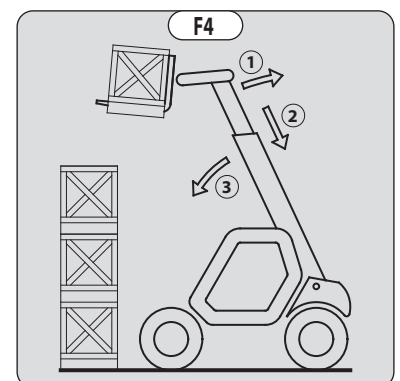
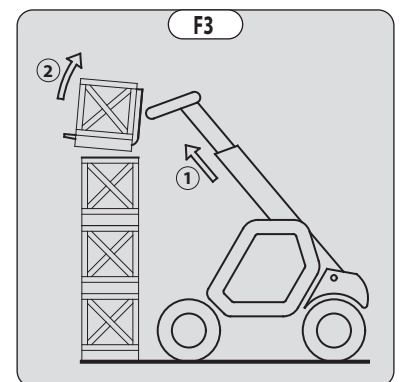
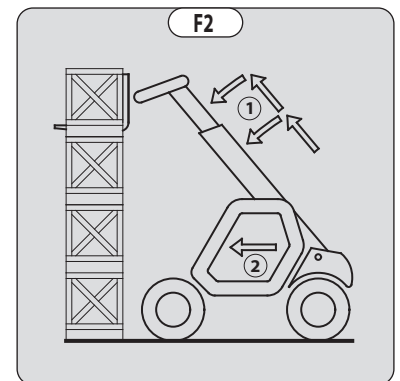
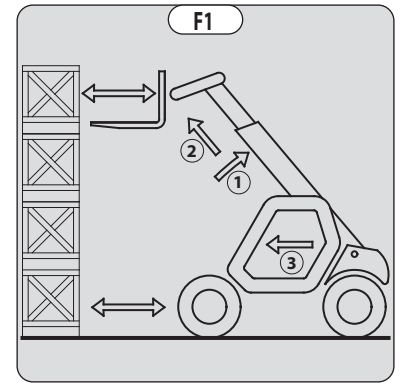

PUTTING DOWN A HIGH LOAD ON TIRES

- Approach the load in the transport position in front of the stack (Fig. F6).
- Activate the parking brake and place the forward/reverse selector in neutral.
- Raise and extend the boom (1) (2) until the load is above the stack, while monitoring the longitudinal stability limiter and warning device (☞ INSTRUCTIONS FOR HANDLING A LOAD: C - LONGITUDINAL STABILITY LIMITER AND WARNING DEVICE). If necessary, move the machine (3) forward (fig. F7), driving very slowly and carefully.
- Place the load in a horizontal position and put it down on the pile by lowering and retracting the boom (1) (2) in order to position the load correctly (Fig. F8).
- If possible, release the forks by alternately retracting and raising the boom (1) (Fig. F9). Then set the forks into transport position.
- If this is not possible, reverse the machine (1), maneuvering very slowly and carefully to release the forks (fig. F10). Then set the forks into transport position.

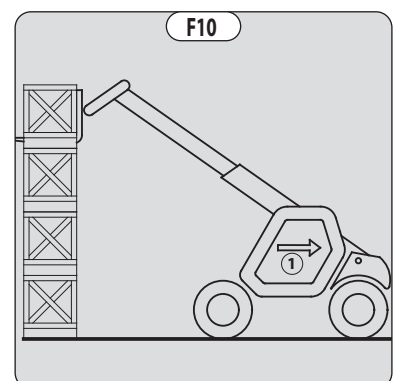
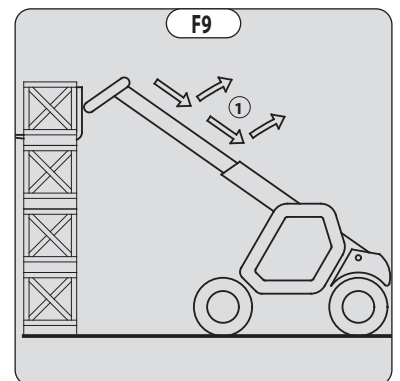
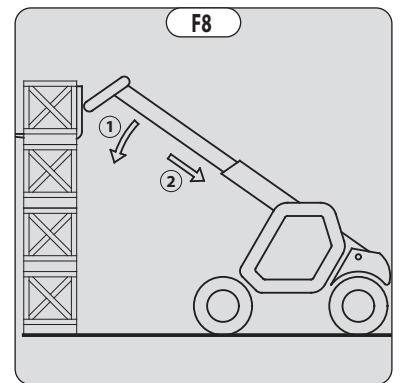
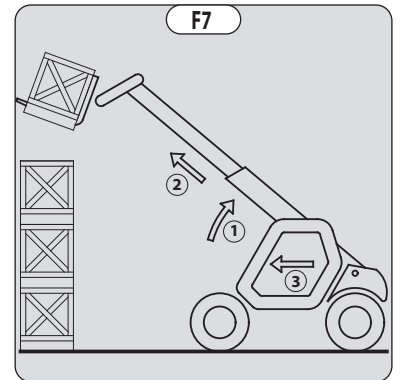
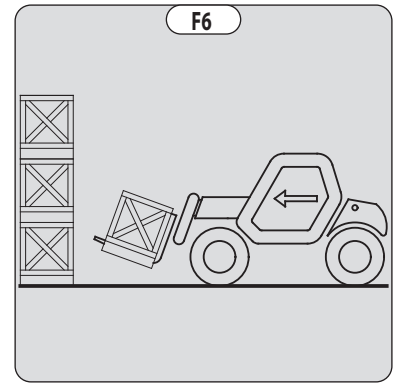

G - PICKING UP AND PUTTING DOWN A HIGH LOAD ON STABILIZERS

Depending on machine model

⚠ IMPORTANT ⚠

You must not raise the boom if you have not checked the transverse attitude of the machine (← INSTRUCTIONS FOR HANDLING A LOAD D - TRANSVERSE ATTITUDE OF THE MACHINE).

REMINDER: Make sure that the following operations can be performed with good visibility (← OPERATING INSTRUCTIONS UNLADEN AND LADEN: D - VISIBILITY).

The stabilizers are used to optimize the machine's lifting performance (← 2 - DESCRIPTION: INSTRUMENTS AND CONTROLS).

POSITIONING THE STABILIZERS WITH THE FORKS IN TRANSPORT POSITION (UNLADEN AND LADEN)

- Set the forks in transport position in front of the elevation.
- Stay far enough away to allow the boom to be raised.
- Activate the parking brake and place the forward/reverse selector in neutral.
- Set the two stabilizers on the ground and lift the two front wheels of the machine (fig. G1), while maintaining its transverse stability.

RAISING THE STABILIZERS WITH THE FORKS IN TRANSPORT POSITION (UNLADEN AND LADEN)

- Raise both stabilizers fully and at the same time.

LOWERING THE STABILIZERS WITH JIB UP (UNLADEN AND LADEN)

⚠ IMPORTANT ⚠

This operation must be exceptional and performed with great care.

- Raise the boom and retract the telescopes completely.
- Set the machine in position in front of the elevation (fig. G2), moving very slowly and carefully.
- Activate the parking brake and place the forward/reverse selector in neutral.
- Move the stabilizers very slowly and gradually as soon as they are close to the ground or in contact with it.
- Lower the two stabilizers and lift the two front wheels of the machine (fig. G3). During this operation, transverse attitude must be permanently maintained: the bubble in the level must be kept between the two lines.

SETTING THE STABILIZERS WITH THE BOOM UP (UNLADEN AND LADEN)

⚠ IMPORTANT ⚠

This operation must be exceptional and performed with great care.

- Keep the boom raised and retract the telescopes completely (Fig. G3).
- Move the stabilizers very slowly and gradually as soon as they are in contact with the ground and when they leave the ground. During this operation, transverse attitude must be permanently maintained: the bubble in the level must be kept between the two lines.
- Raise both stabilizers completely.
- Deactivate the parking brake and reverse the machine (1) very slowly and carefully to release it and lower the forks (2) into transport position (fig. G4).

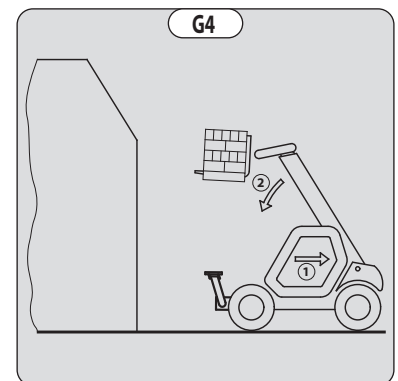
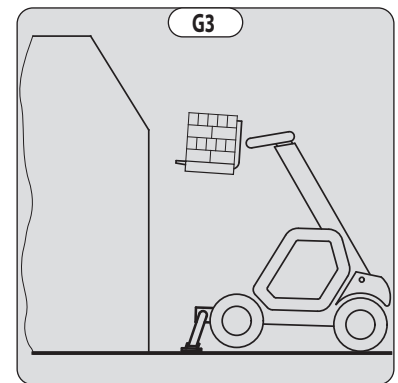
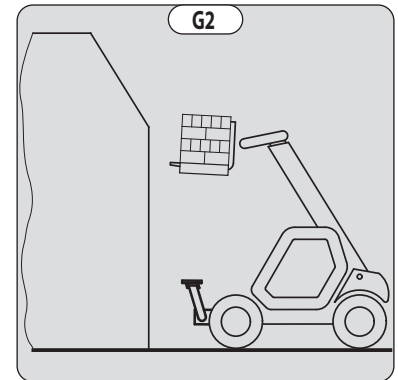
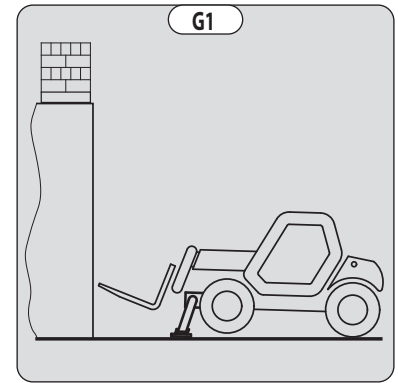

PICKING UP A HIGH LOAD ON STABILIZERS

- Ensure that the forks will easily pass under the load.
- Check the position of the machine with respect to the load and make a test run, if necessary, without picking up the load.
- Raise and extend the boom (1) (2) until the forks are at the level of the load (Fig. G5).
- Bring the forks to the stop in front of the load by alternately extending and lowering the boom (1) (Fig. G6).
- Lift the load slightly (1) and tilt the carriage (2) backwards to stabilize the load (Fig. G7).
- Monitor the longitudinal stability limiter and warning device (← INSTRUCTIONS FOR HANDLING A LOAD: C - LONGITUDINAL STABILITY LIMITER AND WARNING DEVICE). If it is overloaded, set the load back down in the place from which it was picked up.
- If possible, lower the load without moving the machine. Raise the boom (1) to release the load, retract (2) and lower the jib (3) to set the load into transport position (fig. G8).

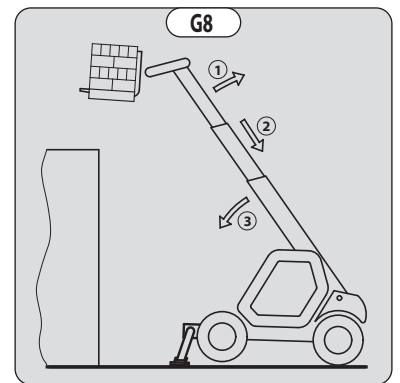
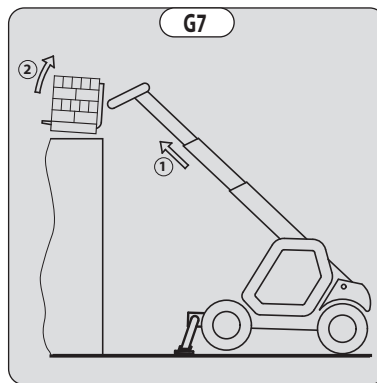
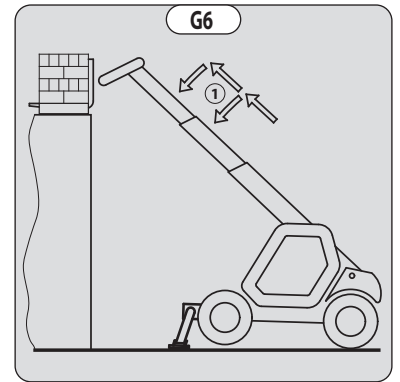
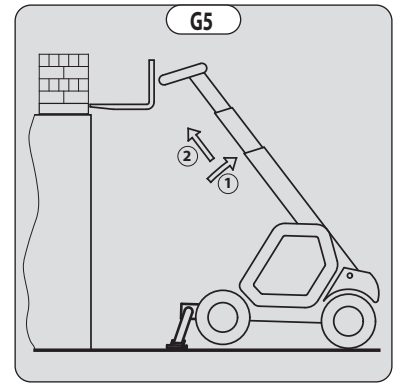

SETTING DOWN A HIGH LOAD ON STABILIZERS

- Raise and extend the boom (1) (2) until the load is above the elevation (Fig. G9), while monitoring the longitudinal stability limiter and warning device (← INSTRUCTIONS FOR HANDLING A LOAD: C - LONGITUDINAL STABILITY LIMITER AND WARNING DEVICE).
- Position the load horizontally and release it by lowering and retracting the boom (1) (2) to position the load correctly (Fig. G10).
- Free the forks by alternately retracting and raising the boom (3) (Fig. G11).
- If possible, set the boom in transport position without moving the machine.

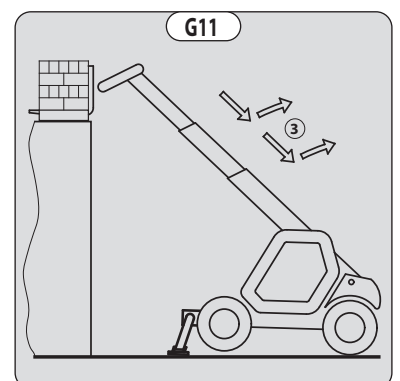
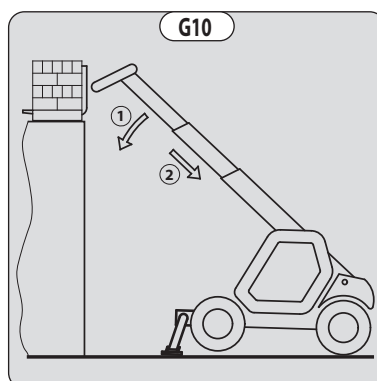
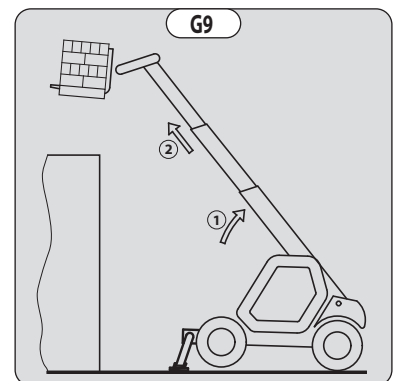

H - PICKING UP AND PUTTING DOWN A SUSPENDED LOAD

⚠ IMPORTANT ⚠

*Failure to follow the above instructions may lead the machine to lose stability and overturn.
MUST be used with a machine equipped with an operational hydraulic movement cut-off device.*

CONDITIONS OF USE

- The length of the sling or the chain shall be as short as possible to limit swinging of the load.
- Lift the load vertically along its axis, never by pulling sideways or lengthways.

HANDLING WITHOUT MOVING THE MACHINE

- Whether on stabilizers or on tires, the lateral attitude must not exceed 1% and the longitudinal attitude must not exceed 5%: the bubble of the level must be held at "0".
- Ensure that the wind speed is not higher than 10 m/s.
- Ensure that there is no one between the load and the machine.

I - TRAVELING WITH A SUSPENDED LOAD

- Before moving, inspect the terrain in order to avoid excessive slopes and cross-falls, bumps and potholes, or soft ground.
- Ensure that the wind speed is not higher than 36 km/h.
- The machine must not travel at more than 0.4 m/s (1.4 km/h, i.e. one quarter walking speed).
- Drive and stop the machine gently and smoothly to minimize swinging of the load.
- Carry the load a few centimeters above the ground (max. 30 cm) the shortest possible jib length. Do not exceed the offset indicated on the load chart. If the load begins to swing excessively, do not hesitate to stop and lower the jib to set down the load.
- Before moving the machine, check the longitudinal stability limiter and warning device (☞ 2 - DESCRIPTION: INSTRUMENTS AND CONTROLS), only the green LEDs and possible the yellow LEDs should be lit
- During transport, the lift truck operator must be assisted by a person on the ground (standing a minimum of 3 m from the load), who will limit swinging of the load using a bar or a rope. Ensure that this person is always clearly in view.
- The lateral attitude must not exceed 5%: the bubble in the level must be kept between the two "MAX" marks.
- The longitudinal attitude must not exceed 15% with the load facing uphill and 10% with the load facing downhill.
- The boom angle must not exceed 45°.
- If the first red LED of the longitudinal stability limiter and warning device (☞ 2 - DESCRIPTION: INSTRUMENTS AND CONTROLS) comes on while traveling, gently bring the machine to a halt and stabilize the load. Retract the telescope to reduce the offset of the load.

INSTRUCTIONS FOR USE AS A LOADER

For agricultural-type machines (MLT range)

A - LOADING

⚠ IMPORTANT ⚠

You must not raise the boom if you have not checked the transverse attitude of the machine (← INSTRUCTIONS FOR HANDLING A LOAD D - TRANSVERSE ATTITUDE OF THE MACHINE).

REMINDER: Make sure that the following operations can be performed with good visibility (← OPERATING INSTRUCTIONS UNLADEN AND LADEN: D - VISIBILITY).

FILLING THE BUCKET

- Place the bottom of the bucket in a horizontal position, just in contact with the ground (1) (Fig. A1).
- Move forward gradually (2) while simultaneously raising the boom and tilting the bucket backwards (3), for improved filling and breakout (Fig. A1).
- Reverse the machine (1) very carefully and gently to free the bucket. Lower the boom (2) into the transport position (Fig. A2).

⚠ IMPORTANT ⚠

Tilt the bucket sufficiently back to avoid spilling product and ensure its stability (loss of product under braking).

LOADING A TRAILER

- Approach the side of the trailer in the transport position (Fig. A3).
- Raise and extend the boom (1) (2) until the bucket is above the trailer, while monitoring the longitudinal stability limiter and warning device (← INSTRUCTIONS FOR HANDLING A LOAD: C - LONGITUDINAL STABILITY LIMITER AND WARNING DEVICE) (Fig. A4).
- Drive the machine forward (3) very carefully and gently so that the bucket empties its load in the center of the trailer (Fig. A4).
- Immobilize the machine with the brake pedal and put the reversing shift lever in neutral.

N.B.: Immobilizing the machine with the brake pedal means that the transmission should be in neutral. Failure to follow this recommendation may lead to overheating and damage to the brakes.

- Slowly discharge the product (4) (Fig. A4).
- Tilt the bucket backwards (1) and reverse the machine (2) very carefully and gently (Fig. A5).
- Retract (3) and lower the boom (4) into the transport position (Fig. A5).

B - BACKFILLING

- Place the bottom of the bucket in a horizontal position, just in contact with the ground (1) (Fig. B1).
- Drive forward gradually (2). Once filled, the bucket will act as a leveling blade (Fig. B1).

⚠ IMPORTANT ⚠

When driving, beware of trenches as well as recently excavated and/or backfilled ground.

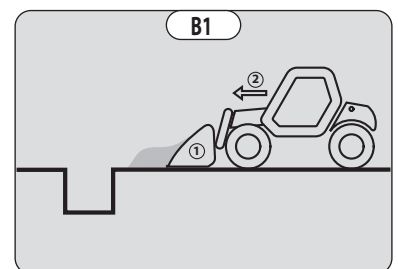
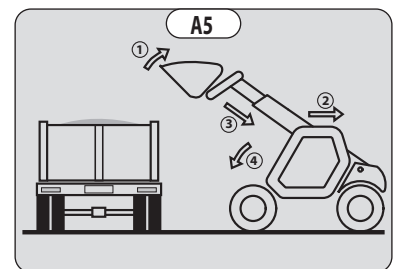
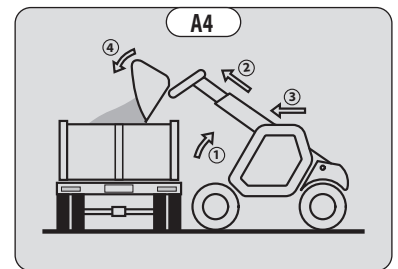
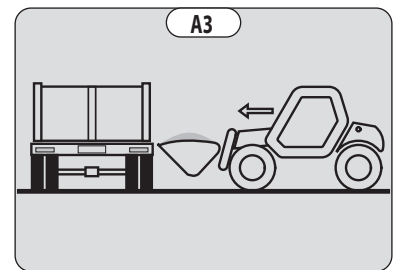
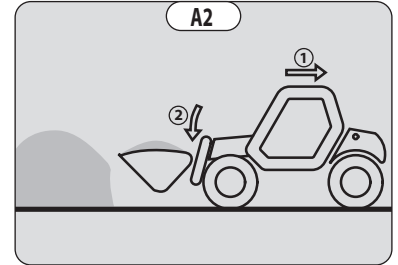
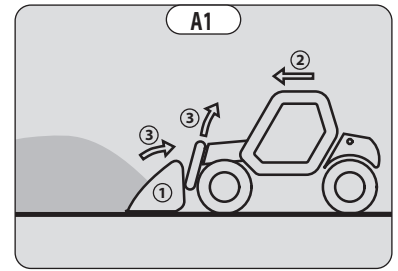

INSTRUCTIONS FOR USING THE MOBILE ELEVATING WORK PLATFORM

For machines equipped with a MOBILE ELEVATING WORK PLATFORM

A - AUTHORIZATION FOR USE

- Operation of the platform requires further authorization in addition to that of the machine.

B - SUITABILITY OF THE PLATFORM FOR THE JOB

- Our machines fitted with mobile elevating work platforms are compliant with standard **EN 280** for Europe and standard **AS/NZS 1418.10:2011** for Australia, corresponding to the classification of Group C1 to C3 in accordance with this standard.
- MANITOU has ensured that this platform is suitable for use under the normal operating conditions provided in this operator's manual, with a STATIC test coefficient of 1.25 and a DYNAMIC test coefficient of 1.1 as specified in harmonized European standard **EN 280** for mobile elevating work platforms.
- Before commissioning, the company manager must make sure that the platform is appropriate for the work to be done, and perform certain tests (in accordance with current legislation).

C - PROVIDED ON THE PLATFORM

- Wear suitable clothing when using the platform, avoid loose-fitting garments.
- Never use the platform with hands or shoes that are wet or soiled with greasy substances.
- Remain alert at all times when using the platform. Do not listen to the radio or music using headphones or earphones.
- MANITOU strongly recommends wearing a safety harness attached to an attachment point in the platform. Wearing a safety harness or other personal protection equipment against falls may be compulsory. Comply with local, government and national regulations in force, employer's safety rules and work site regulations .
- The safety harness or other personal protection equipment against falls must comply with local, government, and national regulations in force. They must be inspected in accordance with the regulations in force.
- The control units must never be used for any other than their intended purposes (e.g. Climbing onto or down from the machine, coat hanger, etc.).
- Safety helmets must be worn.
- The operator must always be in his normal position in the driver's cab: it is prohibited to have arms or legs, or generally any part of the body, outside the platform.
- Ensure that materials loaded onto the platform (pipes, cables, containers, etc.) cannot fall out. Do not pile these materials to the point where it is necessary to step over them.

D - USING THE PLATFORM

- However experienced they may be, operators must acquaint themselves with the emplacement and operation of all control instruments prior to operating the platform.
- Check before use that the platform has been correctly assembled and locked onto the machine.
- Do not enter or exit the platform unless it is fully lowered.
- Always enter and exit the platform through the gate or using the sliding intermediate cross members (depending on the model).
- Always enter and exit facing the interior of the platform.
- Always use both hands and one foot or both feet and one hand to enter and exit the platform.
- Make sure that the sliding intermediate cross members (depending on the model) are in the lower position and that the gate is properly closed (depending on the model) before using this platform.
- Do not attach the sliding mid rails in the high position.
- The platform should be operated in an area free of any obstructions or danger when it is lowered to the ground.
- The operator using the platform must be aided by someone on the ground with adequate training.
- You should stay within the limits set out in the platform load chart.
- The lateral constraints are limited (↩ 2 - DESCRIPTION: SPECIFICATIONS).
- It is strictly forbidden to suspend a load from the platform or the machine's boom without an attachment provided for the purpose (↩ INSTRUCTIONS FOR HANDLING A LOAD: H - PICKING UP AND PUTTING DOWN A SUSPENDED LOAD).
- The platform cannot be used as a crane or a lift for permanently transporting people or materials, nor as jacks or supports.
- The machine must not be moved with one (or more) person(s) on the platform.
- It is forbidden to transport people on the platform using the hydraulic controls in the machine's cab (except in case of rescue).
- The operator must not climb onto to off the platform when it is not on ground level (jib retracted and in the down position).
- The machine must not be fitted with unauthorized attachments that increase the windage of the assembly.
- Do not use ladders or improvised structures on the platform to gain extra height.
- Do not climb onto the rails of the platform to gain extra height.
- It is forbidden to use the platform on forks. The fork slots are only to, be used for storing the platform and not for lifting people under any circumstances.

E - ENVIRONMENT

- Respect a safety distance between power lines or live components and any part of the body, any conductive object or any part of the machine, unless the local, government and national applicable regulations, the safety rules of the employer or construction site regulations are more strict in terms of distance required.
- Allow for platform movement and swaying or sagging power lines.

⚠ IMPORTANT ⚠

It is forbidden to use the platform close to electricity cables. Maintain the specified safe distances.

RATED VOLTAGE (VOLTS)	SAFETY DISTANCE (METERS)
50 < U < 1000	2,30 M
1000 < U < 30000	2,50 M
30000 < U < 45000	2,60 M
45000 < U < 63000	2,80 M
63000 < U < 90000	3,00 M
90000 < U < 150000	3,40 M
150000 < U < 225000	4,00 M
225000 < U < 400000	5,30 M
400000 < U < 750000	7,90 M

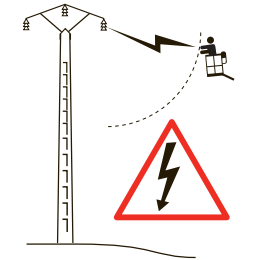

⚠ IMPORTANT ⚠

It is strictly forbidden to use the platform when the wind speed exceeds 45 km/h.

- To visually recognize this wind speed, refer to the empirical wind evaluation scale below:

BEAUFORT scale (wind speed at a height of 10 m on a flat site)						
Force	Type of wind	Speed (knots)	Speed (km/h)	Speed (m/s)	Effects on Land	Sea conditions
0	Calm	0 - 1	0 - 1	< 0.3	Smoke rises vertically.	Sea is like a mirror.
1	Light air	1 - 3	1 - 5	0.3 - 1.5	Smoke indicates direction of wind.	Ripples with appearance of scale, no foam crests.
2	Light breeze	4 - 6	6 - 11	1.6 - 3.3	Wind felt on face, leaves rustle.	Short wavelets, but pronounced.
3	Gentle breeze	7 - 10	12 - 19	3.4 - 5.4	Leaves and small twigs in constant motion.	Very small waves, crests begin to break.
4	Moderate breeze	11 - 16	20 - 28	5.5 - 7.9	Wind raises dust and loose pieces of paper; small branches are moved.	Small waves, becoming longer, numerous whitecaps.
5	Fresh breeze	17 - 21	29 - 38	8 - 10.7	Small trees in leaf begin to sway.	Wavelets form on inland waters; moderate waves, taking longer form.
6	Strong breeze	22 - 27	39 - 49	10.8 - 13.8	Large branches in motion, whistling heard in overhead wires, umbrella use becomes difficult.	Larger waves forming, whitecaps everywhere, some spray.
7	Near gale	28 - 33	50 - 61	13.9 - 17.1	Whole trees in motion, inconvenience felt when walking against the wind.	Sea heaps up; white foam from breaking waves begins to be blown in streaks along the direction of the wind.
8	Gale	34 - 40	62 - 74	17.2 - 20.7	Wind breaks twigs off trees; impedes progress.	Moderately high waves of greater length; edges of crests begin to break into spindrift.
9	Strong gale	41 - 47	75 - 88	20.8 - 24.4	Wind damages roofs (chimneys, slates, etc.).	High waves, crests of waves begin to topple, streaks of foam; reduced visibility.
10	Storm	48 - 55	89 - 102	24.5 - 28.4	Seldom experienced inland; trees uprooted; considerable structural damage occurs.	Very high waves; white streaks of foam; reduced visibility.
11	Violent storm	56 - 63	103 - 117	28.5 - 32.6	Very rare, widespread damage.	Exceptionally high waves able to hide medium sized ships from view, reduced visibility.
12	Hurricane	64 +	118 +	32.7 +	Devastating damage.	Sea completely white; air filled with foam and spray, very reduced visibility.

F - MAINTENANCE

⚠ IMPORTANT ⚠

*Your platform must be periodically inspected to ensure its continued compliance.
 The frequency of this inspection is defined by the legislation in force in the country in which the platform is used.
 In France, a general periodic inspection every 6 months (Decree of March 1, 2004).*

INSTRUCTIONS FOR USING THE RADIO-CONTROL

For machines with RC radio control

HOW TO USE THE RADIO-CONTROL

SAFETY INSTRUCTIONS

⚠ IMPORTANT ⚠

It is prohibited to lift people in the platform using the radio-control.

It is prohibited to use the radio-control from the platform:

- This radio-control consists of electronic and mechanical safety elements. It cannot receive commands from another transmitter because the internal encoding is unique to each radio-control.

⚠ IMPORTANT ⚠

If it is used improperly or incorrectly, there is a risk of danger to:

- The physical and mental health of the user or others.

- The machine and other neighboring items.

Everyone working with this radio-control:

- Must be qualified in line with current regulations and trained accordingly.

- Must follow this instruction manual as closely as possible.

- The system is used to control the machine remotely via radio waves. Commands are also transmitted if the machine is out of sight (behind an obstacle or a building for example), this is why:
 - After stopping the truck and removing the key switch (only possible when it is stationary), always place the transmitter in a safe, dry place.
 - Before performing any installation, servicing or repair work, always switch off power sources (in particular, electric welding devices and electric head units on hydraulic distributors must be disconnected at each section).
 - Never remove or alter the safety devices (such as the hand-guard frame, key, emergency stop button, etc.).

⚠ IMPORTANT ⚠

Never drive the machine if it is not continuously and perfectly within view of the operator.

- Before leaving the transmitter, the operator must make sure that it cannot be used by an unauthorized third person: either by removing the key button from the transmitter or locking it in an inaccessible place.
- The user must ensure that the instruction manual is accessible at all times and that operators have read and understood it.

INSTRUCTIONS

- Take up position in a stable place with no risk of slipping.
- Before using the transmitter, make sure there is nobody within the working area.
- Only use the transmitter with its carrying device or installed correctly on the platform.

⚠ IMPORTANT ⚠

When you remove the transmitter, remove the accumulator and key button so that it cannot be used accidentally or deliberately by anyone else.

PROTECTIVE DEVICES

- The machine will be immobilized within a maximum of 450 milliseconds (approx. 0.5 second):
 - If the emergency stop button of the transmitter is pressed (50 milliseconds), or that of the machine.
 - If the transmission distance of the radio waves is exceeded.
 - If the transmitter is faulty.
 - If an interfering radio signal is received from elsewhere.
 - If the accumulator is removed from its housing in the transmitter.
 - If the battery reaches the end of its autonomy.
 - If the transmitter is switched off by turning the key switch to the off position.
- These protective devices are provided for the safety of personnel and property and must never be modified, removed or bypassed in any way whatsoever!
- The hand-guard frame prevents external action on a joystick (e.g. if the transmitter is dropped, or if the operator leans on a guard-rail).
- An electronic safety device prevents radio transmission from being initiated if the joysticks are not mechanically and electrically at rest and if the internal combustion engine speed selector is not set to idle.

⚠ IMPORTANT ⚠

In an emergency, press the transmitter emergency stop button immediately; then follow the manual's instructions (↩ 2 - DESCRIPTION: INSTRUMENTS AND CONTROLS).

MACHINE MAINTENANCE INSTRUCTIONS

GENERAL INSTRUCTIONS

⚠ IMPORTANT ⚠

Carefully read and understand this operator's manual before any operation on this machine.

Carry out all repairs immediately, even if the repairs concerned are minor.

Repair all leaks immediately, even if the leak concerned is minor.

Be careful of the risk of burns and splashing (exhaust, radiator, engine, hydraulic oil, etc.).

- Make sure the area is adequately ventilated before starting up the machine.
- Wear clothes suitable for the maintenance of the machine. Avoid wearing jewelry and loose clothes. Tie back and protect your hair, if necessary.
- Stop the engine and remove the ignition key before carrying out any work.

PLACING THE JIB SAFETY WEDGE

- The machine is equipped with a boom safety wedge (↔ 2 - DESCRIPTION: INSTRUMENTS AND CONTROLS) that must be installed on the lifting cylinder rod when working beneath the boom.

ACCORDING TO INSTALLATION

FITTING THE WEDGE

- Fully raise the jib.
- Place the safety wedge 1 on the rod of the lifting cylinder and secure with the rod 2 and the pin 3.
- Slowly lower the jib then stop the hydraulic movements before it comes into contact with the wedge.

REMOVING THE WEDGE

- Fully raise the jib.
- Remove the pin and the rod.
- Return the safety wedge to the storage location provided on the machine.

⚠ IMPORTANT ⚠

Only use the wedge supplied with the machine.

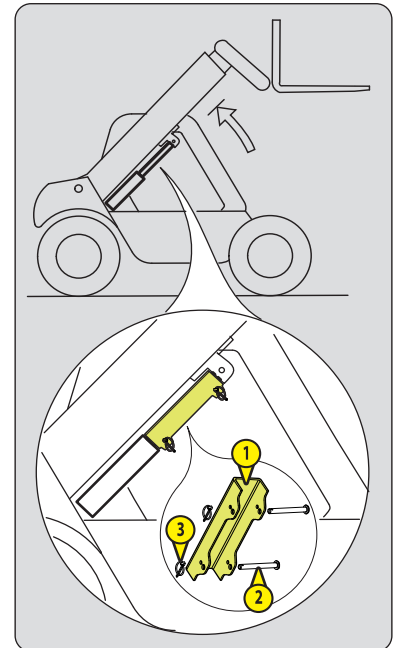

ACCORDING TO INSTALLATION

FITTING THE WEDGE

- Fully raise the jib.
- Loosen the thumbwheels 1.
- Assemble the parts of the safety wedge 2 around the cylinder rod and lock with the pins 3.

NOTE: the stop flats 4 of the safety wedge must be located towards the bottom of the lifting cylinder 5.

- Slowly lower the jib then stop the hydraulic movements before it comes into contact with the wedge.

REMOVING THE WEDGE

- Fully raise the jib.
- Remove the pins 3.
- Put the parts of the safety wedge 2 back on the machine and lock them with the thumbwheels 1.
- Replace the pins 3 on the parts of the safety wedge.

⚠ IMPORTANT ⚠

Only use the wedge supplied with the machine.

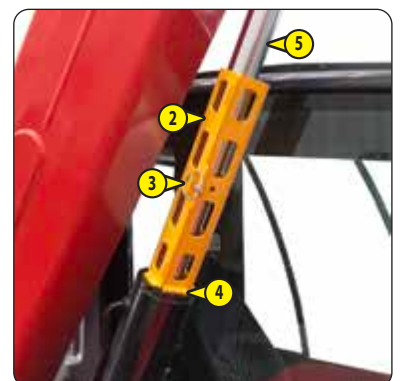
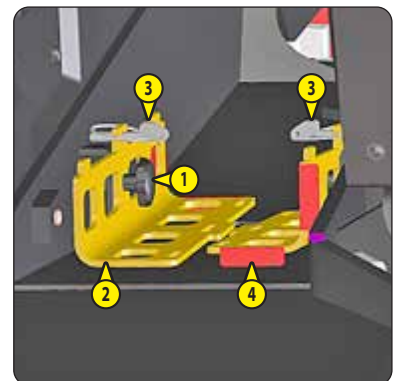

MAINTENANCE

- Perform the periodic service (↩ 3 - MAINTENANCE) to keep your machine in good working order. Failure to perform periodic maintenance may invalidate the contractual warranty.

MAINTENANCE LOGBOOK

- The maintenance operations carried out in accordance with the recommendations given in section 3 - MAINTENANCE and the other inspection, servicing or repair operations or modifications performed on the machine shall be recorded in a maintenance logbook.
- The entry for each operation should include the date of the work, the names of the individuals or companies having performed them, the type of operation and its frequency, if applicable.
- If machine elements are replaced, the part numbers of these elements shall be indicated.

LUBRICANT AND FUEL LEVELS

- Use the recommended lubricants (never use contaminated lubricants).
- Do not fill the fuel tank when the engine is running.
- Only fill up the fuel tank in areas specified for this purpose.
- Do not fill the fuel tank to the maximum level.
- Do not smoke or approach the machine with a flame when the fuel tank is open or is being filled.

HYDRAULICS

- Any work on the load handling hydraulic circuit is forbidden except for the operations described in chapter: 3 - MAINTENANCE.
- Do not attempt to loosen unions, hoses or any hydraulic component with the circuit under pressure.

⚠ IMPORTANT ⚠

COUNTERBALANCE VALVE: it is dangerous to change the setting or remove the counterbalance valves or safety valves which may be fitted to the cylinders of your machine.
HYDRAULIC ACCUMULATOR: dismantling hydraulic accumulators and their pipes which may be fitted on your machine is dangerous. Such operations must only be performed by approved personnel (consult your dealer).

ELECTRICITY

- Do not short-circuit the starter relay to start the engine. If the forward/reverse selector is not in neutral and the parking brake is not on, the machine may suddenly start to move.
- Do not place metal items on the battery.
- Disconnect the battery before working on the electrical circuit.

WELDING ON THE MACHINE

⚠ IMPORTANT ⚠

Welding operations on the machine for the purposes of maintenance or repairs must only be carried out by people authorized by MANITOU.

- Disconnect the battery before any welding operations on the machine.
- When carrying out electric welding work on the machine, connect the negative cable from the equipment directly to the part being welded so as to avoid very high current passing through the alternator.
- Never carry out welding or work which gives off heat on an assembled tire. The heat would increase the pressure which could cause the tire to explode.
- If the machine is equipped with an electronic control unit, disconnect it before starting to weld so as to avoid the risk of causing irreparable damage to electronic components.

WASHING THE MACHINE

⚠ IMPORTANT ⚠

When washing with a high pressure cleaner, avoid the engine air intakes, the cylinder rod wiper seals, the hinges, the structural components and the electrical connections, etc.

- Clean the machine or at least the area concerned before any intervention.
- Remember to close and lock all openings on the machine (doors, windows, cowls, etc.).
- If necessary, protect against penetration of water, steam or cleaning agents, components susceptible of being damaged, particularly electrical components and connections and the injection pump.
- Clean the machine of any traces of fuel, oil or grease.

TRANSPORTING THE MACHINE

⚠ IMPORTANT ⚠

Transporting the machine involves real risks for the operator and others involved.

- Towing, winching, slinging or transporting the machine (⚠ 3 - MAINTENANCE).

PROLONGED MACHINE SHUTDOWN

INTRODUCTION

⚠ IMPORTANT ⚠

Procedures to follow for long duration standstill and for bringing back the machine into service must be performed by your dealership.

This period of long duration standstill must not exceed 12 months.

After 12 months, repeat the procedures for putting the machine back into service and long-term shutdown.

The recommendations below are intended to prevent the machine from being damaged when it is not used for a period of more than 3 months.

PREPARATION OF THE MACHINE

- Clean the machine thoroughly.
- Check and repair any fuel, oil, water or air leaks.
- Replace or repair any worn or damaged parts.
- Wash the painted surfaces of the machine in clear and cold water and wipe them.
- Touch up the paintwork if necessary.
- Lower the lifting structure fully.
- Retract the telescopic arms.
- Release the pressure in the hydraulic circuits.
- Shut down the machine.

DEF (Diesel Exhaust Fluid) TANK

Depending on machine model

- Drain down and rinse the DEF (Diesel Exhaust Fluid) tank.
- Replace the "DEF" (Diesel Exhaust Fluid) feed pump filter (⚠ 3 - MAINTENANCE).
- Slowly fill the tank with new DEF up to the bottom of the filler neck.
- Start up the machine to pressurize the circuit and bring it up to working temperature, then shut down the engine.
- If necessary, top up the tank.

PROTECTING THE ENGINE

- Contact your dealer to obtain the procedure for protecting the inside of the engine (use of protection product).
- Fill the tank with fuel (↩ 3 - MAINTENANCE).
- Replace the engine oil and oil filter (↩ 3 - MAINTENANCE).
- Replace the coolant (↩ 3 - MAINTENANCE).
- Leave the engine running at idling speed for a few minutes, then switch off.
- Run the engine for a short time so that the oil and cooling liquid circulate inside.
- Disconnect the battery and store it in a safe place away from the cold, after charging it to maximum capacity.
- Block the outlet with waterproof adhesive tape.
- Remove the drive belts and store them in a safe place.
- Disconnect the engine cut-off solenoid on the injection pump and carefully insulate the connection.

MACHINE PROTECTION

Place the machine on level ground.

- Set the machine on axle stands so that the tires are off the ground.
- Deactivate the parking brake (depending on machine model).
- Protect cylinder rods which will not be retracted from corrosion.
- Wrap the wheels.

N.B.: If the machine is to be stored outdoors, cover it with a waterproof tarpaulin.

RETURNING THE MACHINE TO SERVICE



Make sure the area is adequately ventilated before starting up the machine.

- Remove the waterproof adhesive tape from all the orifices.
- Remove the protection from the cylinder rods and wheels.
- Refit and reconnect the battery.
- Activate the parking brake and remove the axle stands.
- Perform the daily maintenance operations (↩ 3 - MAINTENANCE).
- Perform the weekly maintenance operations (↩ 3 - MAINTENANCE).
- Drain and clean the fuel tank (↩ 3 - MAINTENANCE).
- Fill the fuel tank with clean diesel filtered through the filler port.
- Replace the fuel filter (↩ 3 - MAINTENANCE).
- Replace the fuel pre-filter (↩ 3 - MAINTENANCE) (depending on the model of machine).
- Drain and rinse the DEF tank (depending on the machine model).
- Top up, slowly fill the tank with new "DEF" (Diesel Exhaust Fluid) up to the bottom of the filler neck (depending on the machine model).
- Refit and set the tension in the belts. (↩ 3 - MAINTENANCE).
- Turn the engine over with the starter, to allow the oil pressure to rise.
- Reconnect the engine cut-off solenoid.
- Lubricate the machine completely (↩ 3 - MAINTENANCE).
- Start up the machine, following the operating and safety instructions (↩ OPERATING INSTRUCTIONS UNLADEN AND LADEN).
- Perform all the lifting structure's hydraulic movements up to the end position for each cylinder.

DISPOSING OF THE MACHINE

⚠ IMPORTANT ⚠

Consult your dealer before disposing of the machine.

RECYCLING OF MATERIALS

METALS

- Metals are 100% recoverable and recyclable.

PLASTICS

- Plastic parts are identified with a marking in accordance with current regulations.
- A limited range of materials is used to simplify the recycling process.
- The majority of the plastic components are made of "thermoplastic" plastics, which are easily recycled by melting, granulating or grinding.

RUBBER

- Tires and seals can be ground for use in cement manufacture or to obtain reusable granules.

GLASS

- Glass items can be removed and collected for processing by glaziers.

ENVIRONMENTAL PROTECTION

By entrusting the maintenance of your machine to the MANITOU network, the risk of pollution is limited and the contribution to environmental protection is made.

WORN OR DAMAGED PARTS

- Do not dump them in the countryside.
- MANITOU and its network have signed-up to a scheme of environmental protection through recycling.

USED OIL

- The MANITOU network organizes the collection and processing of used oil.
- By handing over your waste oil to MANITOU, the risk of pollution is limited.

USED BATTERIES

- Do not throw away batteries, as they contain metals that are harmful for the environment.
- Return them to the MANITOU network or any other approved collection point.

N.B.: MANITOU aims to manufacture machines that provide the best performance and limit polluting emissions.

2 - DESCRIPTION

2 - DESCRIPTION

"CE" DECLARATION OF CONFORMITY	2-4
UKCA DECLARATION OF CONFORMITY	2-6
SAFETY PLATES AND STICKERS	2-8
IDENTIFICATION OF THE LIFT TRUCK	2-12
SPECIFICATIONS MT 730 H 75K ST5 S1	2-14
SPECIFICATIONS MT 930 H 75K ST5 S1	2-16
TIRES MT 730 H 75K ST5 S1	2-18
TIRES MT 930 H 75K ST5 S1	2-20
DIMENSIONS MT 730 H 75K ST5 S1	2-22
LOAD CHARTS MT 730 H 75K ST5 S1	2-24
DIMENSIONS MT 930 H 75K ST5 S1	2-26
LOAD CHARTS MT 930 H 75K ST5 S1	2-28
VISIBILITY MT 730 H 75K ST5 S1	2-30
VISIBILITY MT 930 H 75K ST5 S1	2-32
INSTRUMENTS AND CONTROLS	2-34
EMERGENCY BRAKE	2-36
EMERGENCY EXIT	2-37
TOWING DEVICE	2-60
DESCRIPTION AND USE OF THE OPTIONS	2-62

"CE" DECLARATION OF CONFORMITY

This document is a specimen of the CE Declaration of Conformity and includes the contents of the original declaration supplied with the machine.

This specimen and the original document may contain fields that are not applicable to your machine. These fields are left blank if not applicable.

Refer to the original Declaration of Conformity for all data applicable to your machine.

1) **DÉCLARATION «CE» DE CONFORMITÉ (originale)** **«EC» DECLARATION OF CONFORMITY (original)**

2) Constructeur, *Manufacturer* : **MANITOU BF**

3) Adresse, *Address* : **430, RUE DE L'AUBINIÈRE - B.P 10249
44158 - ANCENIS - CEDEX - FRANCE**

4) Titulaire du dossier technique, *Holder of the technical file* : **MANITOU BF**

3) Adresse, *Address* : **430, RUE DE L'AUBINIÈRE - B.P 10249
44158 - ANCENIS - CEDEX - FRANCE**

5) Le constructeur déclare que la machine décrite ci-après, *The manufacturer declares that the machine described below* :

Rough-terrain variable-reach truck

MT 730 H 75K ST5 S1

MT 930 H 75K ST5 S1

6) Est conforme aux directives suivantes et à leurs transpositions en droit national (si applicables),
Complies with the following directives and their transpositions into national law (if applicable) :

2006/42/CE

7) Pour les machines annexe IV, *For annex IV machines* : Non applicable

8) Numéro d'attestation, *Certificate number* : Non applicable

9) Organisme notifié, *Notified body* : Non applicable

2000/14/CE + 2005/88/CE

10) Procédure appliquée, *Applied procedure* : ANNEXE VIII

9) Organisme notifié, *Notified body* : **SNCH
11 ROUTE DU LUXEMBOURG
5201 SANDWEILER - LUXEMBOURG**

11) Niveau de puissance acoustique, *Sound power level* :

12) Mesuré, *Measured* : dB (A)

13) Garanti, *Guaranteed* : dB (A)

2014/30/UE

14) Normes harmonisées utilisées, *Harmonised standards used* :

EN1459 ; EN 12895

15) Normes ou dispositions techniques utilisées, *Standards or technical provisions used* :

16) Fait à, *Done at* :

17) Date, *Date* :

18) Nom du signataire, *Name of signatory* :

19) Fonction, *Function* :

20) Société, *Company* :

21) Signature, *Signature* :

bg : 1) удостоверение за « CE » съответствие (оригинална), 2) Фирмата, 3) Адрес, 4) Техническо досие, 5) Фабрикант на описаната по-долу машина, 6) Обявява, че тази машина, 7) товара на следните директиви и на тяхното съответствие национално право, 8) За машините към допълнение IV, 9) Номер на удостоверението, 10) Наименувана фирма, 15) хармонизирани стандарти използвани, 16) стандарти или технически правила, използвани, 17) Изработено в, 18) Дата, 19) Име на разписалия се, 20) Функция, 21) Функция.

cs : 1) ES prohlášení o shodě (původní), 2) Název společnosti, 3) Adresa, 4) Technická dokumentace, 5) Výrobce níže uvedeného stroje, 6) Prohlašuje, že tento stroj, 7) Je v souladu s následujícími směrnicemi a směrnicemi transponovanými do vnitrostátního práva, 8) Pro stroje v příloze IV, 9) Číslo certifikátu, 10) Notifikační orgán, 15) harmonizované normy použité, 16) Normy a technických pravidel používaných, 17) Místo vydání, 18) Datum vydání, 19) Jméno podepsaného, 20) Funkce, 21) Podpis.

da : 1) EF Overensstemmelseserklæring (original), 2) Firmaet, 3) Adresse, 4) tekniske dossier, 5) Konstruktor af nedenfor beskrevne maskine, 6) Erklærer, at denne maskine, 7) Overholder nedennævnte direktiver og disses gennemførelse til national ret, 8) For maskiner under bilag IV, 9) Certifikat nummer, 10) Bemyndigede organ, 15) harmoniserede standarder, der anvendes, 16) standarder eller tekniske regler, 17) Udfærdiget i, 18) Dato, 19) Underskrivers navn, 20) Funktion, 21) Underskrift.

de : 1) EG-Konformitätserklärung (original), 2) Die Firma, 3) Adresse, 4) Technischen Unterlagen, 5) Hersteller der nachfolgend beschriebenen Maschine, 6) Erklärt, dass diese Maschine, 7) den folgenden Richtlinien und deren Umsetzung in die nationale Gesetzgebung entspricht, 8) Für die Maschinen laut Anhang IV, 9) Bescheinigungsnummer, 10) Benannte Stelle, 15) angewandten harmonisierten Normen, 16) angewandten sonstigen technischen Normen und Spezifikationen, 17) Ausgestellt in, 18) Datum, 19) Name des Unterzeichners, 20) Funktion, 21) Unterschrift.

el : 1) Δήλωση συμμόρφωσης CE (πρωτότυπο), 2) Η εταιρεία, 3) Διεύθυνση, 4) τεχνικό φάκελο, 5) Κατασκευάστρια του εξής περιγραφόμενου μηχανήματος, 6) Δηλώνει ότι αυτό το μηχάνημα, 7) Είναι σύμφωνο με τις εξής οδηγίες και τις προσαρμογές τους στο εθνικό δίκαιο, 8) Για τα μηχανήματα παραρτήματος IV, 9) Αριθμός δήλωσης, 10) Κοινοποιημένος φορέας, 15) Εναρμονισμένα πρότυπα που χρησιμοποιούνται, 16) Πρότυπα ή τεχνικούς κανόνες που χρησιμοποιούνται, 16) Είναι σύμφωνο με τα εξής πρότυπα και τεχνικές διατάξεις, 17) Έν, 18) Ημερομηνία, 19) Ονομα του υπογράφοντος, 20) Θέση, 21) Υπογραφή.

es : Declaración DE de conformidad (original), 2) La sociedad, 3) Dirección, 4) expediente técnico, 5) Constructor de la máquina descrita a continuación, 6) Declara que esta máquina, 7) Está conforme a las siguientes directivas y a sus transposiciones en derecho nacional, 8) Para las máquinas anexo IV, 9) Número de certificación, 10) Organismo notificado, 15) normas armonizadas utilizadas, 16) Otras normas o especificaciones técnicas utilizadas, 17) Hecho en, 18) Fecha, 19) Nombre del signatario, 20) Función, 21) Firma.

et : 1) EÜ vastavusdeklaratsioon (algupärane), 2) Äriühing, 3) Aadress, 4) Tehniline dokumentatsioon, 5) Seadme tootja, 6) Kinnitab, et see toode, 7) On vastavuses järgmiste direktiivide ja nende riigisisesesse õigusesse ülevõtmiseks vastuvõetud õigusaktidega, 8) IV lisas loetletud seadmete puhul, 9) Tunnistuse number, 10) Tunnistuse number, 15) kasutatud ühtlustatud standardite, 16) Muud standardites või spetsifikatsioonides kasutatakse, 17) Väljaandmise koht, 18) Väljaandmise aeg, 19) Alkiriastaja nimi, 20) Amet, 21) Alkiri.

fi : 1) EY-vaatimustenmukaisuusvakuutus (alkuperäiset), 2) Yritys, 3) Osioite, 4) teknisen eritelmän, 5) Jäljessä kuvattun koneen valmistaja, 6) Vakuuttaa, että tämä kone, 7) Täyttää seuraavien direktiivien sekä niitä vastaavien kansallisten säännösten vaatimukset, 8) Liitteen IV koneiden osalta, 9) Todistuksen numero, 10) Ilmoitettu laitos, 15) yhdenmukaistettuja standardeja käytetään, 16) muita standardeja tai eritelmiä, 17) Paikka, 18) Aika, 19) Allekirjoittajan nimi, 20) Toimi, 21) Allekirjoitus.

ga : 1) « CE » dearbhú comhréireachta (bunaidh), 2) An comhlacht, 3) Seoladh, 4) comhad teicniúil, 5) Déantóir an innill a thuairiscítear thíos, 6) Dearbhaionn sé go bhfuil an t-inneall, 7) Go gcoinnn sé le na teoracha seo a leanas agus a trasuimh isteach i ndlí náisiúnta, 8) Le haghaidh innill an agusín IV, 9) Uimhir teastais, 10) Comhlacht a chuireadh i bhfios, 15) caighdeán comhchuíbhíne a úsáidtear, 16) caighdeán eile nó sonraíochtaí teicniúla a úsáidtear, 17) Déanta ag, 18) Dáta, 19) Ainm an tsinitheora, 20) Feidhm, 21) Síniú.

hu : 1) CE megfelelősségi nyilatkozat (eredeti), 2) A vállalat, 3) Cím, 4) műszaki dokumentáció, 5) Az alábbi gép gyártója, 6) Kijelenti, hogy a gép, 7) Megfelel az alábbi irányelveknek valamint azok hozosított előírásainak, 8) A IV. melléklet gépeihez, 9) Bizonylati szám, 10) Értécsített szervezet, 15) felhasznált harmonizált szabványok, 16) egyéb felhasznált műszaki szabványok és előírások hivatkozásai, 17) Kelt (hely), 18) Dátum, 19) Aláíró neve, 20) Funkció, 21) Aláírás.

is : 1) (Samræmisvottorð ESB (upprunalega), 2) Fyrirtæki, 3) Aðsetur, 4) Tæknilegar skrá, 5) Smíður tækisins sem lýst er hér á eftir, 6) Staðfestir að tæki, 7) Samræmist eftirfarandi stöðlum og staðfarslu þeirra með hljóðsjón af þjóðarrétti, 8) Fyrir tækin í aukakafla IV, 9) Staðfestingarnúmer, 10) Tilkynnt til, 15) samhæfða staða sem notaðir, 16) önnur staðlar eða forskrifir notað, 17) Staður, 18) Dagsetning, 19) Nafn undirritaðs, 20) Staða, 21) Undirskrift.

it : 1) Dichiarazione CE di conformità (originale), 2) La società, 3) Indirizzo, 4) fascicolo tecnico, 5) Costruttore della macchina descritta di seguito, 6) Dichiara che questa macchina, 7) È conforme alle direttive seguenti e alle relative trasposizioni nel diritto nazionale, 8) Per le macchine Allegato IV, 9) Numero di Attestazione, 10) Organismo notificato, 15) norme armonizzate applicate, 16) altre norme e specifiche tecniche applicate, 17) Stabilita a, 18) Data, 19) Nome del firmatario, 20) Funzione, 21) Firma.

lt : 1) CE atitikties deklaracija (originalas), 2) Bendrovė, 3) Adresas, 4) Techninė byla, 5) Žemiau nurodytas įrenginio gamintojas, 6) Pareiškia, kad šis įrenginys, 7) Atitinka toliau nurodytas direktyvas ir į nacionalinius teisės aktus perkeltas jų nuostatas, 8) Iekartam IV priedas dël mašinų, 9) Certifikato Nr, 10) Paskelbtoji įstaiga, 15) suderintus standartus naudojamus, 16) Kiti standartai ir technines specifikacijos, 17) Pasirašyta, 18) Data, 19) Pasirašiusio asmens vardas ir pavardė, 20) Pareigos, 21) Parašas.

lv : 1) EK atbilstības deklarācija (oriģināls), 2) Uzņēmums, 3) Adrese, 4) tehniskās lietas, 5) Tālāk aprakstītās iekārtas ražotājs, 6) Apliecinā, ka šī iekārtā, 7) Ir atbilstoša tālāk norādītajām direktīvām un to transpozīcijai nacionālajā likumdošanā, 8) Iekārtām IV pielikumā, 9) Iekārtām IV pielikumā, 9) Reģistrētā organizācija, 15) Lietotajiem saskaņotajiem standartiem, 16) lietotajiem tehniskajiem standartiem un specifikācijām, 17) Sastādīts, 18) Datums, 19) Parakstītāja vārds, 20) Amats, 21) Paraksts.

mt : 1) Dikjarazzjoni ta' Konformità KE (oriġinali), 2) Il-kumpanija, 3) Indirizz, 4) fajl tekniku, 5) Manifattriċi tal-magna deskritta hawn isfel, 6) Tiddikjara li din il-magna, 7) Hija konformi hija konformi mad-Direttivi segwenti u l-ligijiet li jimplimentawhom fil-ligji nazzjonali, 8) Għall-magni fl-Anness IV, 9) Numru taċ-certifikat, 10) Entità nnotifikata, 15) l-istandards armonizzati użati, 16) standards tekniki u specifikazzjonijiet oħra użati, 17) Magħmul f, 18) Data, 19) Isem il-firmatarju, 20) Kariga, 21) Firma.

nl : 1) EG-verklaring van overeenstemming (oorspronkelijke), 2) Het bedrijf, 3) Adres, 4) technische dossier, 5) Constructeur van de hierna genoemde machine, 6) Verklaart dat deze machine, 7) In overeenstemming is met de volgende richtlijnen en hun omzettingen in het nationale recht, 8) Voor machines van bijlage IV, 9) Goedgekeuringsnummer, 10) Aangezegde instelling, 15) gehanteerde geharmoniseerde normen, 16) andere gehanteerde technische normen en specificaties, 17) Opgemaakt te, 18) Datum, 19) Naam van ondergetekende, 20) Functie, 21) Handtekening.

no : 1) CE-samsvarserklæring (original), 2) Selskapet, 3) Adresse, 4) tekniske arkiv, 5) Fabrikant av følgende maskin, 6) Erklærer at denne maskinen, 7) Oppfyller kravene i følgende direktiver, med nasjonale gjennomføringsbestemmelser, 8) For maskinene i tillegg IV, 9) Attestnummer, 10) Notifisert organ, 15) harmoniserte standarder som brukes, 16) Andre standarder og spesifikasjoner brukt, 17) Utstedt i, 18) Dato, 19) Underskriverens navn, 20) Stilling, 21) Underskrift.

pl : 1) Deklaracja zgodności CE (oryginalne), 2) Spółka, 3) Adres, 4) dokumentacja technicznej, 5) Wykonawca maszyny opisanej poniżej, 6) Oświadca, że ta maszyna, 7) Jest zgodna z następującymi dyrektywami i odpowiadającymi przepisami prawa krajowego, 8) Dla maszyn załącznik IV, 9) Numer certyfikatu, 10) Jednostka certyfikująca, 15) zastosowanych norm zharmonizowanych, 16) innych zastosowanych norm technicznych i specyfikacji, 17) Sporządzono w, 18) Data, 19) Nazwisko podpisującego, 20) Stanowisko, 21) Podpis.

pt : 1) Declaração de conformidade CE (original), 2) A empresa, 3) Morada, 4) processo técnico, 5) Fabricante da máquina descrita abaixo, 6) Declara que esta máquina, 7) Está em conformidade às diretrizes seguintes e às suas transposições para o direito nacional, 8) Para as máquinas no anexo IV, 9) Número de certificado, 10) Entidade notificada, 15) normas harmonizadas utilizadas, 16) outras normas e especificações técnicas utilizadas, 17) Elaborado em, 18) Data, 19) Nome do signatário, 20) Cargo, 21) Assinatura.

ro : 1) Declarație de conformitate CE (originală), 2) Societatea, 3) Adresa, 4) cârtili tehnice, 5) Constructor al mașinii descrise mai jos, 6) Declară că prezenta mașină, 7) Este conformă cu directivele următoare și cu transpunerea lor în dreptul național, 8) Pentru mașinile din anexa IV, 9) Număr de atestare, 10) Organism notificat, 15) standardele armonizate utilizate, 16) alte standarde și specificații tehnice utilizate, 17) Intocmit la, 18) Data, 19) Numele persoanei care semnează, 20) Funcția, 21) Semnătură.

sk : 1) ES vyhlásenie o zhode (pôvodný), 2) Názov spoločnosti, 3) Adresa, 4) technickej dokumentácie, 5) Výrobca nižšie opísaného stroja, 6) Vyhlasuje, že tento stroj, 7) Je v súlade s nasledujúcimi smernicami a smernicami transponovanými do vnitrostátného práva, 8) Pre stroje v prílohe IV, 9) Číslo certifikátu, 10) Notifikačný orgán, 15) použité harmonizované normy, 16) použité iné technické normy a predpisy, 17) Miesto vydania, 18) Dátum vydania, 19) Meno podpisujúceho, 20) Funkcia, 21) Podpis.

sl : 1) ES Izjava o ustreznosti (izvirna), 2) Družba, 3) Naslov, 4) tehnične dokumentacije, 5) Proizvajalac tukaj opisanega stroja, 6) Izjavlja, da je ta stroj, 7) Ustreza naslednjim direktivam in njihovi transpoziciji v državno pravo, 8) Za stroje priloga IV, 9) Številka potrdila, 10) Obvestilo organu, 15) uporabljene harmonizirane standarde, 16) druge uporabljene tehnične standarde in zahteve, 17) V, 18) Datum, 19) Ime podpisnika, 20) Funkcija, 21) Podpis.

sv : 1) CE-försäkran om överensstämmelse (original), 2) Företaget, 3) Adress, 4) tekniska dokumentationen, 5) Konstruktor av nedan beskrivna maskin, 6) Försäkrar att denna maskin, 7) Överensstämmer med nedanstående direktiv och införlivandet av dem i nationell rätt, 8) För maskinerna i bilaga IV, 9) Nummer för godkännande, 10) Organism som underrättats, 15) Harmoniserade standarder som använts, 16) andra tekniska standarder och specifikationer som använts, 17) Upprättat i, 18) Datum, 19) Namn på den som undertecknat, 20) Befattning, 21) Namnteckning.

UKCA DECLARATION OF CONFORMITY

This document is a specimen of the UKCA Declaration of Conformity and includes the contents of the original declaration supplied with the machine.

This specimen and the original document may contain fields that are not applicable to your machine. These fields are left blank if not applicable.

Refer to the original Declaration of Conformity for all data applicable to your machine.

UKCA DECLARATION OF CONFORMITY

Manufacturer: **MANITOU BF**
Address: **430, RUE DE L'AUBINIÈRE - BP 10249
44158 ANCENIS CEDEX - FRANCE**
Authorized representative: **MANITOU UK
Ebble Industrial Estate - Dorset BH 31 6BB
Verwood - United Kingdom**

The manufacturer declares that the below described machinery:

Rough-terrain variable-reach truck

MT 730 H 75K ST5 S1

MT 930 H 75K ST5 S1

Complies with the following legislation:

The supply of Machinery (Safety) Regulations 2008, as amended

The machine is designed for the lifting of persons:

Applied procedure: Non applicable
Certificate number: Non applicable
Dated:
Approved body: Non applicable

Noise Emission in the Environment by Equipment for use Outdoors Regulations 2001, as amended

Applied procedure: Schedule 11
Approved body: SNCH
11 ROUTE DU LUXEMBOURG
5201 SANDWEILER - LUXEMBOURG

Sound power level:

Measured: dB (A)
Guaranteed: dB (A)

Electromagnetic Compatibility Regulations 2016, as amended

The following designated standards have been addressed:

EN1459 ; EN 12895

The following standards or technical guidance have been addressed:

At: _____ Date: _____
Name of signatory: _____
Position: _____
Company: _____
Signature: _____

SAFETY PLATES AND STICKERS

⚠ IMPORTANT ⚠

Clean all stickers and safety plates so that they are legible.
 Any safety plates and stickers which are illegible or damaged must be replaced.
 Check that stickers and safety plates are present after replacing any spare parts.

EXTERNAL PLATES AND STICKERS

REF.	REFERENCE	DESCRIPTION
1	234805	- Hydraulic coupling instruction
2	296998	- Maniscopic safety instruction
3	24653	- Slings point
4	52563320	- Tie-down point
5	52593979	- Boom safety
6	288430	- Repair instructions
7	268491	- Brake fluid instruction
8	305405	- Diesel fuel
9	52724662	- Lifting forbidden
10	307508	- Battery cut-off instruction
11	288174	- Repair instructions
12	52736521	- Overall height (OPTION)
13	289625	- Easy attachment connection (OPTION)
14	264476	- Boom electrical predisposition (OPTION)
15	52567646	- Emergency exit

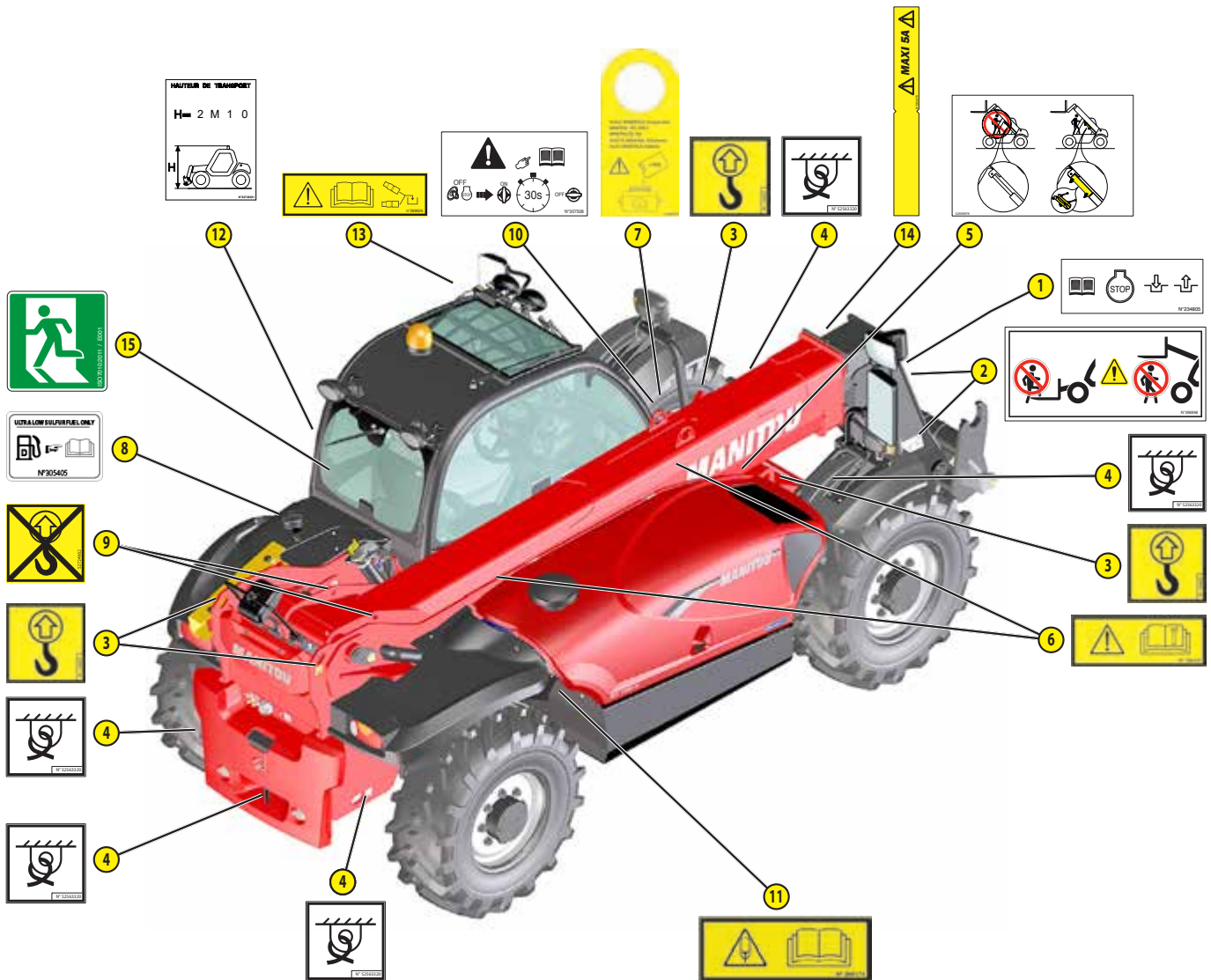

STICKERS AND PLATES UNDER THE ENGINE HOOD

REF.	REFERENCE	DESCRIPTION
1	233088	- Preheat rod (OPTION)
2	52506370	- Fuses
3	259398	- Water/diesel separator
4	52515083	- Anti-freeze
5	52552722	- Air conditioning (OPTION)

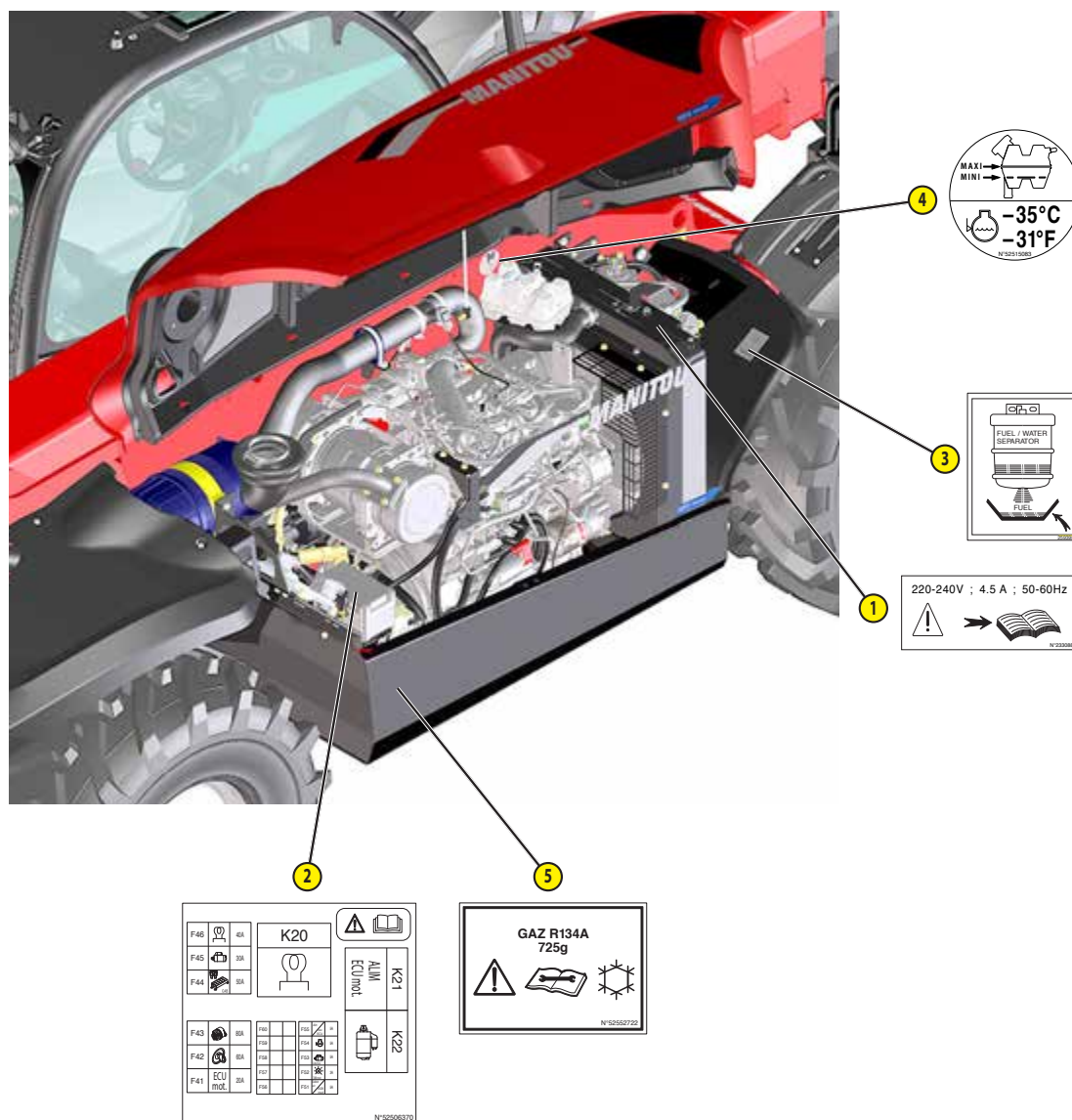

PLATES AND STICKERS IN THE CAB

REF.	REFERENCE	DESCRIPTION
1	240805	- Reach chart sheet
2	241621	- Safety instruction sheet
3	52509004	- Manipulator function sheet
4	52728457	- Tyres
5	52708169	- Fuse sheet
6	52708209	- Relay sheet
7	52678325	- Lubrication sheet
8	52730763	- Carriage lifting ring sheet (OPTION)MT 730
	52730770	- Carriage lifting ring sheet (OPTION)MT 930
9	52709083	- Axle locking cylinder test
10	52708563	- Hydraulic attachment locking function sheet (OPTION)
11	52728244	- Consumption sheet MT 730
12	52728245	- Consumption sheet MT 930
13	239594	- Sound power level
14	52698928	- Cab compliance
15	52651762	- Hydraulic controls activation
16	52655274	- Diesel exhaust particle filter regeneration function sheet
17	52580160	- Towing prohibited
18	290183	- Bucket instruction on telescope
19	52553499	- Operating mode management instruction
20	184276	- Steering selection
21	265284	- Lifting ring on carriage (OPTION)
23	52759172	- WARNING risk of misuse (For UK only)

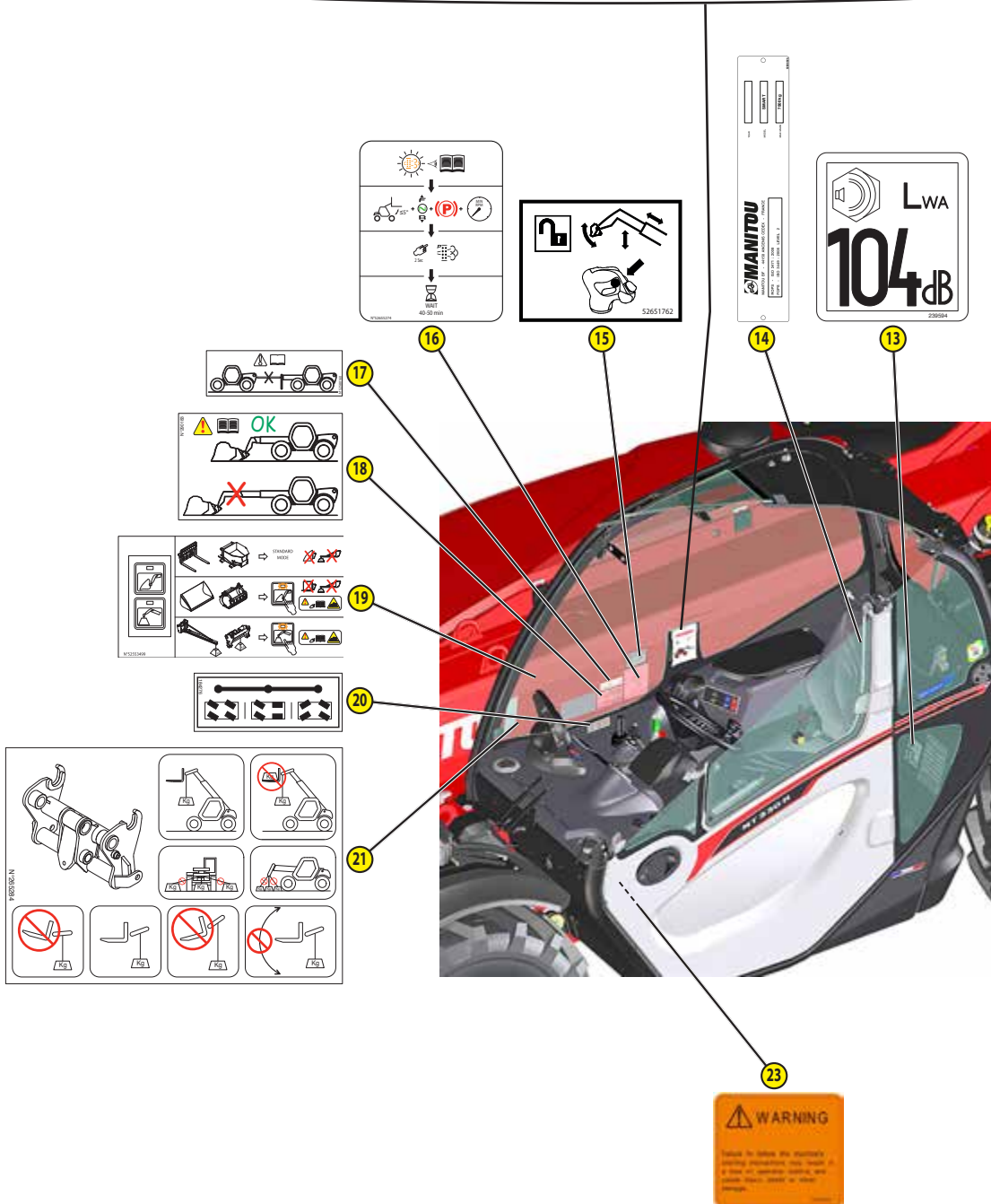
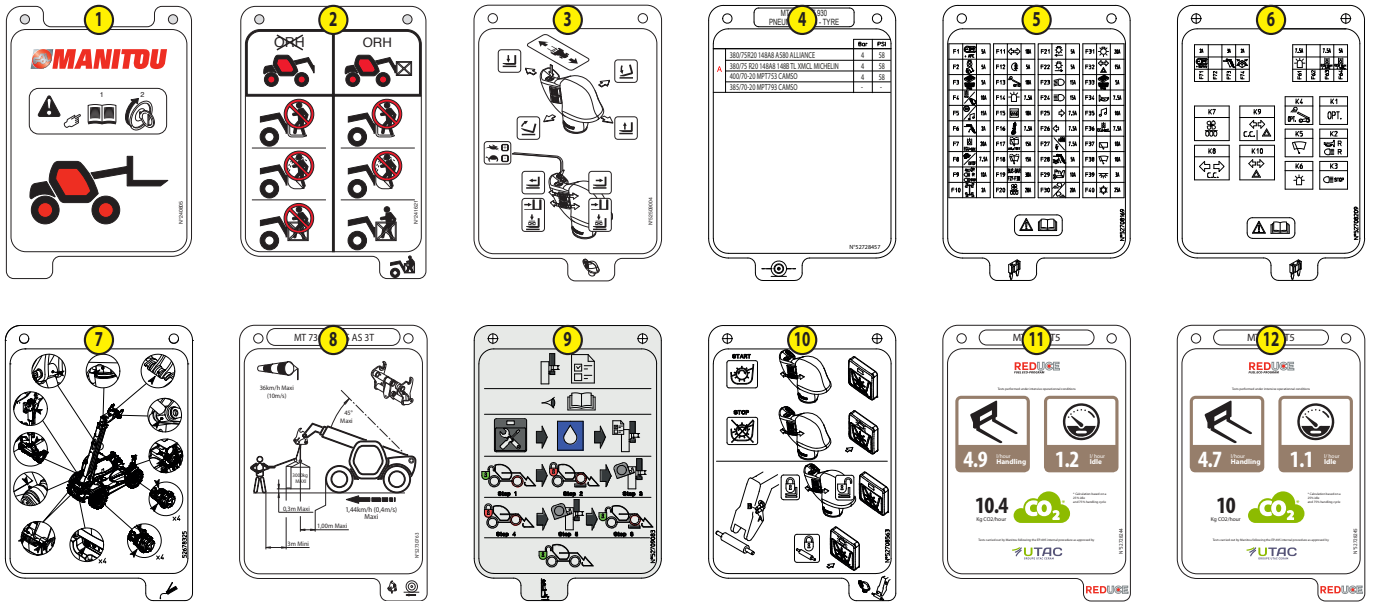

IDENTIFICATION OF THE LIFT TRUCK

As our policy is to promote a constant improvement in our products, our range of lift trucks may undergo certain modifications, without any obligation for us to advise our customers.

When you order parts, or when you require any technical information, always specify:

N.B.: For the owner's convenience, it is recommended that these numbers be entered in the spaces provided, at the time of the delivery of the lift truck.

For any further technical information regarding your lift truck, refer to: SPECIFICATIONS.

LIFT TRUCK MANUFACTURER'S PLATE

"Designation" Designation	
"Series" Series	
"Year of manufacture" Year of manufacture	
"Model year" Model year	
"Serial Number / Product Identification Number" Serial number / Product Identification Number	
"Unladen mass" Unladen weight	
"Power" Power	
"Authorized gross vehicle weight" Authorized Gross Vehicle Weight	
"Rated capacity" Rated capacity	
"Max vertical force (on trailer hook)" Maximum vertical force (on trailer hook)	
"Drag strain" Tractive force	



ENGINE

"MODEL" Model	
"FAMILY" Family	
"POWER" Power	



HYDROSTATIC PUMP

"MODEL" Model	
"CODE" Code	
"E1" Identification	
"SERNO" Serial number	
"SPEC" Specification	



HYDROSTATIC MOTOR

"MODEL" Model	
"CODE" Code	
"E1" Identification	
"SERNO" Serial number	
"SPEC" Specification	



FRONT AXLE

Type	
Serial number	
MANITOU reference	



REAR AXLE

Type	
Serial number	
MANITOU reference	

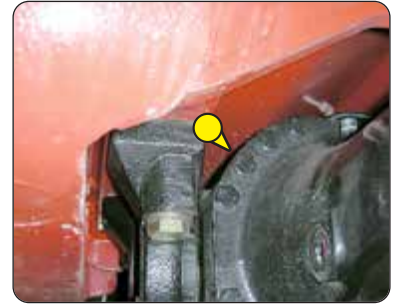

CAB

"Constructeur" Manufacturer	
"Type Cabine" Cab type	
"Numéro de série" Serial number	



BOOM

MANITOU reference	
Date of manufacture and manufacturer	



CHASSIS

Serial number / Product Identification Number	
---	--



ATTACHMENT MANUFACTURER'S PLATE

"MODELE" Model	
"N° série" Serial number	
"Année Fabrication" Year of manufacture	
"Masse à vide" Unladen weight	
"Centre de gravité" Center of gravity	
"Capacité Nominale" Rated capacity	
"Pression service" Working pressure	



ENGINE		
Type		KUBOTA V3307
Fuel		Diesel
Number of cylinders		4 in line
Suction		Supercharged
Injection system		Direct
Ignition sequence		1.3.4.2
Displacement	cm ³	3331
Bore and stroke	mm	94 x 120
Compression ratio		17,5
Nominal speed laden	rpm	2600
Min. rpm unladen	rpm	895
Max. rpm unladen	rpm	2800
Power ISO 14396	hp - kW	74,2 - 54,6
Power SAE J 1995 / ISO 3046-1	hp - kW	73,2 - 54,6
Maximum torque ISO 14396	Nm	265 at 1400 rpm
Air filtration efficiency	µm	3
Type of cooling		Coolant
Fan		Suction

TRANSMISSION		
Hydrostatic pump		DANFOSS
- Type		Variable displacement piston motor
- Forward/reverse selector		Electro-hydraulics
- Number of forward speeds		2 (1 slow and 1 fast)
- Number of reverse speeds		2 (1 slow and 1 fast)
Main pump		
- MAX - MIN. displacement	cm ³ /rev	0 - 53
- MAX. flow rate	ℓ/min	138
- Working pressure	bar	350
Booster pump		
- Displacement	cm ³ /rev	12
- MAX. flow rate	ℓ/min	31
- Boost pressure MAX. speed	bar	24 (transmission in neutral)
Hydrostatic motor		DANFOSS
- Type		variable bi-directional
- MAX - MIN. displacement	cm ³ /rev	29 - 110
Transfer box		DANA
Front axle		DANA
- Differential		45% limited slip differential
Rear axle		DANA
- Differential		Without locking
Drive wheels		Permanent 4 WD
- 2/4 wheel drive control		no
Front tires		ALLIANCE
- Size		380/75 R20 148A8 A580
- Pressure	bar	4
Rear tires		ALLIANCE
- Size		380/75 R20 148A8 A580
- Pressure	bar	4

ELECTRIC CIRCUIT		
Battery		12 V - 110 Ah - 750 A EN
Alternator		12 V - 80 A
- Type		A5TA59 77C
Starter		12 V - 3 kW
- Type		M008T50672

SOUND AND VIBRATION		
Sound pressure level in the driver's cab LpA (according to the standard EN 12053)	dB(A)	74 (cab closed); xx (cab open)
Sound pressure (according to Directive 2009/76)	dB(A)	xx (cab closed); xx (cab open)
Guaranteed sound power level in the environment LwA (according to Directive 2000/14/EC modified by Directive 2005/88/EC)	dB(A)	103 (measured); 104 (guaranteed)
Sound level in motion (according to Directive 2009/63)	dB(A)	xx
Average weighted acceleration on driver's body (according to the standard EN 13059)	m/s ²	XX
The average weighted acceleration transmitted to the driver's hand/arm system (according to standard ISO 5349-2)	m/s ²	< 2,5
Standard seat vibration	m/s ²	xx (lightweight operator); xx (heavyweight operator)

BRAKE SYSTEM	
Service brake	Hydraulic power brake
- Type of brake	Oil-immersed multi-disc
- Type of order	By foot on front axle
Parking brake	Low pressure hydraulic brake
- Type of brake	Oil-immersed multi-disc brake
- Type of order	Switch-operated electro-hydraulic

HYDRAULIC CIRCUIT			
Hydraulic pump		Double gear pump	
- Type		1st housing	2nd housing
- Displacement	cm ³	31	11
- Max. rating capacity unladen	ℓ/min	88	31
- Flow at 1600 rpm	ℓ/min	50	18
Filtration			
- Back	μm	10	10
- Suction	μm	125	10
Maximum working pressure		245	
- Telescoping circuit	bar	180 / 245	
- Lift circuit	bar	245 / 245	
- Tilt circuit	bar	245 / 245	
- Attachment circuit	bar	245	
- Steering circuit	bar	245	

HYDRAULIC MOVEMENTS		
Longitudinal stability limiter and warning device		Electronics
Lifting motions (boom retracted)		
- Unladen lifting	s - m/min	9,42 - 28,5
- Laden lifting	s - m/min	9,77 - 27,5
- Unladen lowering	s - m/min	7,53 - 35,7
- Laden lowering	s - m/min	7,53 - 35,7
Telescoping motions (boom raised)		
- Unladen extending	s - m/min	7,43 - 21,2
- Laden extending	s - m/min	7,5 - 21,4
- Unladen retracting	s - m/min	8,96 - 17,8
- Laden retracting	s - m/min	8,83 - 18
Tilting movements		
- Unladen digging	s - °/s	2,81 - 45,2
- Unladen dump	s - °/s	2,15 - 59,1

SPECIFICATIONS AND WEIGHTS			
Speed of movement for lift truck in standard configuration on flat ground			
• Front unladen	• 1 Slow	km/h	12
	• 1 fast	km/h	25
• Rear unladen	• 1 Slow	km/h	12
	• 1 fast	km/h	25
Standard attachment		CAF 1000/3	
- Weight of attachment (without forks)	kg	135	
- Weight of forks (each)	kg	52,5	
Rated capacity with standard attachment	kg	3000	
Tipping load at maximum reach on tires	kg	950	
Distance from the center of gravity of the load to the base of the forks	mm	500	
Standard lifting height	mm	6900	
Lift truck weight without attachment	kg	5640	
Weight of lift truck with standard attachment			
- Unladen	kg	5880	
- At rated load	kg	8880	
Weight per axle with standard attachment (transport position)			
- Front unladen	kg	2750	
- Rear unladen	kg	3130	
- Front rated load	kg	7890	
- Rear rated load	kg	990	
Weight per axle with standard attachment (boom extended)			
- Front rated load	kg	6210	
- Rear rated load	kg	620	
Tractive effort on the coupling hook			
- Unladen (sliding)	daN	3860	
- At rated load (transmission setting)	daN	3860	
Break-out force with bucket (according to standard ISO 8313)	daN		

ENGINE		
Type		KUBOTA V3307
Fuel		Diesel
Number of cylinders		4 in line
Suction		Supercharged
Injection system		Direct
Ignition sequence		1.3.4.2
Displacement	cm ³	3331
Bore and stroke	mm	94 x 120
Compression ratio		17,5
Nominal speed laden	rpm	2600
Min. rpm unladen	rpm	895
Max. rpm unladen	rpm	2800
Power ISO 14396	hp - kW	74,2 - 54,6
Power SAE J 1995 / ISO 3046-1	hp - kW	73,2 - 54,6
Maximum torque ISO 14396	Nm	265 at 1400 rpm
Air filtration efficiency	µm	3
Type of cooling		Coolant
Fan		Suction

TRANSMISSION		
Hydrostatic pump		DANFOSS
- Type		Variable displacement piston motor
- Forward/reverse selector		Electro-hydraulics
- Number of forward speeds		2 (1 slow and 1 fast)
- Number of reverse speeds		2 (1 slow and 1 fast)
Main pump		
- MAX - MIN. displacement	cm ³ /rev	0 - 69
- MAX. flow rate	ℓ/min	243
- Working pressure	bar	400
Booster pump		
- Displacement	cm ³ /rev	14
- MAX. flow rate	ℓ/min	36
- Boost pressure MAX. speed	bar	26 (transmission in neutral)
Hydrostatic motor		DANFOSS
- Type		variable bi-directional
- MAX - MIN. displacement	cm ³ /rev	29 - 110
Transfer box		DANA
Front axle		DANA
- Differential		45% limited slip differential
Rear axle		DANA
- Differential		Without locking
Drive wheels		Permanent 4 WD
- 2/4 wheel drive control		no
Front tires		ALLIANCE
- Size		380/75 R20 148A8 A580
- Pressure	bar	4
Rear tires		ALLIANCE
- Size		380/75 R20 148A8 A580
- Pressure	bar	4

ELECTRIC CIRCUIT		
Battery		12 V - 110 Ah - 750 A EN
Alternator		12 V - 80 A
- Type		A5TA59 77C
Starter		12 V - 3 kW
- Type		M008T50672

SOUND AND VIBRATION		
Sound pressure level in the driver's cab LpA (according to the standard EN 12053)	dB(A)	74 (cab closed); xx (cab open)
Sound pressure (according to Directive 2009/76)	dB(A)	xx (cab closed); xx (cab open)
Guaranteed sound power level in the environment LwA (according to Directive 2000/14/EC modified by Directive 2005/88/EC)	dB(A)	103 (measured); 104 (guaranteed)
Sound level in motion (according to Directive 2009/63)	dB(A)	xx
Average weighted acceleration on driver's body (according to the standard EN 13059)	m/s ²	XX
The average weighted acceleration transmitted to the driver's hand/arm system (according to standard ISO 5349-2)	m/s ²	< 2,5
Standard seat vibration	m/s ²	xx (lightweight operator); xx (heavyweight operator)

BRAKE SYSTEM	
Service brake	Hydraulic power brake
- Type of brake	Oil-immersed multi-disc
- Type of order	By foot on front axle
Parking brake	Low pressure hydraulic brake
- Type of brake	Oil-immersed multi-disc brake
- Type of order	Switch-operated electro-hydraulic

HYDRAULIC CIRCUIT			
Hydraulic pump		Double gear pump	
- Type		1st housing	2nd housing
- Displacement	cm ³	31	11
- Max. rating capacity unladen	ℓ/min	88	31
- Flow at 1600 rpm	ℓ/min	50	18
Filtration			
- Back	μm	10	10
- Suction	μm	125	10
Maximum working pressure		245	
- Telescoping circuit	bar	180 / 245	
- Lift circuit	bar	245 / 245	
- Tilt circuit	bar	245 / 245	
- Attachment circuit	bar	245	
- Steering circuit	bar	245	

HYDRAULIC MOVEMENTS			
Longitudinal stability limiter and warning device		Electronics	
Lifting motions (boom retracted)			
- Unladen lifting	s - m/min	10,24 - 26,3	
- Laden lifting	s - m/min	10,44 - 25,8	
- Unladen lowering	s - m/min	7,95 - 33,9	
- Laden lowering	s - m/min	7,6 - 35,4	
Telescoping motions (boom raised)			
- Unladen extending	s - m/min	9,89 - 13,9	
- Laden extending	s - m/min	10,28 - 14,4	
- Unladen retracting	s - m/min	9,48 - 15,1	
- Laden retracting	s - m/min	9,11 - 15,7	
Tilting movements			
- Unladen digging	s - °/s	3,06 - 41,5	
- Unladen dump	s - °/s	2,44 - 52	

SPECIFICATIONS AND WEIGHTS			
Speed of movement for lift truck in standard configuration on flat ground			
• Front unladen	• 1 Slow	km/h	12
	• 1 fast	km/h	25
• Rear unladen	• 1 Slow	km/h	12
	• 1 fast	km/h	25
Standard attachment		CAF 1000/3	
- Weight of attachment (without forks)	kg	135	
- Weight of forks (each)	kg	52,5	
Rated capacity with standard attachment	kg	3000	
Tipping load at maximum reach on tires	kg	450	
Distance from the center of gravity of the load to the base of the forks	mm	500	
Standard lifting height	mm	8850	
Lift truck weight without attachment	kg	6260	
Weight of lift truck with standard attachment			
- Unladen	kg	6500	
- At rated load	kg	9500	
Weight per axle with standard attachment (transport position)			
- Front unladen	kg	2950	
- Rear unladen	kg	3550	
- Front rated load	kg	8040	
- Rear rated load	kg	1460	
Weight per axle with standard attachment (boom extended)			
- Front rated load	kg	6350	
- Rear rated load	kg	600	
Tractive effort on the coupling hook			
- Unladen (sliding)	daN	3860	
- At rated load (transmission setting)	daN	3860	
Break-out force with bucket (according to standard ISO 8313)	daN		

		PRESSURE (bar)	LOAD PER TIRE (kg)			
			FRONT UNLADEN	FRONT (LADEN)	REAR (UNLADEN)	REAR (LADEN)
ALLIANCE	380/75R20 148A8 A580	4	1375	3945	1565	495
CAMSO	385/70-20 MPT793	-				
CAMSO	400/70-20 MPT753	4				
MICHELIN	380/75 R20 148A8 148B TL XMCL	4				

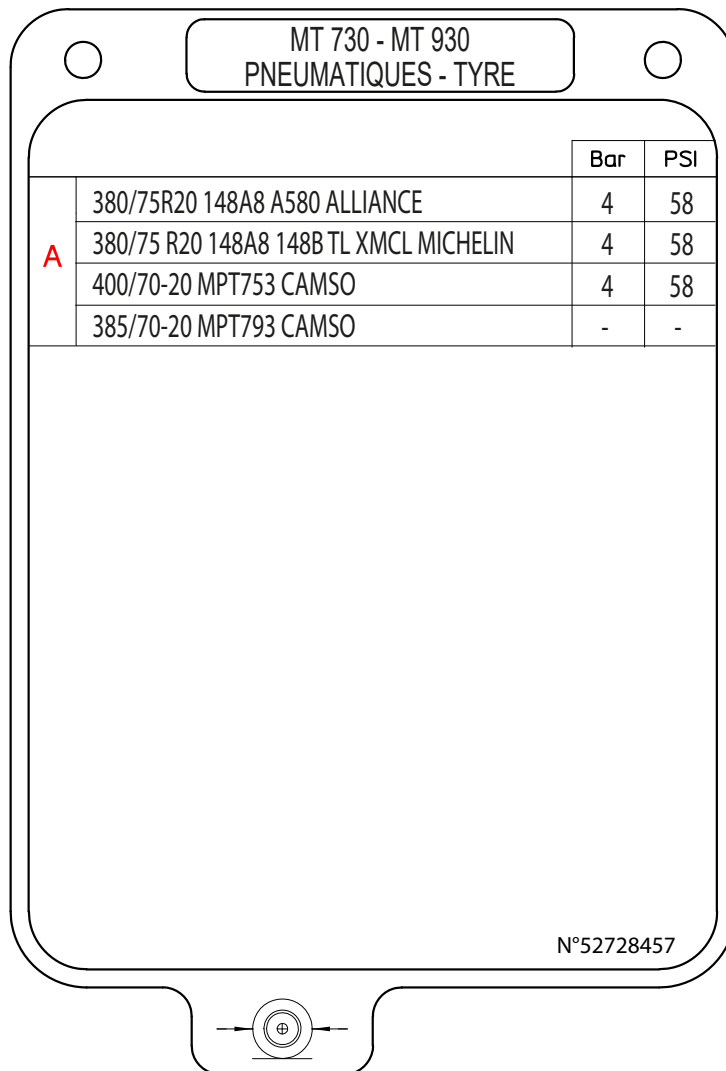

		PRESSURE (bar)	LOAD (kg)	PRESSURE ON THE CONTACT SURFACE (kg/cm ²)		GROUND CONTACT AREA (cm ²)	
				HARD GROUND	SOFT GROUND	HARD GROUND	SOFT GROUND
ALLIANCE	380/75R20 148A8 A580	4	495	4,46	1,55	111	318
			1375	5,86	2,12	235	650
			1565	5,78	2,07	271	756
			3945	8,15	2,96	484	1331
CAMSO	385/70-20 MPT793	-	495	5,16	1,94	96	255
			1375	6,88	3,31	200	415
			1565	7,18	3,52	218	444
			3945	9,86	5,42	400	728
CAMSO	400/70-20 MPT753	4	495	5,50	1,51	90	328
			1375	6,98	2,23	197	617
			1565	7,28	2,37	215	660
			3945	9,39	3,56	420	1108
MICHELIN	380/75 R20 148A8 148B TL XMCL	4	495	3,00	1,01	165	490
			1375	6,55	1,99	210	690
			1565	6,96	2,14	225	730
			3945	10,66	3,32	370	1190

		PRESSURE (bar)	LOAD PER TIRE (kg)			
			FRONT UNLADEN	FRONT (LADEN)	REAR (UNLADEN)	REAR (LADEN)
ALLIANCE	380/75R20 148A8 A580	4	1475	4020	1775	730
CAMSO	385/70-20 MPT793	-				
CAMSO	400/70-20 MPT753	4				
MICHELIN	380/75 R20 148A8 148B TL XMCL	4				

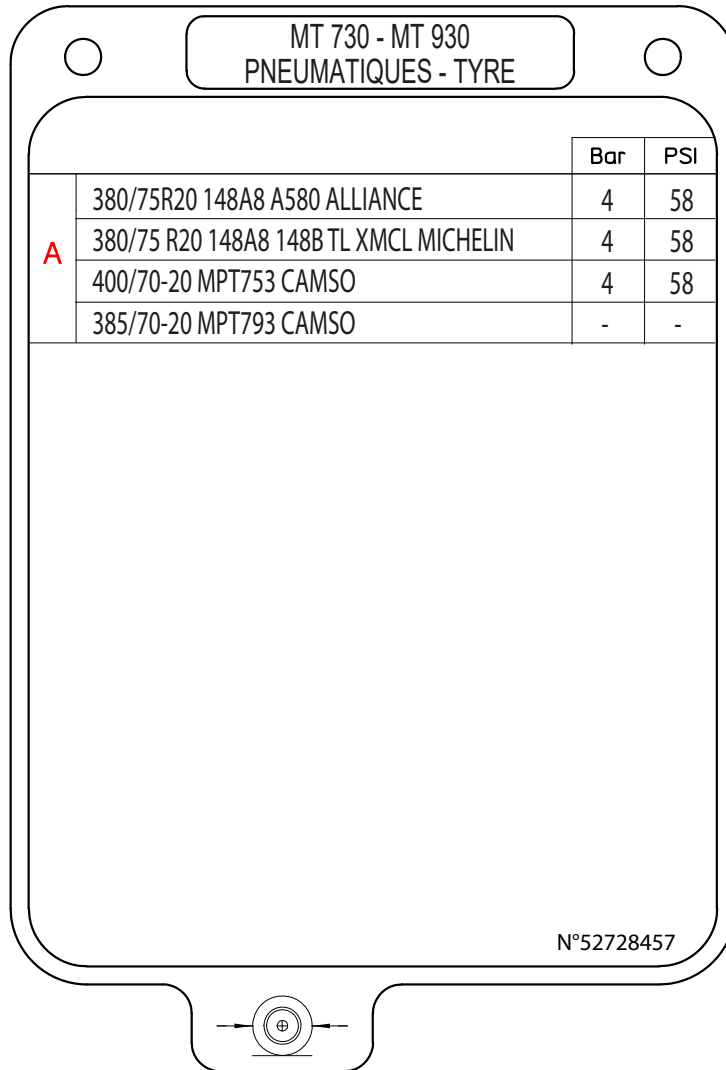

		PRESSURE (bar)	LOAD (kg)	PRESSURE ON THE CONTACT SURFACE (kg/cm ²)		GROUND CONTACT AREA (cm ²)	
				HARD GROUND	SOFT GROUND	HARD GROUND	SOFT GROUND
ALLIANCE	380/75R20 148A8 A580	4	730	4,87	1,82	150	402
			1475	5,78	2,07	255	714
			1775	6,27	2,19	283	809
			4020	7,92	2,90	507	1387
CAMSO	385/70-20 MPT793	-	730	5,75	2,41	127	303
			1475	7,02	3,43	210	430
			1775	7,46	3,74	238	475
			4020	9,95	5,47	404	735
CAMSO	400/70-20 MPT753	4	730	5,75	2,41	127	303
			1475	7,02	3,43	210	430
			1775	7,46	3,74	238	475
			4020	9,95	5,47	404	735
MICHELIN	380/75 R20 148A8 148B TL XMCL	4	730	4,06	1,30	180	560
			1475	6,70	2,08	220	710
			1775	7,55	2,28	235	780
			4020	10,72	3,35	375	1200

DIMENSIONS

MT 730 H 75K ST5 S1

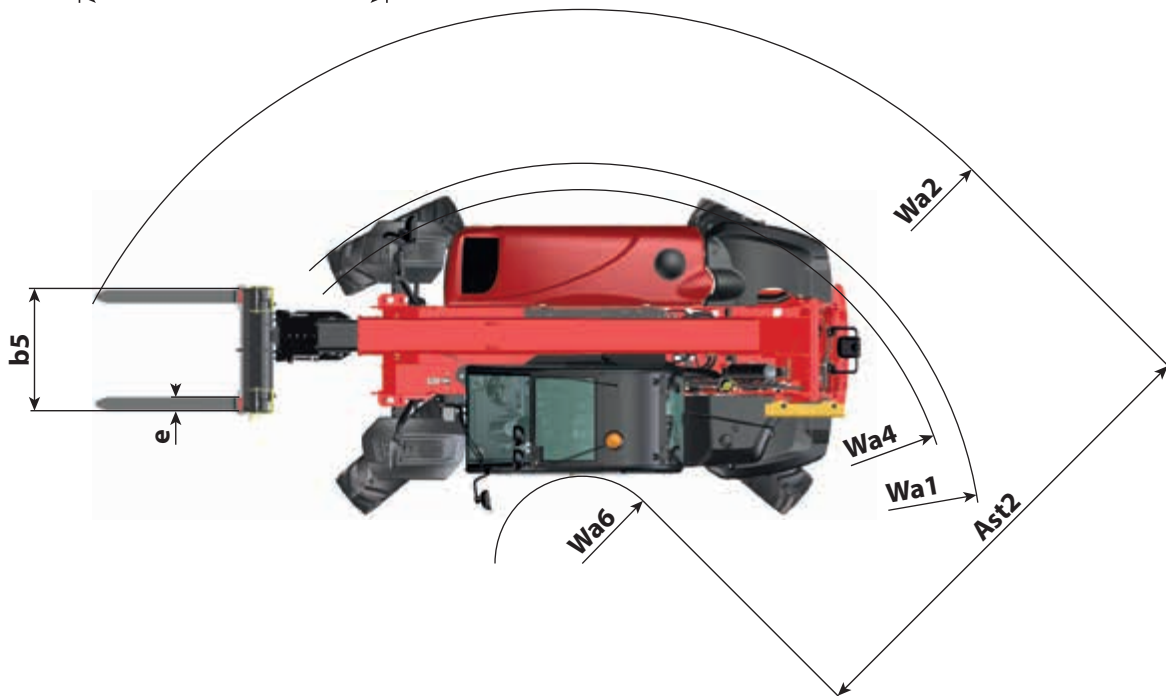
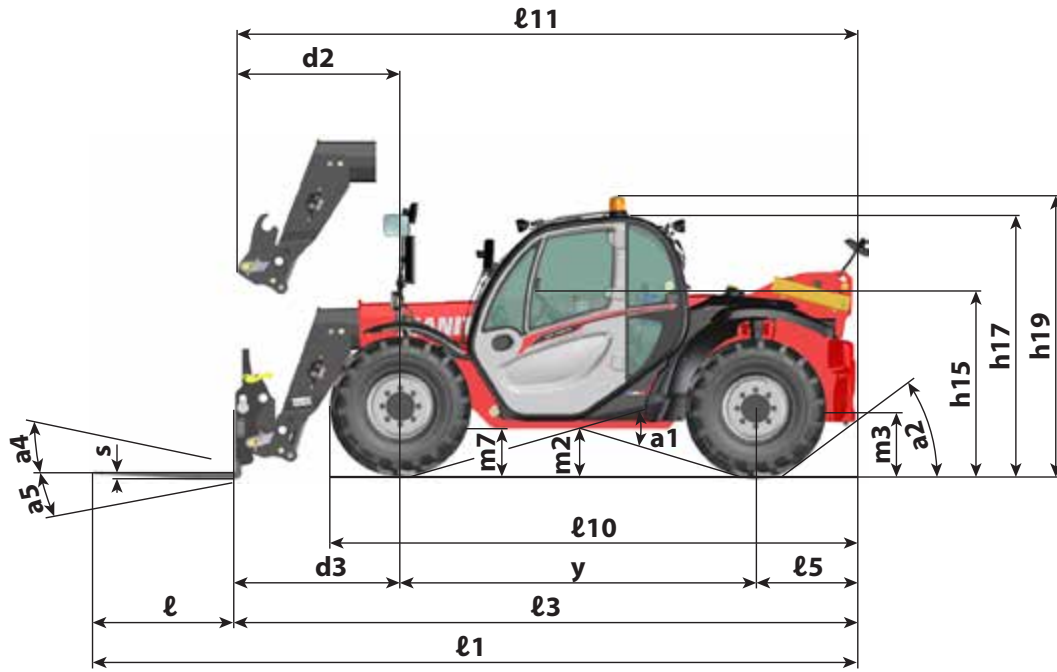

MACHINE LENGTH	ℓ1	mm	5768
	ℓ3	mm	4698
	ℓ5	mm	756
	ℓ10	mm	3985
	ℓ11	mm	4679
MACHINE WIDTH	b1	mm	1990
	b4	mm	797
	b5	mm	924
	b9	mm	1610
	b10	mm	1610
MACHINE HEIGHT	h15	mm	1381
	h17	mm	1997
	h19	mm	2105
DISTANCE	d2	mm	1233
	d3	mm	1252
AISLE WIDTH	Ast2	mm	3068
ATTACHMENT	ℓ	mm	1070
	e	mm	100
	s	mm	50
TURNING RADIUS	Wa1	mm	3335
	Wa2	mm	4390
	Wa4	mm	3145
	Wa6	mm	1322
GROUND CLEARANCE	m2	mm	345
	m3	mm	379
	m7	mm	377
ANGLE	a1	°	33
	a2	°	37
	a4	°	11
	a5	°	116
WHEELBASE	y	mm	2690

STANDARD WITH TIRES "A"

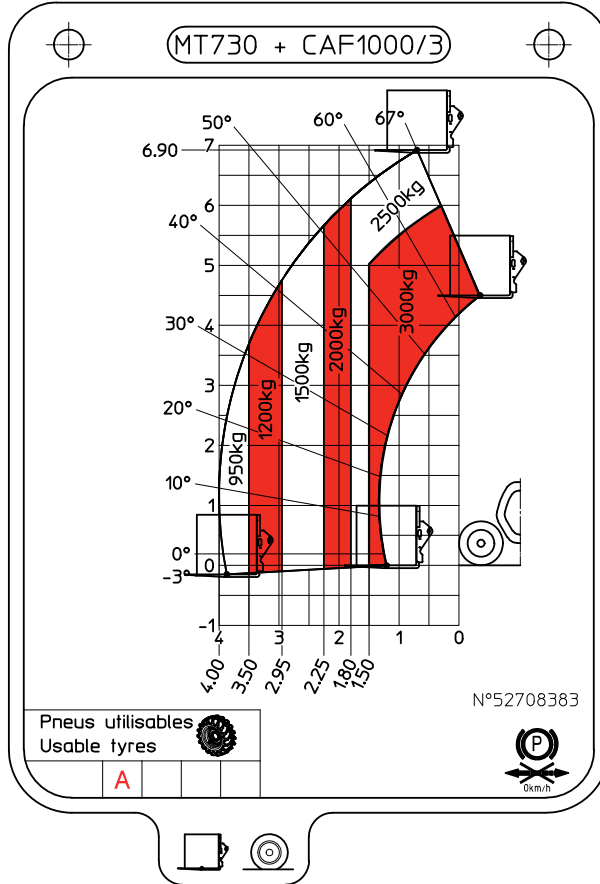

DIMENSIONS

MT 930 H 75K ST5 S1

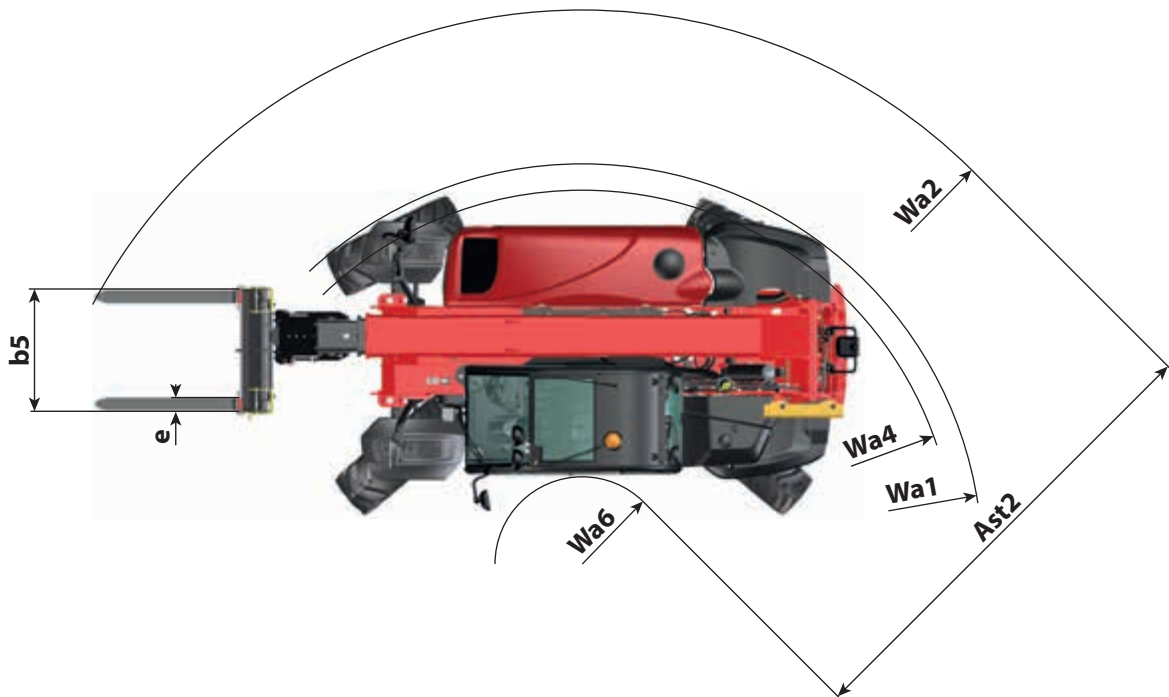
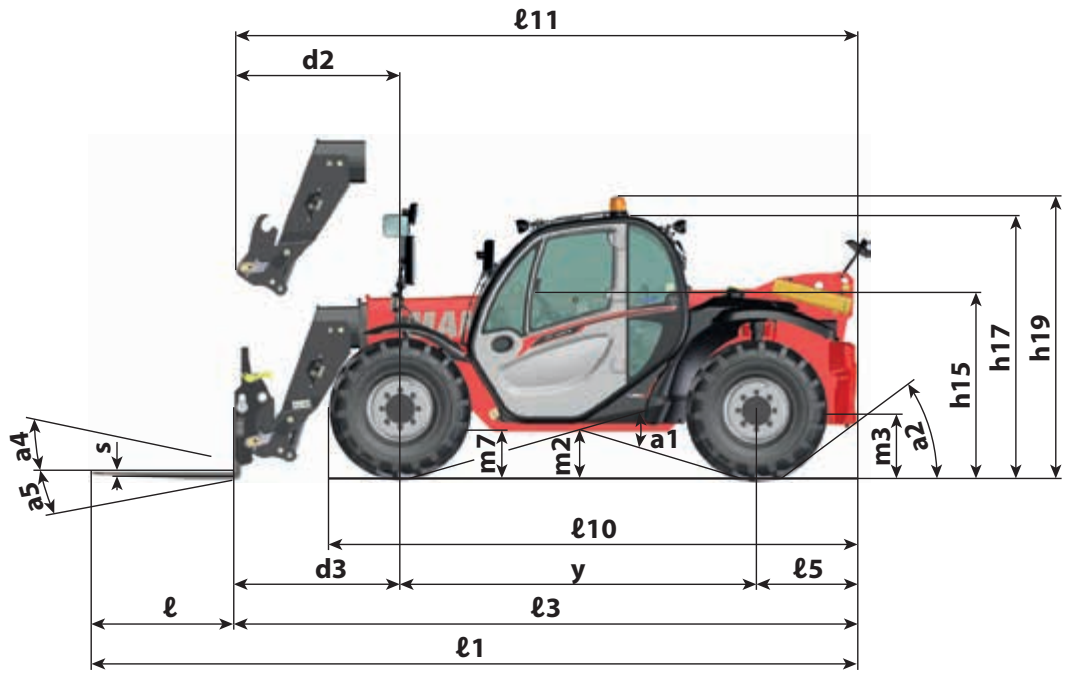

MACHINE LENGTH	ℓ1	mm	5768
	ℓ3	mm	4698
	ℓ5	mm	756
	ℓ10	mm	3985
	ℓ11	mm	4679
MACHINE WIDTH	b1	mm	1990
	b4	mm	797
	b5	mm	924
	b9	mm	1610
	b10	mm	1610
MACHINE HEIGHT	h15	mm	1381
	h17	mm	1997
	h19	mm	2105
DISTANCE	d2	mm	1233
	d3	mm	1252
AISLE WIDTH	Ast2	mm	3068
ATTACHMENT	ℓ	mm	1070
	e	mm	100
	s	mm	50
TURNING RADIUS	Wa1	mm	3335
	Wa2	mm	4390
	Wa4	mm	3145
	Wa6	mm	1322
GROUND CLEARANCE	m2	mm	345
	m3	mm	379
	m7	mm	377
ANGLE	a1	°	33
	a2	°	37
	a4	°	11
	a5	°	116
WHEELBASE	y	mm	2690

STANDARD WITH TIRES "A"

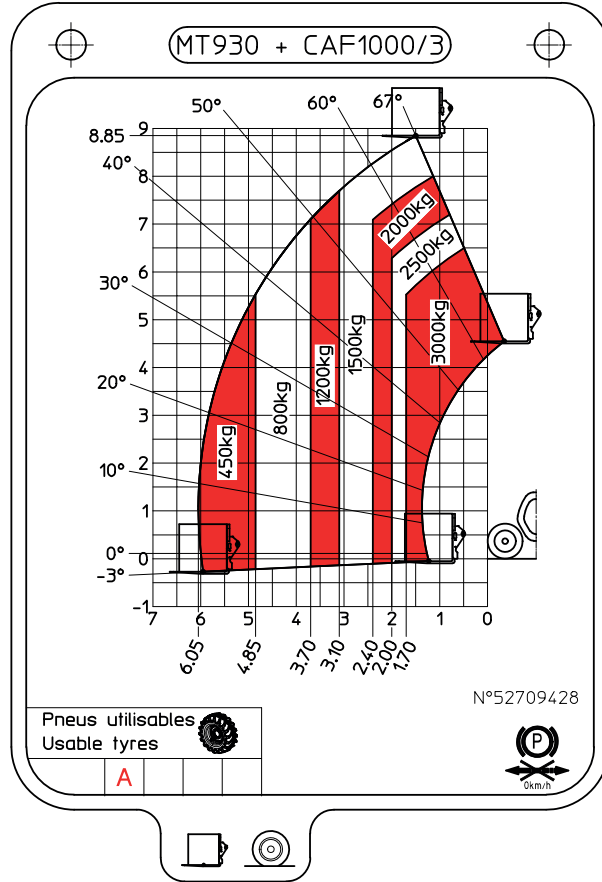

We use European standard EN15830 relating to operator visibility.

- Adhere to the instructions for optimizing operator visibility in the immediate vicinity (\leq 1 - OPERATING AND SAFETY INSTRUCTIONS: OPERATOR INSTRUCTIONS: OPERATING INSTRUCTIONS WITH AND WITHOUT LOAD: D - VISIBILITY).

DESCRIPTION AND ADJUSTMENT OF REAR-VIEW MIRRORS

- 1 - LEFT REAR-VIEW MIRROR
- 2 - MAIN RIGHT REAR-VIEW MIRROR
- 3 - CENTRAL RIGHT REAR-VIEW MIRROR
- 4 - UPPER RIGHT REAR-VIEW MIRROR
- 5 - INSIDE REAR-VIEW MIRROR (OPTION)
- 6 - REAR-VIEW MIRROR (OPTION)

- Place the lift truck on level ground with the engine stopped, and the boom retracted and lowered as far as possible.
- Note the position of the reference points ●...○ in the illustrations, to see and correctly adjust the rear-view mirrors.

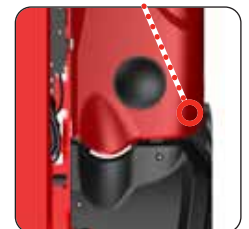
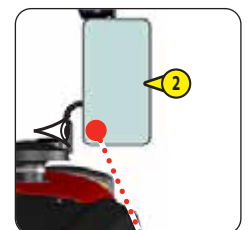
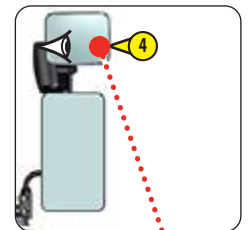
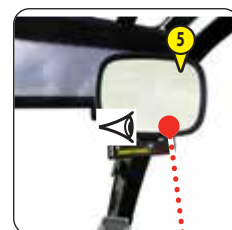
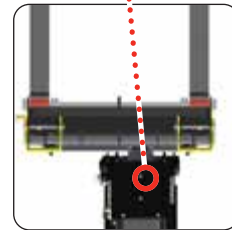
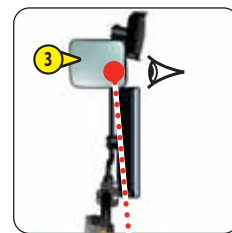
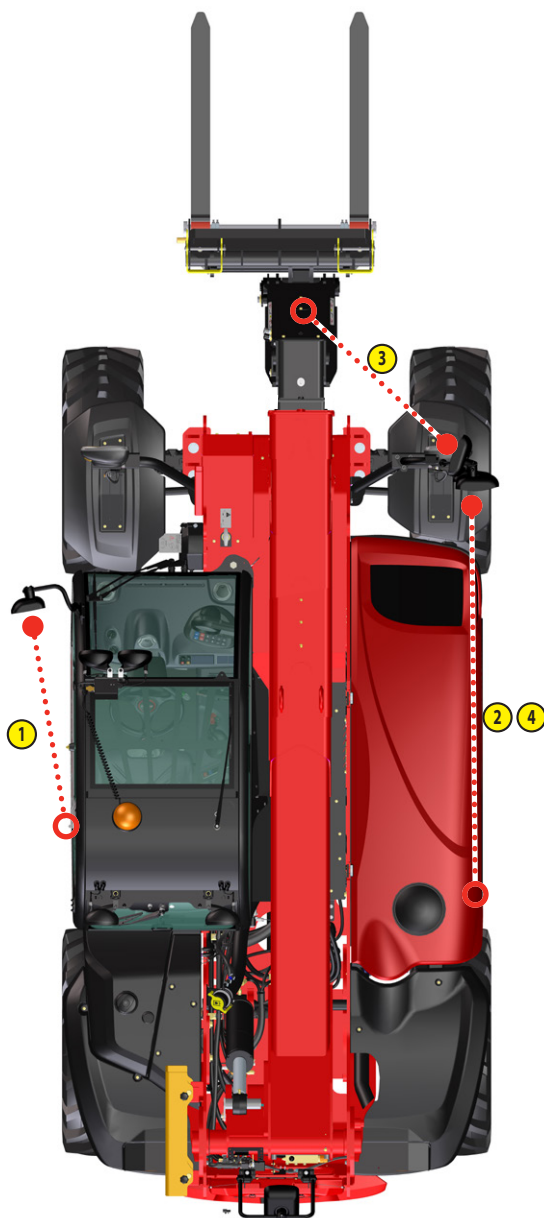
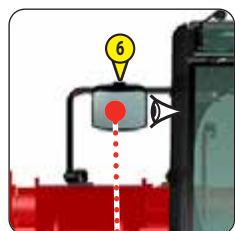
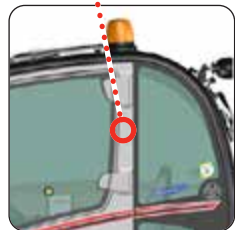
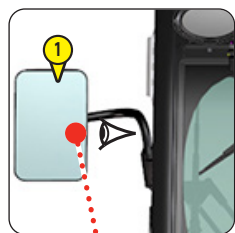

DIRECT AND/OR INDIRECT VISIBILITY BLIND SPOT ZONES

The two diagrams below indicate blind spot zones on the visibility test circle (12 m radius) and the 1 m rectangular zone around the lift truck, according to tests carried out in accordance with EN 15830.

HANDLING SUSPENDED LOADS (Test carried out in accordance with 6.3.3 of EN 15830)

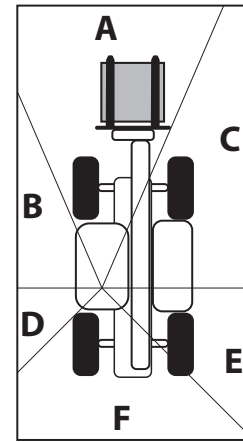
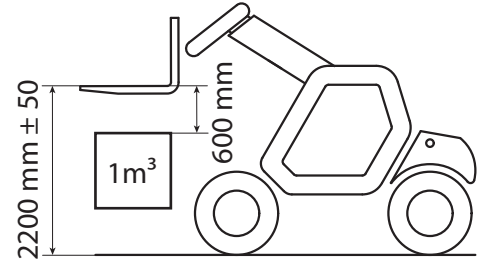
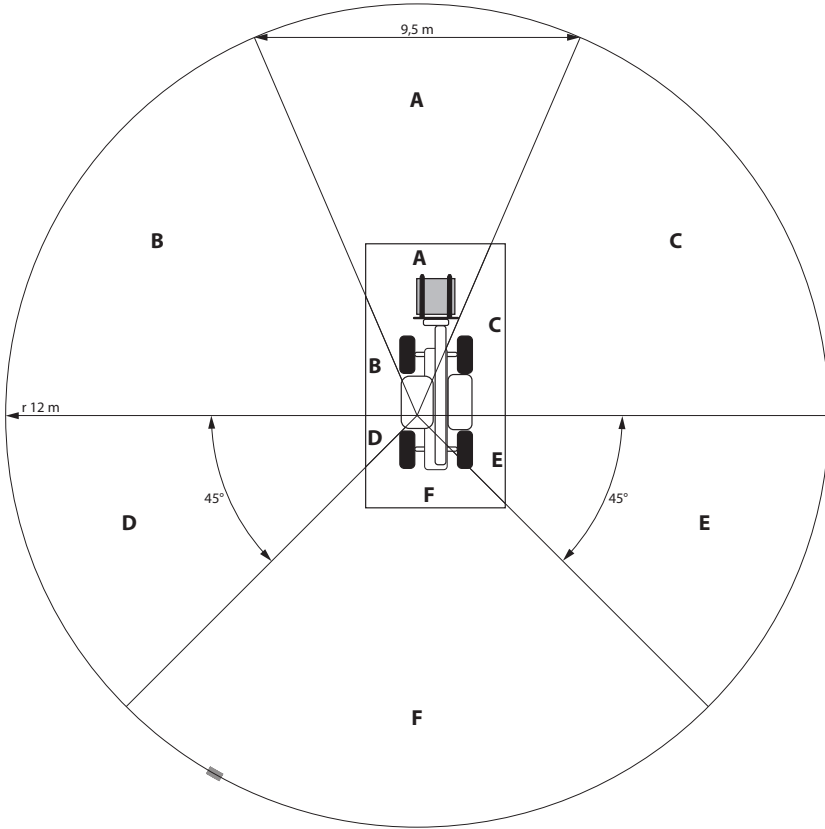

LOADING THE TRAILER (Test carried out in accordance with 6.3.4 of EN 15830)

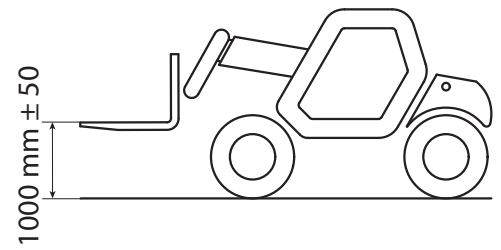
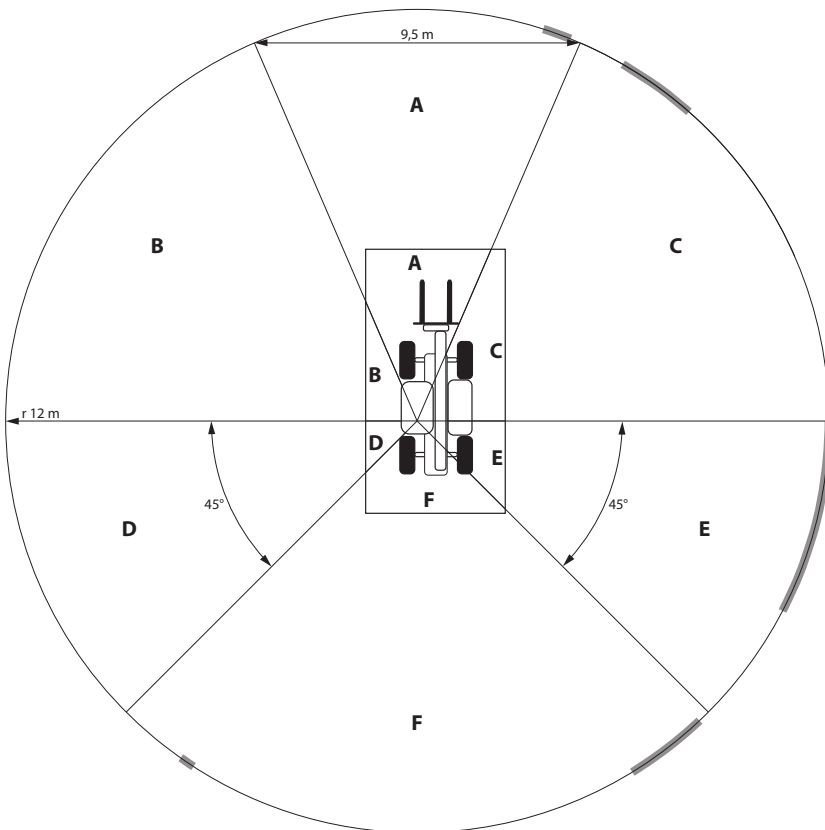

We use European standard EN15830 relating to operator visibility.

- Adhere to the instructions for optimizing operator visibility in the immediate vicinity (≤ 1 - OPERATING AND SAFETY INSTRUCTIONS: OPERATOR INSTRUCTIONS: OPERATING INSTRUCTIONS WITH AND WITHOUT LOAD: D - VISIBILITY).

DESCRIPTION AND ADJUSTMENT OF REAR-VIEW MIRRORS

- 1 - LEFT REAR-VIEW MIRROR
- 2 - MAIN RIGHT REAR-VIEW MIRROR
- 3 - CENTRAL RIGHT REAR-VIEW MIRROR
- 4 - UPPER RIGHT REAR-VIEW MIRROR
- 5 - INSIDE REAR-VIEW MIRROR (OPTION)
- 6 - REAR-VIEW MIRROR (OPTION)

- Place the lift truck on level ground with the engine stopped, and the boom retracted and lowered as far as possible.
- Note the position of the reference points ●...○ in the illustrations, to see and correctly adjust the rear-view mirrors.

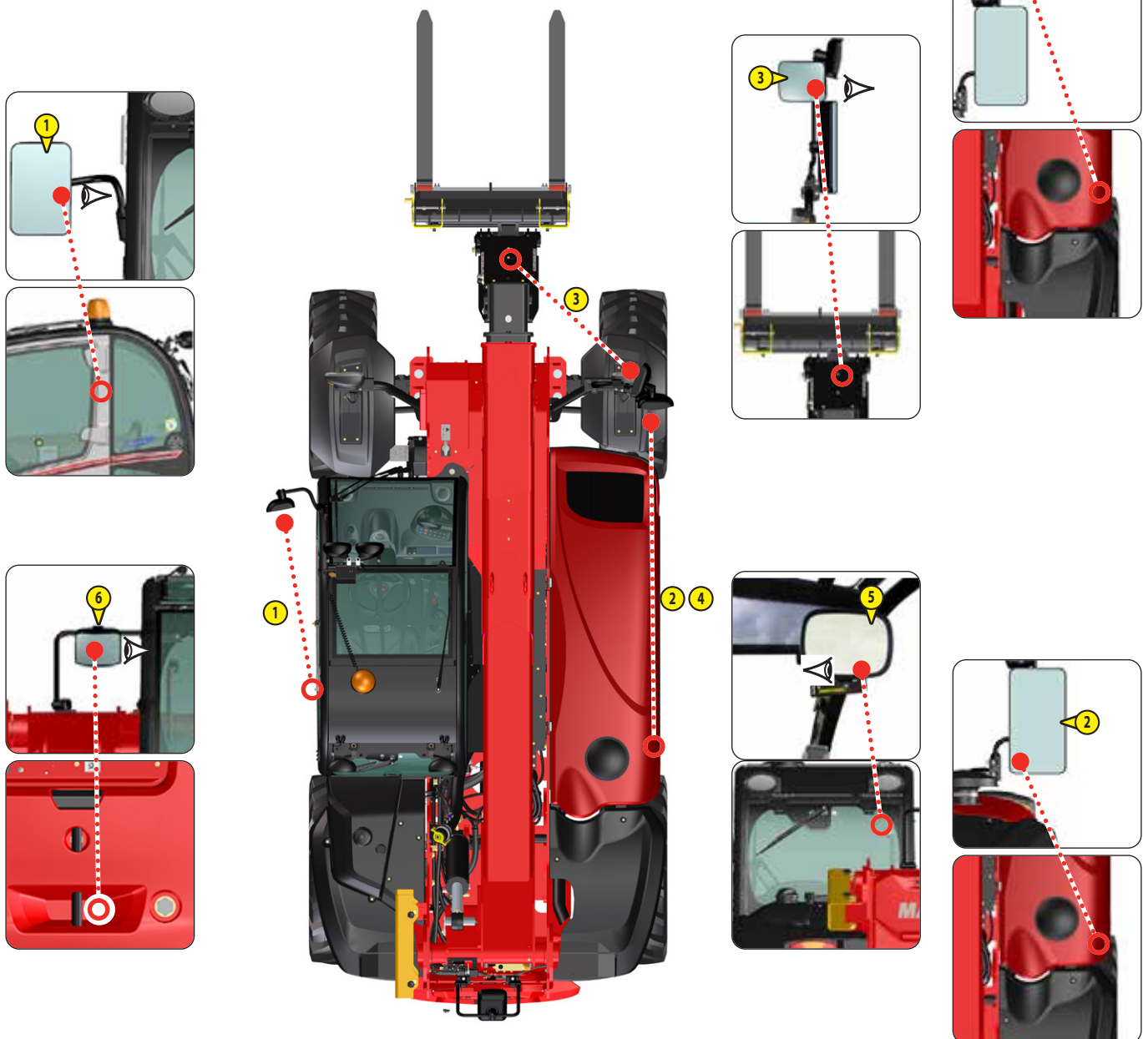
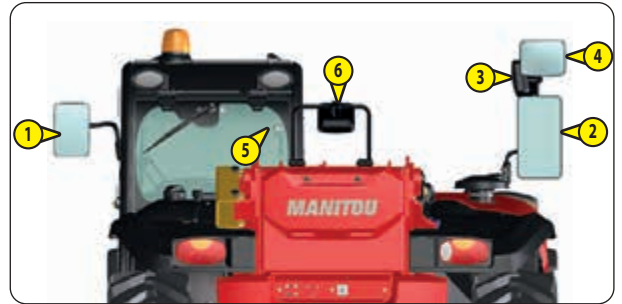

DIRECT AND/OR INDIRECT VISIBILITY BLIND SPOT ZONES

The two diagrams below indicate blind spot zones on the visibility test circle (12 m radius) and the 1 m rectangular zone around the lift truck, according to tests carried out in accordance with EN 15830.

HANDLING SUSPENDED LOADS (Test carried out in accordance with 6.3.3 of EN 15830)

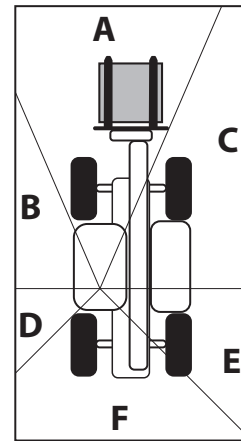
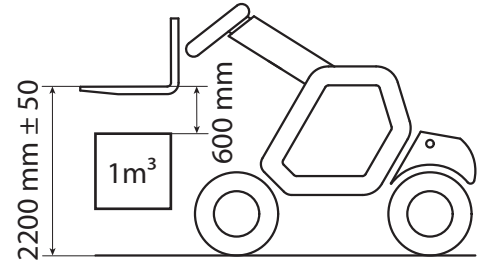
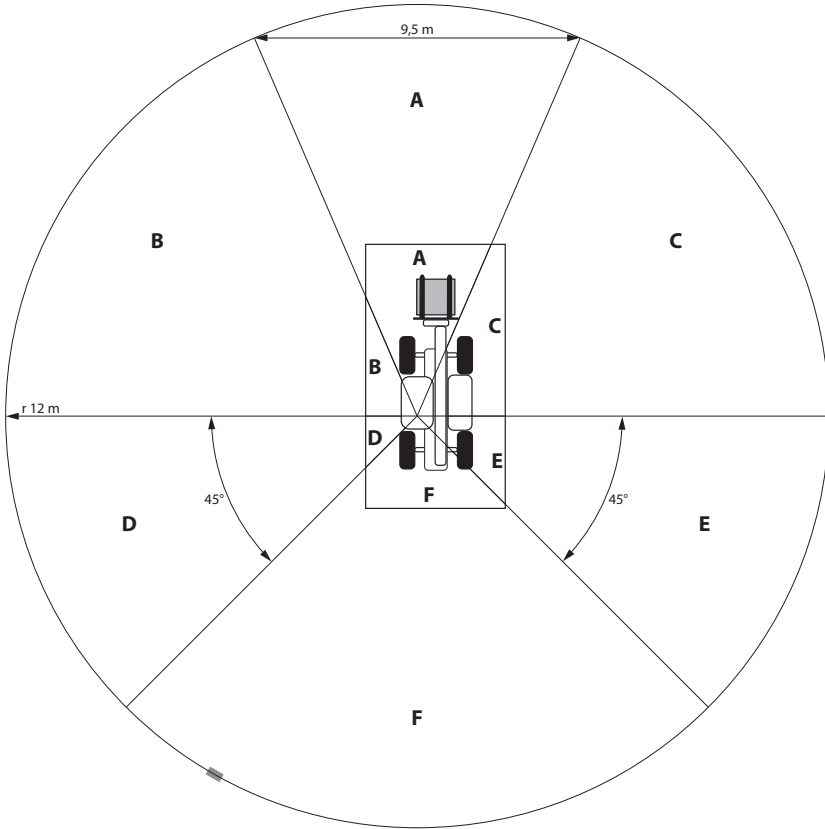

LOADING THE TRAILER (Test carried out in accordance with 6.3.4 of EN 15830)

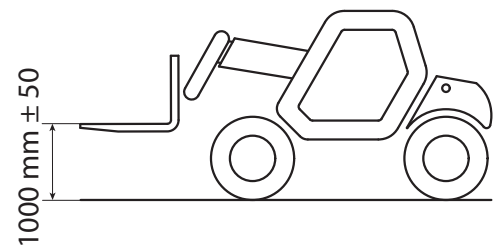
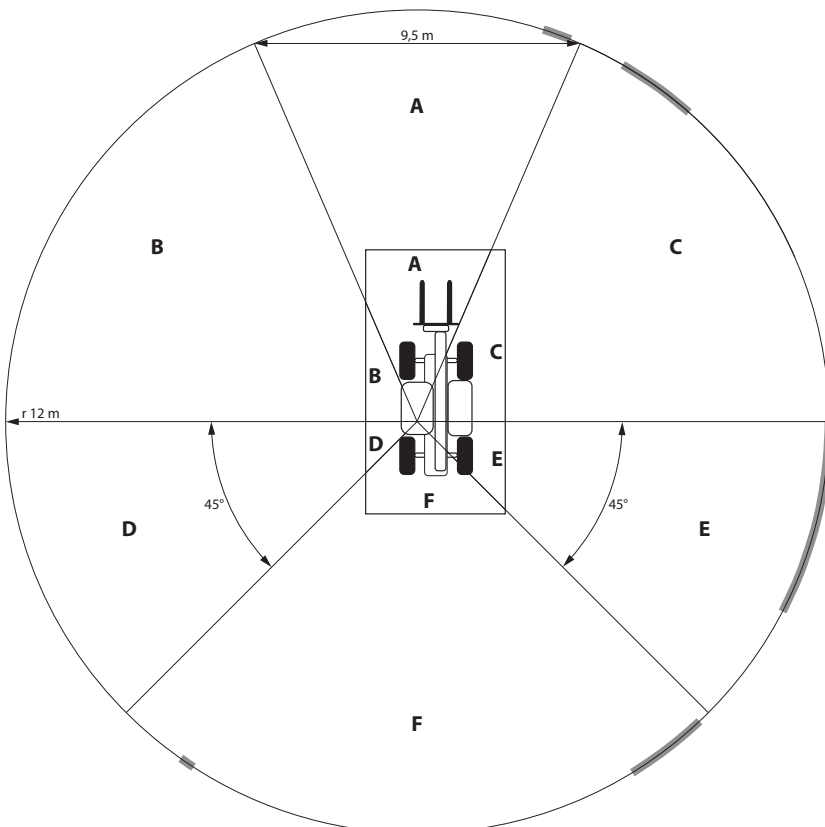

INSTRUMENTS AND CONTROLS

DESCRIPTION

N.B.: All the terms such as: RIGHT, LEFT, FRONT, REAR are as seen by an observer occupying the driver's seat and looking straight ahead.

1 - DRIVER'S CAB ACCESS	2-38
2 - SEAT BELT	2-38
3 - DRIVER'S SEAT	2-38
4 - IGNITION SWITCH	2-41
5 - EMERGENCY STOP	2-41
6 - BATTERY CUT-OFF	2-41
7 - BATTERY	2-41
8 - DASHBOARD "HARMONY"	2-42
9 - LONGITUDINAL STABILITY LIMITER AND WARNING DEVICE	2-46
10 - INFORMATION SCREEN CONTROL BUTTONS	2-48
11 - PUSH BUTTON PANEL	2-49
12 - SWITCHES	2-51
13 - ROOF WINDSHIELD WIPER SWITCH	2-51
14 - ROOF LIGHT	2-51
15 - ARMREST AND STORAGE	2-51
16 - DIAGNOSTIC PLUG	2-51
17 - FUSES AND RELAYS	2-52
18 - HANDLE FOR REAR WINDOW OPENING	2-54
19 - 12V SOCKET	2-54
20 - LIGHTING, HORN AND INDICATOR SWITCH	2-54
21 - FRONT AND REAR WINDSHIELD WIPER SWITCH	2-54
22 - FUNCTION FILES	2-54
23 - LEVEL INDICATOR	2-54
24 - HYDRAULIC BOOM CONTROLS	2-55
25 - ACCELERATOR PEDAL	2-55
26 - SERVICE BRAKE PEDAL AND TRANSMISSION CUT-OFF	2-55
27 - FORWARD/NEUTRAL/REVERSE SELECTOR	2-56
28 - STEERING SELECTION	2-56
29 - HEATER CONTROL	2-57
30 - AIR CONDITIONING CONTROLS (AIR CONDITIONING OPTION)	2-57
31 - DEMIST VENTS	2-57
32 - HEATING VENTS	2-57
33 - DOOR WINDOW OPENING HANDLE	2-58
34 - DOOR LOCK	2-58
35 - DOOR WINDOW RELEASE BUTTON	2-58
36 - DOCUMENT STORAGE NET	2-58
37 - FRONT HEADLIGHTS	2-58
38 - REAR LIGHTS	2-58
39 - ROTATING BEACON LIGHT	2-59
40 - BOOM SAFETY WEDGE	2-59
41 - FUEL TANK	2-59

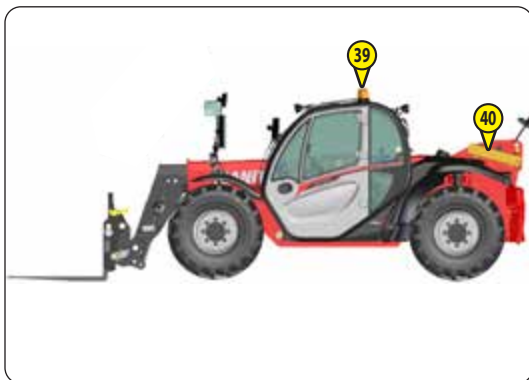
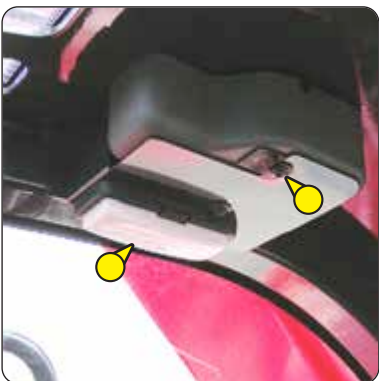

EMERGENCY BRAKE

SERVICE BRAKE

If the service brake is not working properly:

- Press down fully on the service brake pedal to immobilize the machine.
- Activate the hand-operated parking brake.



HAND-OPERATED PARKING BRAKE

⚠ IMPORTANT ⚠

Beware of sudden immobilization of the machine

In the event of immediate danger:

- Activate the hand-operated parking brake.



EMERGENCY EXIT

REAR WINDOW

Use the rear window as an emergency exit, if it is impossible to leave the cab by the door.



1 - DRIVER'S CAB ACCESS

Use the contact points 1 to get into or out of the driver's cab.

- Mounting at the front.
- Descending at the rear.



2 - SEAT BELT

⚠ IMPORTANT ⚠

*Under no circumstances must the lift truck be used if the seat belt is defective (fixing, locking, cuts, tears, etc.).
Immediately repair or replace the seat belt.*

- Sit correctly on the seat.
- Check that the seat belt is not twisted.
- Place the seat belt at hip level.
- Attach the seat belt and check that it locks.
- Adjust the seat belt to your body shape without compressing your pelvis and without excessive slack.



3 - DRIVER'S SEAT

For increased comfort, adjust the seat to your requirements and adopt the correct position in the driver's cab.

⚠ IMPORTANT ⚠

Under no circumstances must the seat be adjusted while the lift truck is moving.

MAINTENANCE

⚠ IMPORTANT ⚠

A moving backrest increases the risk of an accident!

Dirt may adversely affect the correct functioning of the seat. For this reason, make sure your seat is always clean.

- To clean or change the cushions, simply remove them from the seat frame.
- Avoid wetting the cushion fabric when cleaning it. Firstly check the resistance of the fabric on a small hidden area before using any fabric or plastic cleaner.



DRIVER'S SEAT (STANDARD)

DESIGNED FOR MAXIMUM COMFORT, THIS SEAT CAN BE ADJUSTED AS FOLLOWS.

WEIGHT ADJUSTMENT

Adjust the weight when the driver is sitting on the seat.

- Pull the weight adjustment lever 1 fully out.
- Move the weight adjustment lever 1 upwards to increase the weight or downwards to reduce it.
- There are ten possible positions between the min and max weights. Before each run, return the lever to the central position. The max. or min. position is indicated by a freely traveling lever.
- The driver's weight is correctly adjusted when the arrow is in the center of the indicator 2.
- After completing the weight adjustment, fully lower the lever 1.

N.B.: To avoid health problems, it is recommended that the weight setting is checked and adjusted before starting the lift truck.

LONGITUDINAL ADJUSTMENT

- Adjust the locking lever until you reach the position required. Once locked, you can no longer move the seat into another position.

⚠ IMPORTANT ⚠

Only operate the lever by its recessed section and do not grasp from below, at the risk of crushing the hand.

LUMBAR ADJUSTMENT

This increases the comfort of the seat and the driver's freedom of movement.

- Turn the handle to 1 to adjust the height and depth of the lumbar support of the upper part of the back-rest.
- Turn the handle to 2 to adjust the height and depth of the lumbar support of the lower part of the back-rest.

BACKREST ANGLE ADJUSTMENT

- Support the backrest, pull the lever and tilt the backrest to the desired position.

⚠ IMPORTANT ⚠

If you do not support the backrest when making adjustments, it swings forward.

MAINTENANCE

Dirt may adversely affect the correct functioning of the seat. For this reason, make sure your seat is always clean.

- The cushions do not need to be removed from the seat frame for cleaning.

⚠ IMPORTANT ⚠

Accident risks are increased when the back-rest tilts.

First check the resistance of the fabric on a small concealed area before using any fabric and plastic cleaner.

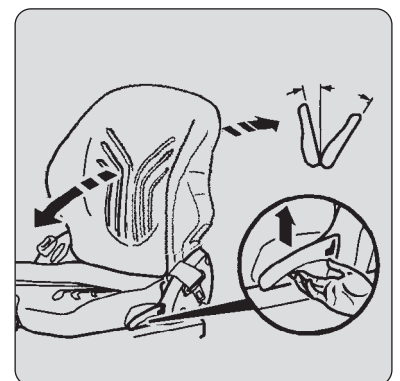
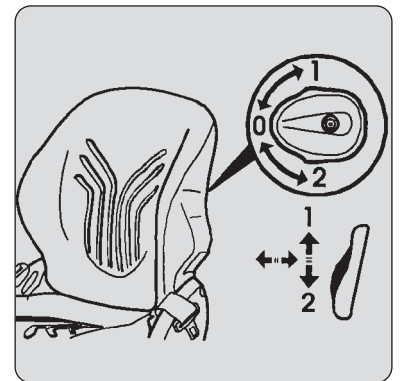
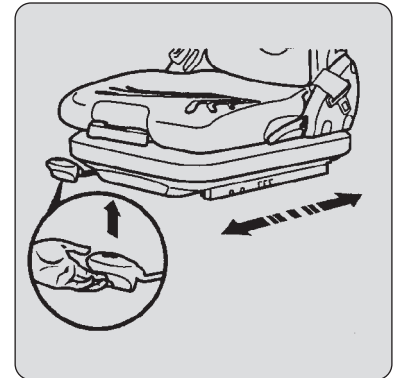
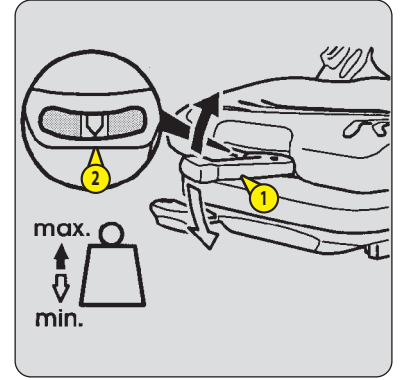

DRIVER'S SEAT (OPTION)

WEIGHT ADJUSTMENT

- Sit on the seat.
- Turn button 1 to adjust according to the operator's weight.

LONGITUDINAL ADJUSTMENT

- Engage the locking lever 2 in the desired position.
- Once locked, you can no longer move the seat into another position.

BACKREST ANGLE ADJUSTMENT

- Support the backrest, pull the lever 3 and tilt the backrest to the desired position.

LUMBAR ADJUSTMENT

- Pull handle 4 to adjust the lumbar support.



4 - IGNITION SWITCH

This key switch has 5 positions:

- P - Not used.
- O - Ignition cut-off and engine stop.
- I - Ignition + preheat.
- II - Not used.
- III - Start-up and return to I position as soon as the key is released.



5 - EMERGENCY STOP

In the event of danger, it enables the engine to be shut down, thereby cutting-off all hydraulic movements.

⚠ IMPORTANT ⚠

Be ready for hydraulic movements suddenly stopping when you press this button.

If possible stop the lift truck before using the emergency stop button.

- Turn switch to disable.



6 - BATTERY CUT-OFF

For quickly disconnecting the battery when working on the electric circuit or when soldering, for example.

⚠ IMPORTANT ⚠

Operate the battery cut-off for a minimum of 30 seconds after having switched off the ignition with the ignition key.



7 - BATTERY



8 - DASHBOARD "HARMONY"

INSTRUMENTS AND INDICATORS

A - TACHOMETER

B - ENGINE WATER TEMPERATURE

If the indicator lamp  comes on when the lift truck is running, this means that the coolant temperature is high. Leave the engine idling to lower the water temperature. If the fault persists, turn the engine off and investigate the cooling circuit for the cause of the malfunction.

C - FUEL LEVEL

Indicator lamp , indicates that you are in reserve and that your running time is limited.

D - NOT USED



BATTERY LOAD FAULT INDICATOR

If the indicator and the buzzer come on when the lift truck is running, stop the engine immediately and determine the cause (electric circuit, alternator belt, alternator, etc.).



STEERING SYSTEM OIL PRESSURE FAULT INDICATOR

If the indicator comes on when the lift truck is running, stop the engine immediately and determine the cause (possible leak, etc.).



WATER IN FUEL PRE-FILTER FAULT INDICATOR

The indicator light will come on when water is detected in the fuel pre-filter. Stop the lift truck and carry out the necessary repairs.



BRAKING OIL LEVEL WARNING INDICATOR LAMP

If the indicator lamp and buzzer come on when the lift truck is running, stop the engine immediately and determine the cause (brake fluid level, possible leak, etc.). If the brake fluid level is abnormal, consult your dealer.



ENGINE OIL PRESSURE FAULT INDICATOR

If the indicator light comes on when the lift truck is in operation, stop the engine immediately and look for the cause (oil level in engine crankcase).

N.B.: After starting the engine, the indicator lamp remains on for a few seconds then goes out when the correct engine oil pressure is reached. The full engine power is then available.



ENGINE PREHEATING INDICATOR

Preheating is necessary. When the lift truck is switched on, the indicator lamp comes on for 2 seconds and goes off as soon as preheat is ended. Start the lift truck's engine.



NOT USED



NOT USED

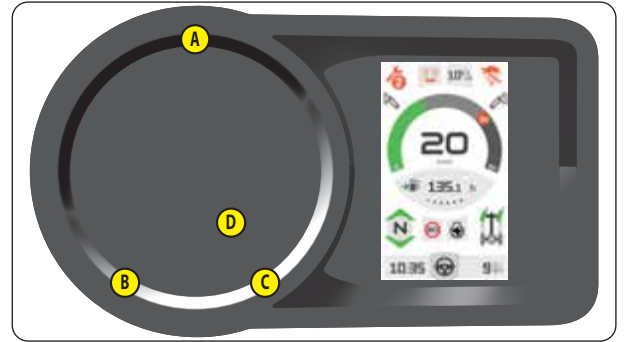



HYDRAULIC RETURN FILTER CLOGGING FAULT INDICATOR

The indicator light and buzzer come on when the hydraulic return oil filter cartridge is clogged. Stop the engine and carry out the necessary repairs (↖ 3 - MAINTENANCE: FILTER CARTRIDGES AND BELTS).



ENGINE COOLANT LEVEL FAULT INDICATOR

If the indicator light and buzzer come on when the lift truck is in operation, stop the engine immediately and determine the cause (coolant level, possible leak, radiator, etc.).



ENGINE STOPPED FAULT INDICATOR

If the indicator lights up or flashes when the lift truck is in operation, stop the engine immediately and consult your dealer.



NOT USED



ENGINE FAULT INDICATOR

If the indicator light comes on or flashes while the lift truck is in operation, a diagnostic fault has been detected. The lift truck will operate in reduced mode. Consult your dealer as soon as possible.



FAULT INDICATOR "SCR" (selective catalytic reduction)

The indicator comes on if a system efficiency problem is detected.

 +  + audible signal	-Consult your dealer as soon as possible.
--	---



CRYSTALLIZATION OR SULFURIZATION LEVEL INDICATOR

If the indicator lamp flashes while the lift truck is in operation, perform a "STATIONARY LIFT TRUCK" EXHAUST REGENERATION (↖ 3 - MAINTENANCE: OCCASIONAL MAINTENANCE).



AUTOMATIC EXHAUST REGENERATION DEACTIVATED INDICATOR LAMP

The indicator lamp comes on when the lift truck is running to indicate that the automatic exhaust regeneration is disabled (↖ SWITCHES).



HIGH EXHAUST GAS TEMPERATURE INDICATOR LIGHT

The indicator lamp comes on while the lift truck is operating to indicate a high exhaust gas temperature. You can continue to use the lift truck (↖ SWITCHES).



EXHAUST LINE FAULT INDICATOR LAMP

If the indicator lights up or flashes when the lift truck is in operation, stop the engine immediately and consult your dealer.

INFORMATION SCREEN

 **HIGH BEAM HEADLIGHTS INDICATOR**

 **LOW BEAM HEADLIGHTS INDICATOR**

 **TURN SIGNAL INDICATOR**

 **PARKING BRAKE LAMP**

 **BEACON INDICATOR**

 **MAINTENANCE REQUIRED**

 **MAINTENANCE OVERDUE**

 **MAINTENANCE OVERDUE + NUMBER OF ERROR CODES**

 **BOOM ANGLE**

 **HYDRAULIC MOVEMENT NEUTRALIZATION**

 **DISABLING "AGGRAVATING" HYDRAULIC MOVEMENT CUT-OFF**

 **NOT USED**

 **GEAR RATIO**

 **BLOCKING REAR AXLE OSCILLATION**

- Blocking of the rear axle oscillation is automatically managed by the machine electronics from a 6°/10.5% slope and 45° boom angle.
- The rear axle oscillation locking cylinder is activated to guarantee better machine stability.
- A blue pop-up appears on the screen to warn the user that the machine is immobilized. Only telescopic boom retraction and attachment crowd movements are possible to move the machine forward or back.

 **WHEEL STEERING INDICATOR**

 **CLOCK**

 **DRIVING MODE**

 **WORK MODE**

 **EXTERNAL TEMPERATURE**





HOUR METER

- This screen is displayed for a few seconds when the ignition is switched on.



SPEEDOMETER

- This screen is displayed in driving mode.



HYDRAULIC FLOW RATE ADJUSTMENT

- This screen is displayed in work mode.

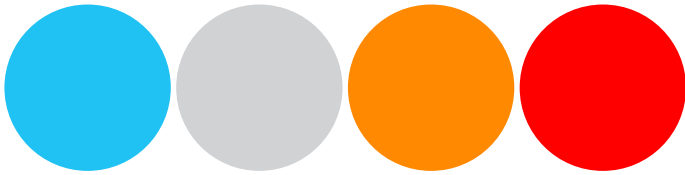







POP UP

- Blue POP UP: information message.
- Grey POP UP: operating message.
- Orange POP UP: warning message.
- Red POP UP: fault message, consult your dealer.



INFORMATION SCREEN

- Hold down the  or  button to choose.

-  Total hour meter.
-  Partial hour meter.
-  Instantaneous fuel consumption.
-  Average fuel consumption.
-  Fuel autonomy.
-  Tachometer.

9 - LONGITUDINAL STABILITY LIMITER AND WARNING DEVICE

⚠ IMPORTANT ⚠

The operator must respect the lift truck's load chart, and the operating mode according to the attachment.

This device warns the operator of the forklift truck's longitudinal stability limits. However, lateral stability can reduce the load chart in the upper part, and this reduction is not detected by the device.

Depending on the type of work required, the operating modes of the longitudinal stability limiter and warning device allow the operator to operate the lift truck in complete safety.

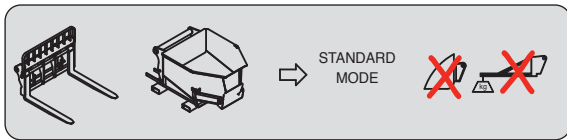
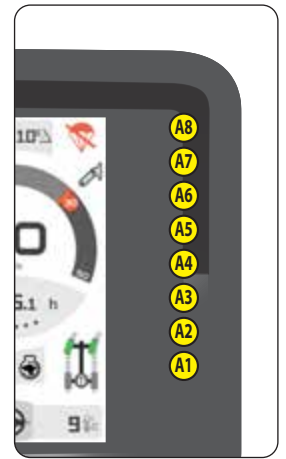

"HANDLING" MODE

USE ON FORKS

- By default, the device is in "HANDLING MODE" each time the lift truck is started.
- Protection against tilting forward during aggravating movements is guaranteed, except when the telescope is retracted.

STATUS OF THE DEVICE			
HALTED	SLOW SPEED 1 to 5 km/h	SPEED > 5 km/h	TELESCOPE(S) RETRACTED
A4-A5 : Very slow intermittent sound alarm. A6 : Slow intermittent sound alarm. A7 : Fast intermittent audible alarm. A8 : Very fast intermittent audible alarm.	A7 : Fast intermittent audible alarm. A8 : Very fast intermittent audible alarm.	-No sound alarm.	-No sound alarm. -Indicator light on.

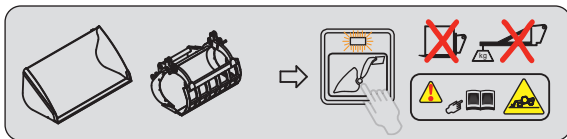

"BUCKET" MODE

USE WITH BUCKET

- Place the lift truck in the transport position.
- Press the button, "BUCKET" MODE is confirmed by an audible signal and by the light coming on.
- Press this button again or switch off the ignition with the ignition key to return to "HANDLING" MODE.
- Protection against tilting forward during aggravating movements is guaranteed, except when the telescope is retracted.

STATUS OF THE DEVICE			
HALTED	SLOW SPEED 1 to 5 km/h	SPEED > 5 km/h	TELESCOPE(S) RETRACTED
-The "BUCKET" mode deactivates after a few seconds if the lift truck remains stationary.	A6 : An audible signal upon passing into the red zone. -The hydraulic movements are adapted.	No sound alarm. -The hydraulic movements are adapted.	-No sound alarm. -Indicator light on.

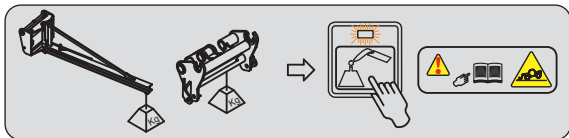

"SUSPENDED LOAD" MODE

USE WITH LIFTING DEVICE (offering a higher margin of safety)

- Place the lift truck in the transport position.
- Press the  button; the "SUSPENDED LOAD" MODE is confirmed by an audible signal and by the indicator lamp coming on. Hydraulic tilting movements are neutralized, as well as the lifting movement when the longitudinal stability limit is reached (indicator lamp A8 on).
- Press this button again or switch off the ignition with the ignition key to return to "HANDLING" MODE.
- Protection against tilting forward during aggravating movements is guaranteed, except when the telescope is retracted.

STATUS OF THE DEVICE			
HALTED	SLOW SPEED 1 to 5 km/h	SPEED > 5 km/h	TELESCOPE(S) RETRACTED
	A4-A5 : Very slow intermittent sound alarm. A6 : Slow intermittent sound alarm. A7 : Fast intermittent audible alarm. A8 : Very fast intermittent audible alarm.		-No sound alarm. -Indicator light  on.

A - VISUAL ALARMS

- A1 - A2 - A3: There is a significant reserve of longitudinal stability.
- A4 - A5: The lift truck is nearing the limit of longitudinal stability. Maneuver with care.
- A6: The lift truck is close to the longitudinal stability limit. Maneuver with care.
- A7: The lift truck is very close to the longitudinal stability limit. Manoeuvre with extreme caution.
- A8: The lift truck is at the authorized limit of longitudinal stability.

B - HYDRAULIC MOVEMENT CUT-OFF

"HANDLING" MODE

- A8: All "AGGRAVATING" hydraulic movements are cut off. Only perform de-aggravating hydraulic movements in the following order: retract and raise the boom.

"BUCKET" MODE

- A8: The boom lowering and extension movements are cut off; the other movements remain available.

"SUSPENDED LOAD" MODE



- A8: All "AGGRAVATING" and boom raising hydraulic movements are cut off. Only the boom retraction hydraulic movement is available.

C - DISABLING "AGGRAVATING" HYDRAULIC MOVEMENT CUT-OFF



Remain very vigilant during this operation. The only information available to the operator is the lift truck's dynamic stability.

In certain cases, in order to get out of a difficult situation, the operator can bypass this safety device. The  button temporarily disables the cutting-off of "AGGRAVATING" hydraulic movements.

- Hold down the  button, the indicator lamp will light (60 second time delay), and the  pictogram will appear on the information screen. Simultaneously perform the necessary AGGRAVATING hydraulic movement with extreme care.

D - STRAIN GAGE



Disassembly or calibration of the strain gage is prohibited, this must only be done by specially trained personnel, consult your dealer.





10 - INFORMATION SCREEN CONTROL BUTTONS

N.B.: The content of the "PREFERENCES" and "INFORMATION" menus varies according to the lift truck equipment.





INFORMATION MENU

- Press the button to display the "INFORMATION" menu
- Press the button  to select from the menus and sub-menus.
- Press knob  to confirm.

REPAIR	>	FAULTS
MAINTENANCE	>	MAINTENANCE RESET
GENERAL	>	IDENTIFICATION
	>	SOFTWARE VERSION
HYDRAULIC	>	OIL LEVEL

PREFERENCES MENU

- Press the button to display the "PREFERENCES" menu
- Press the button  to select from the menus and sub-menus.
- Press knob  to confirm.

SYSTEM	>	DATE AND TIME		
	>	LANGUAGES		
	>	UNITS		
	>	SCREEN		
	>	POP UPS		
	>	DIGICODE (OPTION)		
	>	CAMERAS (OPTION)		
	>	CUSTOMER CODE)		
	>	CONFIGURATION (customer or expert code)	>	PARTIAL HOUR METER RESET
		>	MAINTENANCE HOUR METER RESET	
TRANSMISSION	>	ECO MODE (OPTION)		
	>	MANUAL ACCELERATOR (OPTION)		
	>	TRAILER BRAKE TEST (OPTION)		
HYDRAULIC	>	STABILITY REBALANCING		
	>	LSU HYDRAULICS		
	>	STABILITY TEST		
	>	EASY CONNECT SYSTEM (OPTION)		
	>	JSM AUTOPOWER		
	>	CONFIGURATION (customer or expert code)	>	OVERRIDE
			>	FORCED OPERATION NO DRIVER
ENGINE	>	ECO STOP (OPTION)		
	>	FAN DRIVE FAN REVERSAL		
	>	REGENERATION		
EXPERT (expert code)	>	STABILITY CALIBRATION		
	>	BOOM ANGLE CALIBRATION		
	>	AXLE BLOCKING TEST		
	>	PEDAL CALIBRATION INCHING		
	>	CARRIAGE ANGLE CALIBRATION		
	>	DISTRIBUTOR CALIBRATION		
	>	INCLINOMETER CALIBRATION		
	>	EXPERT CODE		

BACK

- Press the button to return to the previous stage.

CONFIRMATION

- Press the button to move on to the next step.

MOVE UP

- Press the button to change menu.

MOVE DOWN

- Press the button to change menu.

11 - PUSH BUTTON PANEL

BUTTON FUNCTIONS

- Red button: Safety.
- Orange button: Transmission / Engine.
- Blue button: Hydraulics.
- Black button: Other.

BUTTON DIAGNOSTICS

- If all buttons are unlit, there is a power supply problem. Contact your dealer.
- If all buttons are flashing, there is a connection problem. Contact your dealer.



HYDRAULIC MOVEMENT NEUTRALIZATION

When driving on the road, it is highly recommended (mandatory in Germany) that you disconnect all hydraulic movement. The indicator lamp and  image on the information screen indicate use.



ROTATING BEACON LIGHT

The indicator lamp indicates it is in use.



ENGINE SPEED MEMORIZATION (OPTION)

 DESCRIPTION AND USE OF THE OPTIONS



SPEED LIMITER (OPTION)

 DESCRIPTION AND USE OF THE OPTIONS



AUTOMATIC PARKING BRAKE

The function is used to engage the parking brake when the lift truck is stopped and to release the parking brake when the lift truck movement conditions are met.

- Press the  button to activate. The indicator light will come on, showing that it is in use.
- Press the button again to deactivate.



"MANUAL MODE" AUTOMATIC PARKING BRAKE

- Press the  button to activate. The indicator light will come on, showing that it is in use.
- Press the button again to deactivate.



"BUCKET" MODE

 LONGITUDINAL STABILITY LIMITER AND WARNING DEVICE



"SUSPENDED LOAD" MODE

 LONGITUDINAL STABILITY LIMITER AND WARNING DEVICE



DISABLING "AGGRAVATING" HYDRAULIC MOVEMENT CUT-OFF

◀ LONGITUDINAL STABILITY LIMITER AND WARNING DEVICE



NOT USED



TILT CIRCUIT LOCKING

- Press the button to shut off the tilt circuit hydraulic movements. The indicator lamp indicates it is in use.



ATTACHMENT CIRCUIT LOCKING

- Press the button to shut off the attachment circuit hydraulic movements. The indicator lamp indicates it is in use.



ATTACHMENT CIRCUIT FLOW RATE LIMITER (OPTION)

◀ DESCRIPTION AND USE OF THE OPTIONS



ATTACHMENT CIRCUIT MANUAL OVERRIDE (OPTION)

◀ DESCRIPTION AND USE OF THE OPTIONS



"STATIONARY LIFT TRUCK" EXHAUST REGENERATION

◀ 3 - MAINTENANCE: OCCASIONAL MAINTENANCE



AUTOMATIC EXHAUST REGENERATION DEACTIVATION

⚠ IMPORTANT ⚠

Deactivation of the automatic exhaust regeneration is a function that should only be used when necessary (in confined or unventilated spaces, etc.).

By default, the automatic exhaust regeneration is activated each time the lift truck is started.

- To deactivate the automatic exhaust regeneration, hold down the switch. The indicator lamp lights up and an audible signal confirms deactivation.
- To reactivate the automatic exhaust regeneration, hold down the switch again. The indicator lamp goes out to confirm reactivation.

EXHAUST REGENERATION MANAGEMENT			
SIGNALS	ACTIONS		
+ 1 short sound alarm. Moderate soot level.	Indicator lamp comes on. It is preferable to wait for the automatic regeneration process to finish before removing the ignition key.	Or	Activate "stationary lift truck" exhaust regeneration (◀ 3 - MAINTENANCE: OCCASIONAL MAINTENANCE).
+ + 1 short sound alarm. Moderate soot level, automatic regeneration disabled.	Enable automatic regeneration at the earliest possible time.	Or	Activate "stationary lift truck" exhaust regeneration (◀ 3 - MAINTENANCE: OCCASIONAL MAINTENANCE).
+ + permanent sound alarm. High soot level.	Engine speed limited to 1,200 rpm, only a "stationary lift truck" regeneration must be performed (◀ 3 - MAINTENANCE: OCCASIONAL MAINTENANCE).		
+ + + permanent sound alarm. High soot level, automatic regeneration disabled.			
+ + STOP + 1 short sound alarm. Very high soot level, particle filter clogged.	<i>If the lift truck is under-performing, stop the lift truck and contact your dealer.</i>		



STOP&START (OPTION)

◀ DESCRIPTION AND USE OF THE OPTIONS









OPTION



12 - SWITCHES

N.B.: The location of the switches may vary depending on the options.

-  **HAZARD WARNING LIGHTS**
 -  **REAR FOG LIGHT (OPTION)**
 -  **ROTATING BEACON LIGHT**
 -  **FRONT AND REAR WORKLIGHTS (OPTION)**
 -  **REAR WINDOW DEFROSTER (OPTION)**
 -  **BOOM ELECTRICAL PREDISPOSITION (OPTION)**
- < DESCRIPTION AND USE OF THE OPTIONS



13 - ROOF WINDSHIELD WIPER SWITCH

14 - ROOF LIGHT



15 - ARMREST AND STORAGE

- Lift the armrest 1 to access the storage.



16 - DIAGNOSTIC PLUG

- Remove the access panel to access the plugs.



17 - FUSES AND RELAYS

A sticker on the inside of the access hatch provides a quick view of the use of the electric plate's components described below.

- Remove access panel 1 to gain access to the fuses and relays. Replace a blown fuse with a new fuse of the same quality and rating. Never use a repaired fuse.

IN THE CAB

F1	5A	Screen/navigator wake-up.
F2	5A	Water in fuel sensor. Alternator excitation. ECM wake-up.
F3	5A	Anti-theft device predisposition. Diagnostics plug.
F4	10A	JSM joystick. "Hydraulics" electronic control unit.
F5	15A	12 V plug. Car radio (OPTION).
F6	2A	Boom angle sensors.
F7	20A	"Hydraulics" electronic control unit permanent (+) power supply. Electrovalve power supply. Permanent (+) power supply.
F8	7,5A	Boom head solenoid valve (OPTION).
F9	10A	Brake light relay power supply. Reversing light relay power supply. Audible reversing alarm relay power supply.
F10	2A	Wheel alignment.
F11	10A	Flashing light unit. K8
F12	5A	Rear fog lights.
F13	10A	Working lights on boom switch (OPTION).
F14	7,5A	Rotating beacon.
F15	10A	Rear window defroster (OPTION).
F16	7,5A	Rear axle locking electrovalve power supply.
F17	15A	Rear windshield wiper and windshield washer. Roof windshield wiper.
F18	15A	Front windshield wiper and windshield washer.
F19	30A	Power supply F27-F28-F29-F30.
F20	20A	Heating.
F21	5A	Left parking lights.
F22	5A	Right parking lights.
F23	15A	Dipped beam headlights.
F24	15A	Main beam headlights.
F25	7,5A	Right turn signals.
F26	7,5A	Left turn signals.
F27	7,5A	Boom head electric power socket (OPTION). Camera (OPTION).
F28	5A	Telescope speed sensor. Inclinometer.
F29	10A	Pneumatic seat (OPTION).
F30	20A	Front and rear worklights (OPTION).
		Sidelights.
	25A	Front work lights (OPTION). Rear work lights (OPTION).
F31	20A	Lighting switch (dipped beam headlights, main beam, sidelights).
F32	15A	Hazard warning lights.
F33	5A	Diagnostics plug. Anti-theft device predisposition.
F34	7,5A	Warning device.
F35	10A	Car radio (OPTION).
F36	7,5A	Main ECU permanent (+) power supply "Hydraulics" electronic control unit power supply.
F37	10A	Rear windshield wiper (+) permanent.
F38	10A	Front windshield wiper (+) permanent.
F39	3A	Roof light permanent (+) power supply. Screen permanent (+) power supply.
F40	25A	Air conditioning electric fan (OPTION). Air conditioning compressor (OPTION).

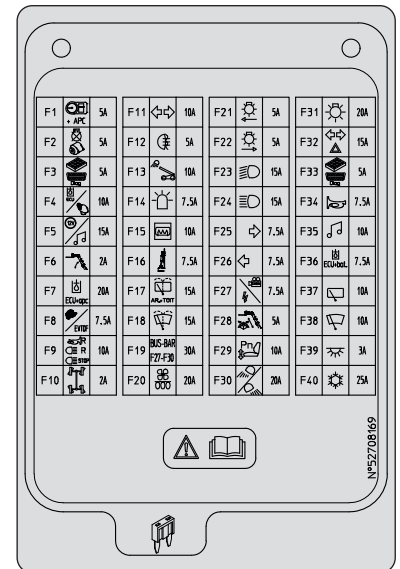

F71	2A	Control instrument module power supply.
F72		Unused.
F73	3A	Telescope retraction + seat belt contact speed limitation.
F74	2A	Inclinometer power supply.

K1		Free
K2		Reversing lights. Reversing sound alarm.
K3		Brake lights.
K4		Working lights on boom (OPTION).
K5		Front windshield wiper speed 1 intermittence relay.
K6		Rotating beacon light power supply
K7		Heating.
K8		Flashing light unit.
K9		Flashing light unit power supply.
K10		Hazard warning lights.

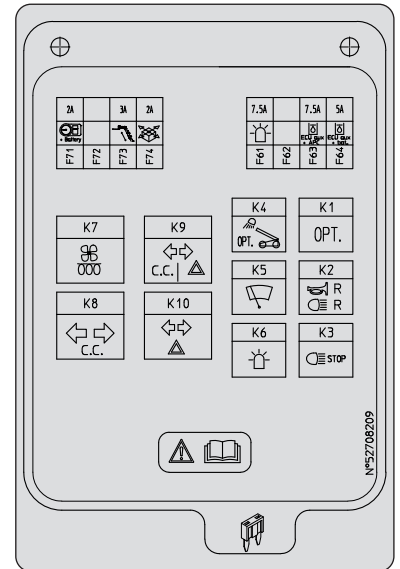

IN THE ENGINE COMPARTMENT

- Open the engine hood, remove cover 1 to gain access to the fuses and relays. Replace a blown fuse with a new fuse of the same quality and rating. Never use a repaired fuse.

F41	20A	Engine ECU power supply.
F42	60A	Ignition switch.
F43	80A	Alternator.
F44	50A	Power supply for fuses in the cab.
F45	30A	Starter relay power supply.
F46	40A	Engine preheat. Fuel preheater (OPTION).
F51	5A	Air flow sensor. Engine EGR valve.
F52	3A	Dashboard power supply.
F53	5A	Start relay control K22. Engine ECU information.
F54	5A	Water in fuel sensor power supply.
F55	5A	Engine ECU control power supply.

K20		Engine preheat.
K21		Engine ECU power supply.
K22		Starter control.

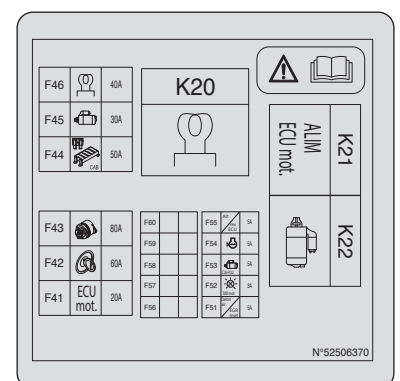
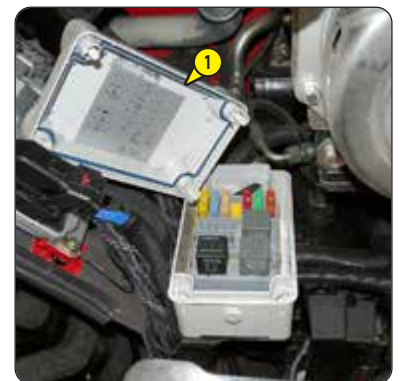

18 - HANDLE FOR REAR WINDOW OPENING

19 - 12V SOCKET

For 12 V appliance and max. amperage 10A.



20 - LIGHTING, HORN AND INDICATOR SWITCH

The switch controls the visual and sound alarms.

- A - The lights are off, the indicator lights do not flash.
- B - The right hand indicator lights flash.
- C - The left hand indicator lights flash.
- D - Sidelights and rear lights on.
- E - The dipped headlights and the rear lights are on.
- F - The main beam headlights and the rear lights are on.
- G - Headlight signaling.

Pressing the end of the switch sounds the horn.

N.B.: Positions D - E - F - G can be used without switching on the ignition.

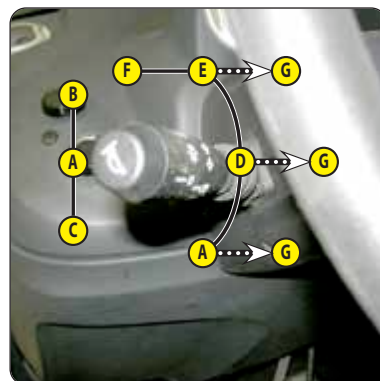

21 - FRONT AND REAR WINDSHIELD WIPER SWITCH

FRONT WINDSHIELD WIPER

- A - Front windshield wiper stop.
- B - Front windshield wiper low speed.
- C - Front windshield wiper high speed.
- D - Front windshield wiper intermittent.
- E - Front windshield washer by pressing.

REAR WINDSHIELD WIPER

- F - Rear windshield wiper stop.
- G - Rear windshield wiper.
- H - Rear windshield washer by pressing.

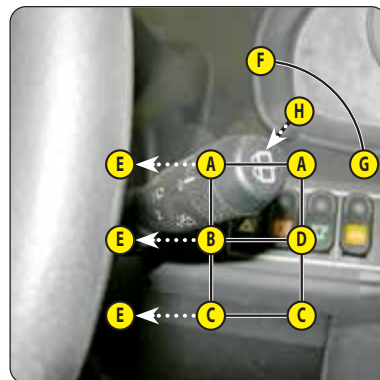

22 - FUNCTION FILES

These files contain, among other things, the description of the hydraulic controls and the load charts for the attachments used on the lift truck.



23 - LEVEL INDICATOR

A - SPIRIT LEVEL

Enables the operator to check that the lift truck is in the horizontal position.

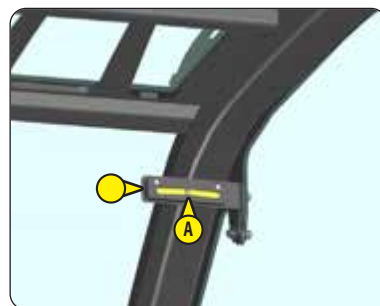

24 - HYDRAULIC BOOM CONTROLS

⚠ IMPORTANT ⚠

Do not try to modify the hydraulic pressure of the system. If it malfunctions contact your dealer. ANY MODIFICATION INVALIDATES THE WARRANTY AND YOU WILL BE CRIMINALLY LIABLE IN THE EVENT OF AN ACCIDENT.

Use the hydraulic controls gently without jerking, to avoid incidents caused by shaking the lift truck.

N.B.: If necessary, operate the steering to reset the hydraulic control steering accumulator.

N.B.: When driving on the road, it is highly recommended (mandatory in Germany) that you disconnect all hydraulic movement (⇐ PUSH BUTTON PANEL).

HYDRAULIC CONTROLS ACTIVATION

This safety device prevents accidental operation of the hydraulic lifting, tilting, telescoping and attachment controls.

- Place your hand on the lever, activate the hydraulic controls by contact on sensor 1 and perform the hydraulic movement.
- Hydraulic controls activation is maintained on a timer while the lift truck is being used.
- If necessary, reactivate the hydraulic controls.

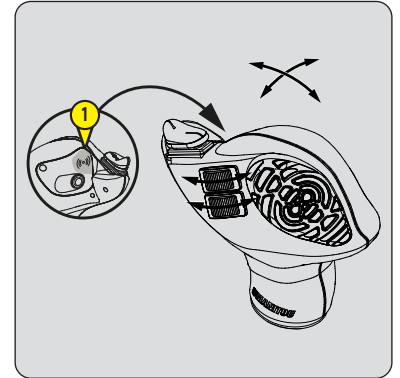

A1 - LIFTING

A2 - LOWERING

B1 - CROWD

B2 - DUMP

C1 - TELESCOPIC BOOM EXTENSION

Note: On triplex booms, when completely retracting the telescopes, keep operating the control until all the telescopes are fully retracted.

C2 - TELESCOPIC BOOM RETRACTION

D1 - ATTACHMENT (OPTION)

D2 - ATTACHMENT (OPTION)

E - BOOM HEAD SOLENOID VALVE (OPTION)

⇐ DESCRIPTION AND USE OF THE OPTIONS

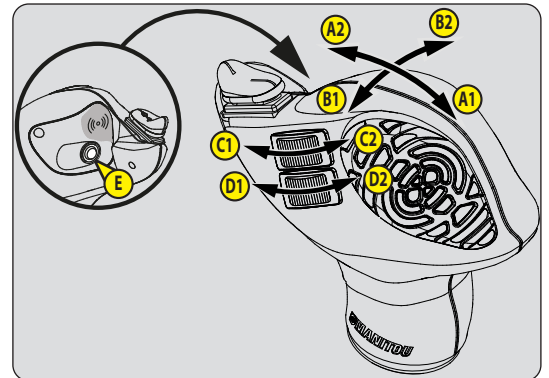

25 - ACCELERATOR PEDAL



26 - SERVICE BRAKE PEDAL AND TRANSMISSION CUT-OFF

The pedal acts on the front wheels by means of a hydraulic brake system enabling the lift truck to be slowed down and stopped. This allows the transmission to be gradually cut off during the free travel range to enable a gradual approach (delicate handling) with full engine power.



27 - FORWARD/NEUTRAL/REVERSE SELECTOR

When changing the direction of travel, the lift truck should be traveling at slow speed and not accelerating.

FORWARD: Push the switch forward (position A).

REVERSE: Push the switch backward (position B). A reversing light and reversing sound alarm indicate that the lift truck is traveling in reverse.

NEUTRAL: The switch must be in the neutral position (position C) to start the lift truck.

N.B.: Backup alarm (OPTIONAL or STANDARD).

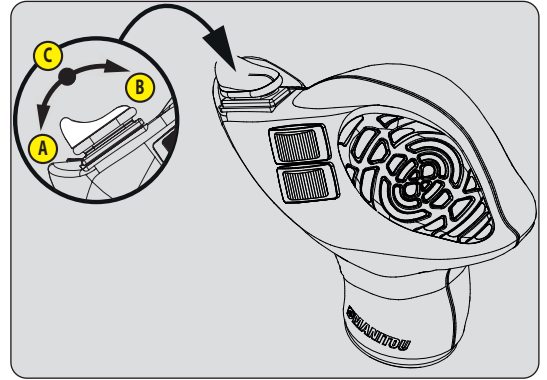

SAFETY FOR MOVING THE LIFT TRUCK

The operator must observe the following sequence to move the truck forward or backward:

- 1 - sit down correctly in the driver's seat,
- 2 - release the hand brake,
- 3 - engage forward or reverse gear.

N.B.: The alternate display of the forward or reverse section arrow  on the information screen requires the selector to be set to neutral.

To stop the forklift truck without switching off the ignition, the following sequence must be followed:

- 1 - set the forward/reverse selector to neutral,
- 2 - apply the parking brake,
- 3 - get out of the lift truck.

N.B.: A discontinuous audible signal and a message on the screen will inform the driver if he has left the driver's cab without applying the parking brake.

28 - STEERING SELECTION

A - GREEN WHEEL ALIGNMENT INDICATOR LAMPS

⚠ IMPORTANT ⚠

*Before selecting one of the three steering possibilities, align the 4 wheels in relation to the lift truck axis.
Never change the steering mode whilst driving.*



The green indicator lights on the information screen  come on to indicate the alignment of the wheels relative to the lift truck.

B - STEERING SELECTION LEVER

- B1 - Front steering wheels (road mode).
- B2 - Front and rear steering wheels in opposite directions (short steering).
- B3 - Front and rear steering wheels in the same direction (crab steering).

WHEEL ALIGNMENT CONTROL

⚠ IMPORTANT ⚠

*Before traveling on a public road, it is necessary to check the rear wheel alignment and to travel on front drive wheels.
Checking the rear wheel alignment must be performed regularly using the green indicator lamps when the forklift truck is in motion.*

In case of technical faults, consult your dealer.

- Place the steering selection lever B in position B2 (short turning circle).
- Turn the steering wheel and bring the rear wheels into alignment until the A2 indicator lamp comes on.
- Place the steering selection lever B in position B1 (road traffic).
- Turn the steering wheel and align the front wheels until lamp A1 lights up.



29 - HEATER CONTROL

A - FAN CONTROL

This 3-speed control allows the air to be ventilated through the air vents.

B - TEMPERATURE CONTROL

Adjusts the temperature inside the cab.

- B1 - The fan pumps in the air at ambient temperature.
- B2 - The fan pumps in warm air.

The intermediate positions allow the temperature to be adjusted.



30 - AIR CONDITIONING CONTROLS (AIR CONDITIONING OPTION)

⚠ IMPORTANT ⚠

The air conditioning only works if the lift truck has been started.

When using your air conditioning, it is essential to work with the cab closed.

In winter: So as to ensure that the air conditioning unit is correctly operated and completely efficient, start up the compressor once a week, even for a short period of time, in order to lubricate the internal seals.

In cold weather: Warm the engine before switching on the compressor, in order to allow the coolant that has collected in the liquid state at the lowest point of the compressor's circuit to turn into gas under the effect of the heat given off by the engine, as the compressor is liable to be damaged by coolant in the liquid state.

If it seems to you that the air conditioning is not working properly, have it inspected by your dealer.

Never try to repair any faults yourself.

A - FAN CONTROL

This 3-speed control allows the air to be ventilated through the air vents.

B - TEMPERATURE CONTROL

Adjusts the temperature inside the cab.

- B1 - The fan pumps in cold air.
- B2 - The fan pumps in warm air.

The intermediate positions allow the temperature to be adjusted.

C - AIR CONDITIONING CONTROL

This control with a pilot light allows the air conditioning unit to be switched on.

HEATING MODE

- The controls must be adjusted in the following way:
 - C - Control with pilot light off.
 - B - At the desired temperature.
 - A - At the desired speed: 1, 2 or 3.

AIR CONDITIONING MODE

- The controls must be adjusted in the following way:
 - C - Control with indicator lamp on.
 - B - At the desired temperature.
 - A - At the desired speed: 1, 2 or 3.

DEFROST MODE

- The controls must be adjusted in the following way:
 - C - Control with indicator lamp on.
 - B - At the desired temperature.
 - A - At speed 2 or 3.
- For optimum effectiveness, close the heating vents.



31 - DEMIST VENTS

These vents allow the windshield and side windows to be demisted. For optimum effectiveness, close the heating vents.

32 - HEATING VENTS

These swiveling heating vents, which can be shut off, allow you to direct and adjust the flow inside the cab.

33 - DOOR WINDOW OPENING HANDLE

34 - DOOR LOCK

Two keys are provided with the lift truck to enable the cab to be locked.

35 - DOOR WINDOW RELEASE BUTTON

36 - DOCUMENT STORAGE NET

Make sure that the operator's manual is in the right place, i.e. in the document holder net.

N.B.: An OPTIONAL waterproof document-holder is available.

37 - FRONT HEADLIGHTS

- A - Front left-hand indicator light.
- B - Front left-hand dipped headlight.
- C - Front left-hand headlight.
- D - Front left-hand sidelight.
- E - Front right-hand indicator light.
- F - Front right-hand low beam headlight.
- G - Front left-hand high beam headlight.
- H - Right front sidelight.



38 - REAR LIGHTS

- A - Rear left-hand indicator light.
- B - Rear left-hand stop light.
- C - Left rear light.
- D - Rear fog light.
- E - Rear reversing light.
- F - Right rear light.
- G - Rear right-hand stop light.
- H - Rear right-hand indicator light.

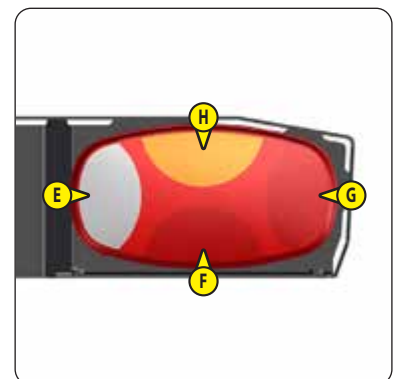
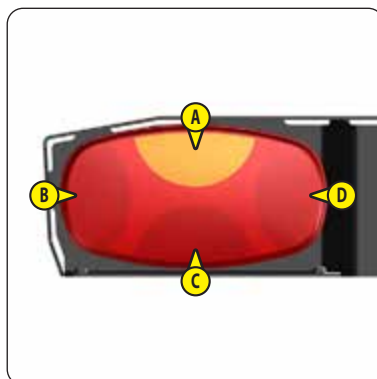

39 - ROTATING BEACON LIGHT

The magnetic rotating beacon light must be clearly visible on the roof of the cab and plugged into socket 1.



40 - BOOM SAFETY WEDGE

⚠ IMPORTANT ⚠

Only use the wedge supplied with the lift truck.

The lift truck is equipped with a boom safety wedge which must be installed on the rod of the lifting cylinder when working beneath the boom (⚠ 1 - OPERATING AND SAFETY INSTRUCTIONS).



41 - FUEL TANK

As far as possible, keep the fuel tank well filled in order to minimize condensation due to the atmospheric conditions.

⚠ IMPORTANT ⚠

Never smoke or approach with a flame during filling operations or when the tank is open.

Never refill while the engine is running.

- If necessary, add diesel (⚠ 3 - MAINTENANCE: LUBRICANTS AND FUEL).
- Remove the cap 1.
- Fill the fuel tank with clean diesel filtered through the filler port.
- Refit the cap.
- Visually check that there is no leakage in the tank and pipes.

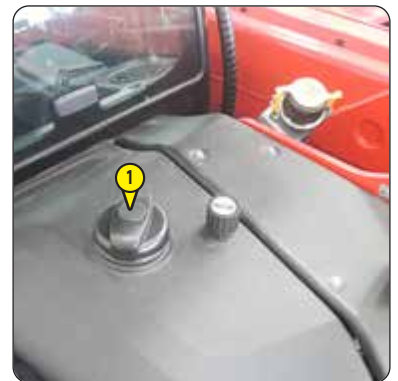

TOWING DEVICE

1 - TOWING PIN	2-61
2 - REAR ELECTRIC SOCKET (OPTION)	2-61

⚠ IMPORTANT ⚠

Do not tow a trailer or an attachment that is not in perfect working condition.

Using a trailer in poor condition may affect the lift truck's steering and braking, and hence the safety of the assembly.

If a third party helps in coupling or uncoupling the trailer, this person must remain visible to the driver at all times and must wait until the lift truck has stopped, the handbrake is on and the engine is switched off before performing the operation.

Located at the rear of the lift truck, this device is used to attach a trailer. Its capacity is limited for each lift truck by the authorized gross vehicle weight, tractive effort and maximum vertical force on the coupling point. This information is given on the manufacturer's plate fixed to each lift truck (← IDENTIFICATION OF THE LIFT TRUCK).

- To use a trailer, see current regulations in your country (maximum running speed, braking, maximum weight of trailer, etc.).
- Verify the trailer's condition before using it (tire condition and pressures, electrical connection, hydraulic hose, brake system, etc.).

N.B.: Our tractor type-approved lift trucks are not compatible for use with trailers fitted with the ISO7638 socket.

1 - TOWING PIN

⚠ IMPORTANT ⚠

Be careful not to get your fingers caught or crushed during this operation.

Do not forget to put the cotter pin back in place.

When uncoupling, make sure that the trailer is supported independently

COUPLING AND UNCOUPLING THE TRAILER

- To couple the trailer, position the lift truck as close as possible to the trailer ring.
- Apply the parking brake and switch off the engine.
- Remove the pin 1, lift the towing pin 2 and place or remove the trailer ring.



2 - REAR ELECTRIC SOCKET (OPTION)

- Connect the male plug to the female socket 1 on the lift truck and make sure the lights of the trailer or the light bar are working properly.



DESCRIPTION AND USE OF THE OPTIONS

1 - CAB REAR TRIM	2-63
2 - WATERPROOF DOCUMENT HOLDER	2-63
3 - STEERING WHEEL ADJUSTMENT LEVER	2-63
4 - ANTI-BREACH BAR	2-63
5 - WINDSHIELD GRILLE	2-63
6 - SUN VISOR.....	2-64
7 - INTERNAL REAR-VIEW MIRROR.....	2-64
8 - TELEPHONE HOLDER	2-64
9 - ANGULAR SECTOR ON BOOM	2-64
10 - MARKS ON BOOM	2-64
11 - LIFTING RING ON SINGLE CARRIAGE.....	2-64
12 - REFLECTIVE BANDS	2-65
13 - LICENSE PLATE LIGHT	2-65
14 - COMPACT LED ROTATING BEACON LIGHT	2-65
15 - GREEN ROTATING BEACON LIGHT	2-65
16 - BOOM ELECTRICAL PREDISPOSITION.....	2-65
17 - FUEL PREHEATER	2-66
18 - ENGINE BLOCK HEATER.....	2-66
19 - "STOP&START" ENGINE.....	2-66
20 - ENGINE SPEED REGULATOR.....	2-67
21 - SPEED LIMITER	2-67
22 - PIN PAD "EasyMANAGER"	2-68
23 - ATTACHMENT EASY HYDRAULIC CONNECTION.....	2-69
24 - ATTACHMENT CIRCUIT MANUAL OVERRIDE	2-69
25 - EXTERIOR DRAIN-BACK.....	2-70
26 - ATTACHMENT HYDRAULIC LOCKING.....	2-70
27 - BOOM HEAD ELECTROVALVE	2-71
28 - BOOM HEAD ELECTROVALVE + HYDRAULIC ATTACHMENT LOCKING	2-72
29 - SAFETY PACK	2-73

1 - CAB REAR TRIM



2 - WATERPROOF DOCUMENT HOLDER



3 - STEERING WHEEL ADJUSTMENT LEVER

This handle enables the angle and height of the steering wheel to be adjusted.

- Pull the handle 1 backwards.
- Adjust the steering wheel to the desired position.
- Push the knob back to lock the steering wheel in position.



4 - ANTI-BREACH BAR



5 - WINDSHIELD GRILLE

DESCRIPTION

The windshield grille provides additional protection for the operator from any external elements spattered on the windshield.



6 - SUN VISOR

7 - INTERNAL REAR-VIEW MIRROR

8 - TELEPHONE HOLDER

9 - ANGULAR SECTOR ON BOOM

The angular sector displays the boom angle, and thus improves the reading of the load charts.

10 - MARKS ON BOOM

The marking indicates the outreach of the boom and therefore improves reading of the load charts.

11 - LIFTING RING ON SINGLE CARRIAGE

CONDITIONS OF USE

⚠ IMPORTANT ⚠

Follow the instructions given in the instruction manual (⚠ 1 - OPERATING AND SAFETY INSTRUCTIONS: INSTRUCTIONS ON HANDLING LOADS), in addition to those given below.

- The lifting ring must be used WITHOUT FORKS AND ATTACHMENTS, but the angle of inclination of the carriage must be same as when the forks are used in the horizontal position.
- Check the maximum permitted angle, which is 45°.
- Do not change the angle of the carriage while using the lifting ring.
- The lifting hook, the chains and slings shall have a minimum capacity of 3000 kg with a safety coefficient of 4 in relation to breakage.

LOAD CHARTS AND FUNCTION SHEETS

⚠ IMPORTANT ⚠

The load charts are defined for use without forks and without attachments.

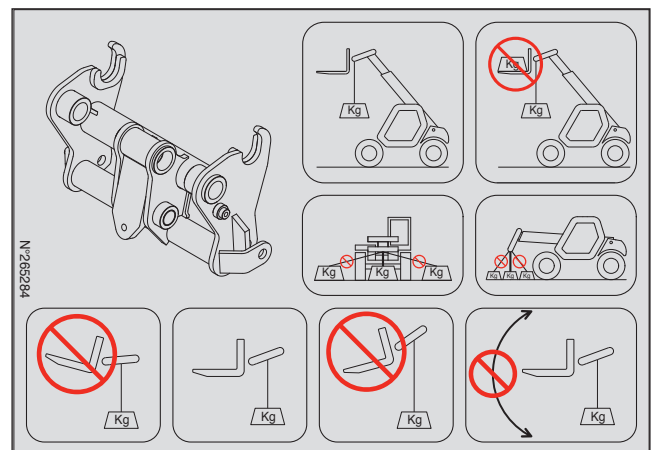
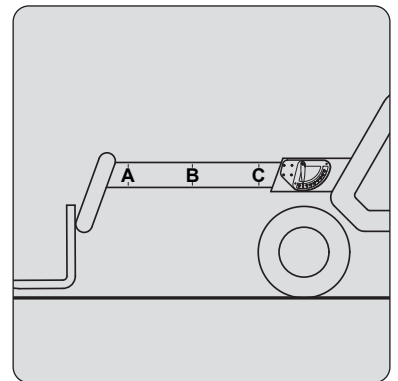

12 - REFLECTIVE BANDS

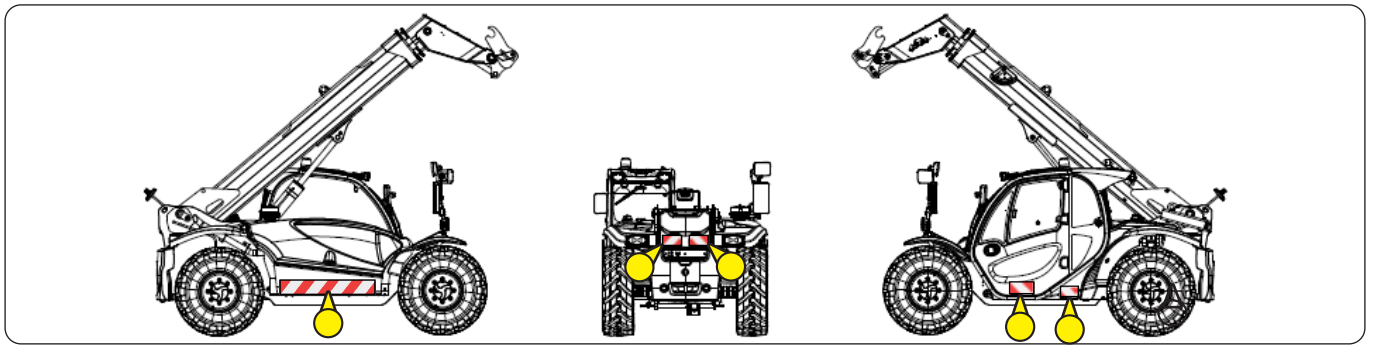

13 - LICENSE PLATE LIGHT



14 - COMPACT LED ROTATING BEACON LIGHT

The magnetic rotating beacon light must be clearly visible on the roof of the cab and plugged into socket 1.



15 - GREEN ROTATING BEACON LIGHT

The magnetic green rotating beacon light must be clearly visible on the roof of the cab and plugged in to socket 1.

- It indicates that the operator has fastened the seat belt.
- Do not use the green rotating beacon light on public roads.



16 - BOOM ELECTRICAL PREDISPOSITION

Enables an electrical function to be used at the head of the jib.

OPERATION

- Set switch 1 to position A to activate the predisposition. The indicator lamp comes on to show that it is activated.



17 - FUEL PREHEATER

The paraffin particles found naturally in diesel crystallize at low temperatures. The fuel preheater limits their accumulation in the filter.

18 - ENGINE BLOCK HEATER

Enables the engine to be kept warm during prolonged periods of stoppage and thus improves engine starting.

ENVIRONMENTAL CONDITIONS FOR USE:

- Maximum ambient temperature for using preheat: + 25 °C.

CONDITIONS FOR CONNECTION AND USE OF PREHEATING:

- The preheating system should not be used for an external ambient temperature higher than + 25 °C.
- It is essential that the power supply to the preheating system:
 - Is effected with a cable that conforms to the installation standards in force and contains a protective earth conductor.
 - Contains an appropriate sectioning system.
 - Include an appropriate short-circuit protection system (fuses or circuit breaker) and a ground-fault circuit breaker, sensitive to 30 mA.
- Only connect to and disconnect from the power supply while the unit is switched off and the engine is stopped.



⚠ IMPORTANT ⚠



Make sure that the electrical extension is still correctly stored in its place in the document holder net.

19 - "STOP&START" ENGINE

This function can take charge of engine shutdown to reduce consumption. It can be used if all of the following conditions are met within a timeframe defined by the operator.

- Engine on.
- Engine speed less than 1,000 rpm.
- No driver presence.
- No manual override in progress.
- No "stationary lift truck" exhaust regeneration".
- Parking brake applied.
- Engine coolant temperature higher than 50 °C.

TIME DELAY ADJUSTMENT

- Press the button  to display the "PREFERENCES" menu.
- Press the button  to select from the menus and sub-menus.

ENGINE > STOP&START

- Select a time delay between 1 and 30 minutes and press the  button to confirm.

OPERATION

- Press the  button to activate. The indicator light will come on, showing that it is in use.

⚠ IMPORTANT ⚠

The "STOP&START" function does not under any circumstances replace lift truck shutdown. You must shut down the lift truck at the end of the job or the end of the day (← 1 - OPERATING AND SAFETY INSTRUCTIONS: OPERATOR INSTRUCTIONS: OPERATING INSTRUCTIONS WITH AND WITHOUT LOAD: G - STOPPING THE LIFT TRUCK).

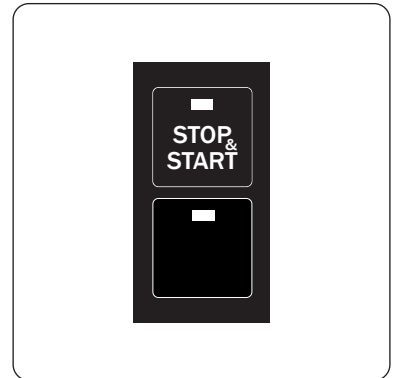

20 - ENGINE SPEED REGULATOR



⚠ IMPORTANT ⚠

The engine speed regulator cannot under any circumstances be used while driving on the road.





USING THE REGULATOR

- Control the engine speed with lever 1.

SPEED MEMORIZATION

- Control the engine speed with lever 1 or the accelerator pedal.
- Hold down the  button to memorize the engine speed.
- Press the  button again or operate lever 1 to return to idle speed.

ACTIVATING THE MEMORIZED ENGINE SPEED



- Press the  button to activate the memorized engine speed.
- Confirm by pressing the  button again or pressing the  button.
- Press the  button again or operate lever 1 to return to idle speed.









21 - SPEED LIMITER

⚠ IMPORTANT ⚠



BE CAREFUL when using the speed limiter while driving.

As soon as  appears on the information screen, selecting the speed with knob  will act directly on the lift truck and may cause it to decelerate sharply. Always reduce speed before use.

SPEED LIMITER USE AND MEMORIZATION

- Turn the navigation knob A to select driving mode .
- Hold down the  button,  will appear on the information screen.
- Press the knob  or  to select the speed.
- Press the  button to confirm and set.
- The memorized speed will be displayed on the information screen .

ACTIVATING THE MEMORIZED SPEED

- Press the  button to activate. The indicator light will come on, showing that it is in use.
- The speed limiter recall  on the information screen also indicates that it is in use.
- Press the button again to deactivate.



22 - PIN PAD "EasyMANAGER"

A code must be created for the operator via the "EasyMANAGER" portal. For more information, contact your dealer.

OPERATION

BY ID CODE

- Switch on lift truck ignition, LED 1 comes on.
- Enter your ID code and confirm by pressing the "V" key.
- LED 2 comes on to confirm the operator's identification.
- Immediately start the lift truck, otherwise the identification process is canceled and LED 2 turns red.

N.B.: In case of an input error, LED 2 lights up red, press the "X" key, and wait 10 seconds before entering the correct identification code.

BY ID CARD

- Switch on lift truck ignition, LED 1 comes on.
- Present your ID card; an audible beep confirms that the card has been read.
- LED 2 comes on to confirm the operator's identification.
- Immediately start the lift truck, otherwise the identification process is canceled and LED 2 turns red.

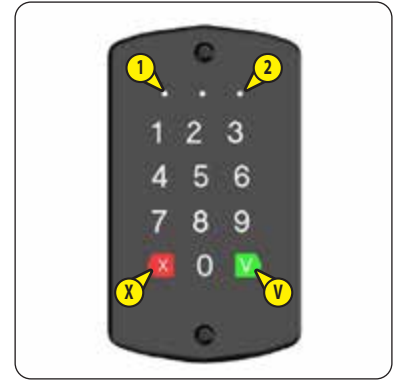



23 - ATTACHMENT EASY HYDRAULIC CONNECTION

For easy connection and disconnection of hydraulic attachments.

PUSH BUTTON OPERATION

- Switch on lift truck ignition.
- Press for two seconds on pushbutton 1 to release the attachment circuit hydraulic pressure.
- Connect or disconnect the quick couplers of the hydraulic attachment (↩ 4 - ADAPTABLE ATTACHMENTS AS AN OPTION ON THE RANGE: PICKING UP THE ATTACHMENTS).

PREFERENCES MENU BUTTON OPERATION

- Switch on lift truck ignition.
 - Press the button  to display the "PREFERENCES" menu.
 - Press the button  to select from the menus and sub-menus.
- | | | |
|-----------|---|---------------------|
| HYDRAULIC | > | EASY CONNECT SYSTEM |
|-----------|---|---------------------|
- Press knob  to confirm.
 - Connect or disconnect the quick couplers of the hydraulic attachment (↩ 4 - ADAPTABLE ATTACHMENTS AS AN OPTION ON THE RANGE: PICKING UP THE ATTACHMENTS).









24 - ATTACHMENT CIRCUIT MANUAL OVERRIDE





⚠ IMPORTANT ⚠

This OPTION should only be used with an attachment that requires continuous hydraulic movement such as: a sweeper, feed wagon, mixer, sprayer, etc. It is strictly prohibited for handling operations and for all other attachments (winch, crane, crane jib with winch, hook, etc.).

USING AND STORING MANUAL OVERRIDE

- Press the  button to select the operating mode .
- Hold down the  button;  will appear on the information screen.
- Press buttons   to set the flow rate.
- Press the  button to confirm and set.

ACTIVATING THE STORED MANUAL OVERRIDE

- Press the  button to activate manual override.
- Confirm by pressing the  button again or pressing the  button.
- Press the  button again to deactivate.

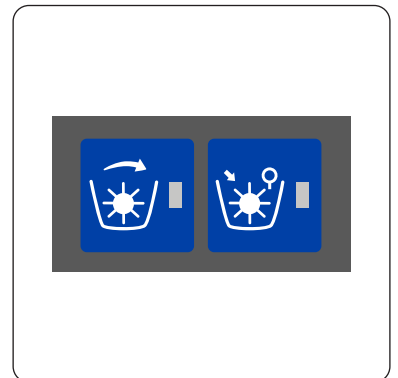

25 - EXTERIOR DRAIN-BACK

Enables connection of an attachment for which drain-back to the hydraulic tank is required.





26 - ATTACHMENT HYDRAULIC LOCKING

Enables the attachment to be locked onto the carriage and a hydraulic attachment to be used by the same circuit.

⚠ IMPORTANT ⚠

After locking the attachment, turn off the switch  (indicator lamp off) to prevent accidental unlocking of the attachment.

ATTACHMENT LOCKING CONTROL

- Turn on the  switch (indicator lamp on).
- Push switch 2 forward to lock the attachment and backward to release it.
- Turn off the  switch (indicator lamp off).

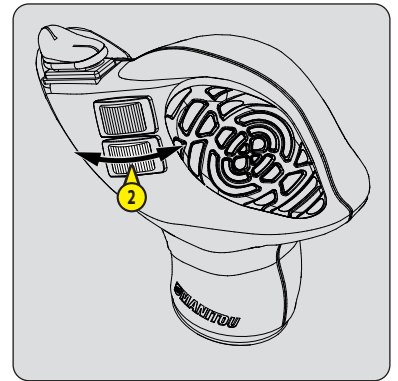
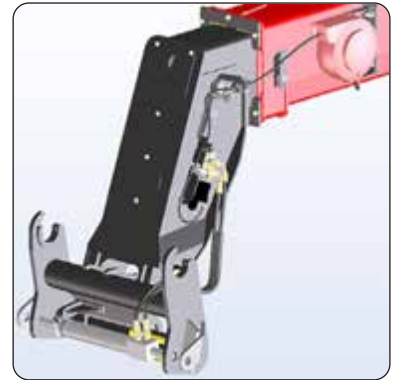

27 - BOOM HEAD ELECTROVALVE

Enables use of two hydraulic functions on the attachment circuit.

N.B.: For ease of connection of the quick-release couplers, decompress the hydraulic circuit by pressing button 1 on the electrovalve.

ATTACHMENT LINE CONTROL "C1-C4"

- Push switch 2 forward or backward to control the attachment line "C1-C4".

ATTACHMENT LINE CONTROL "C2-C3"

- Hold down button 3 and push switch 2 forward or backward to control the attachment line "C2-C3".

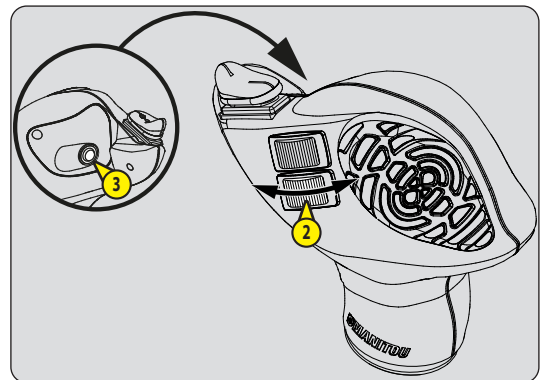
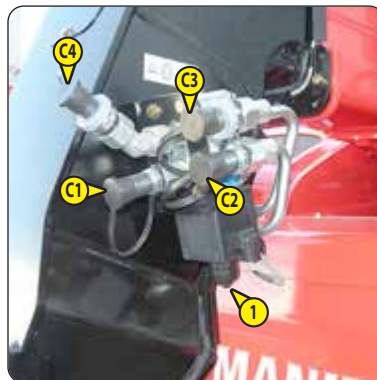
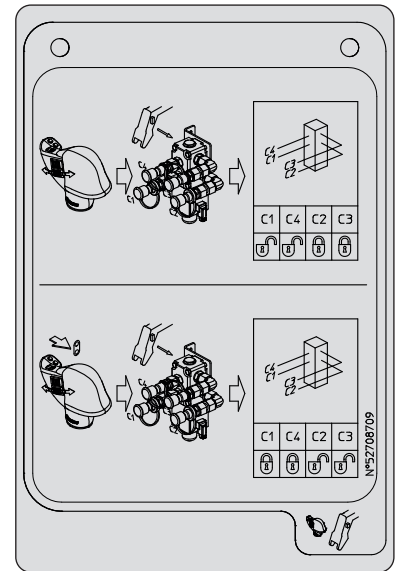

28 - BOOM HEAD ELECTROVALVE + HYDRAULIC ATTACHMENT LOCKING

The addition of these two options on the attachment line allows two hydraulic functions to be used and locks the attachment onto the carriage.

N.B.: For ease of connection of the quick-release couplers, decompress the hydraulic circuit by pressing button 1 on the electrovalve.



⚠ IMPORTANT ⚠

After locking the attachment, turn off the switch  (indicator lamp off) to prevent accidental unlocking of the attachment.

ATTACHMENT LINE CONTROL "C1-C4"

- Turn off the  switch (indicator lamp off).
- Push switch 2 forward or backward to control the attachment line "C1-C4".

ATTACHMENT LOCKING CONTROL "C2-C3"

- Turn on the  switch (indicator lamp on).
- Hold down button 3 and push button 2 forward to lock the attachment and backward to release it.
- Release knobs 2 and 3.
- Turn off the  switch (indicator lamp off).

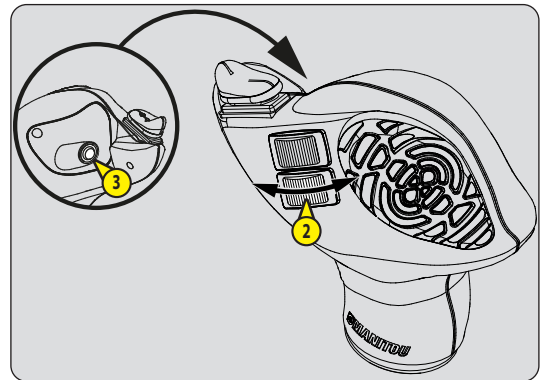
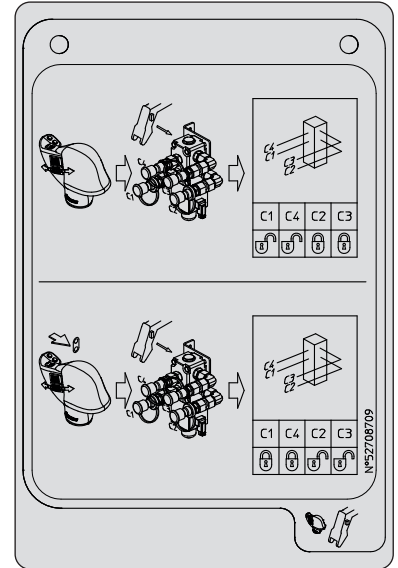

29 - SAFETY PACK

REAR PARKING AID

Progressive visual and audible alarm.

- 2M50 to 1M00 => 1 light bar + 1 beep intermittently.
- 1M00 to 0M60 => 4 light bars + 4 beeps intermittently.
- 0M60 to 0M00 => 8 light bars + continuous beep



HYDRAULIC BOOM CONTROLS

A1 - LIFTING

N.B.: Lifting of the boom on tires is limited to 40°.

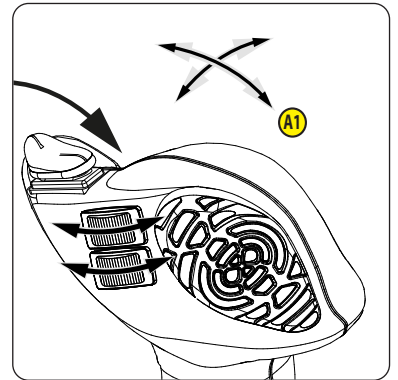

SEAT BELT SENSOR

◀ SAFETY LOGIC DESCRIPTION



FLASHING LIGHT

◀ SAFETY LOGIC DESCRIPTION













DOOR WINDOW ANTI-BREACH BAR



RED ROTATING BEACON LIGHT



SAFETY LOGIC DESCRIPTION

	Dashboard warning message.
	Machine travel (km/h).
	Cab door.
	Boom angle.
	Seat belt
	Presence of driver on seat.
	Machine lateral angle.
	Rear axle offloading + deactivation of "aggravating" hydraulic movement cut-off
	Cab flashing light + red rotating beacon light.
	Permanently

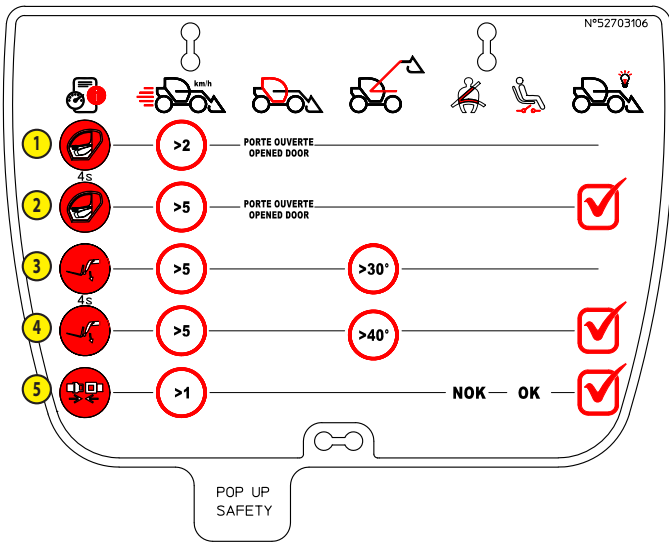

- 1 => Risky driving - Close the door
- 2 => Risky driving - Close the door
- 3 => Risky driving - Lower the boom
- 4 => Risky driving - Lower the boom
- 5 => Risky driving - Put on the seat belt

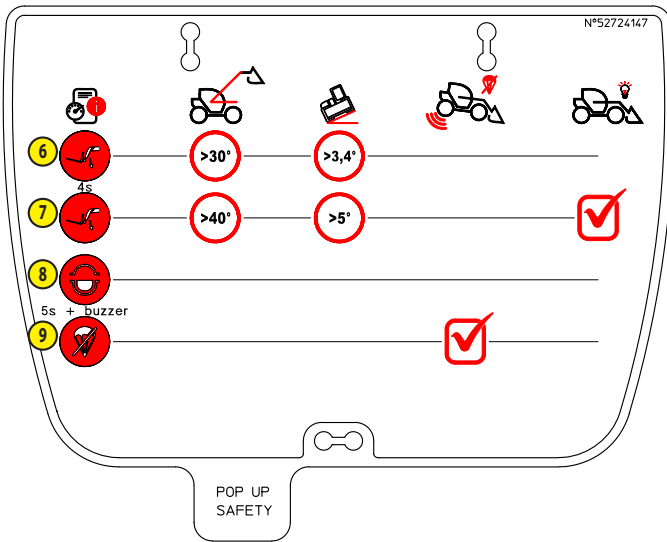

- 6 => Risky driving - Close the door
- 7 => Risky driving - Lower the boom
- 8 => Water in diesel
- 9 => Stability system deactivation

3 - MAINTENANCE

3 - MAINTENANCE

ORIGINAL MANITOU SPARE PARTS AND EQUIPMENT	3-3
FORKLIFT TRUCK MAINTENANCE	3-4
DAILY AND WEEKLY MAINTENANCE	3-4
MANDATORY FIRST 500 HOURS OR 6 MONTHS OF SERVICE	3-5
PERIODIC MAINTENANCE	3-6
OCCASIONAL MAINTENANCE AND OPERATION	3-8
FILTER CARTRIDGES AND BELTS	3-9
LUBRICANTS AND FUEL	3-10
➞ 10H - DAILY SERVICE OR EVERY 10 HOURS OF SERVICE	3-12
➞ 50H - WEEKLY MAINTENANCE OR EVERY 50 HOURS OF SERVICE	3-14
➞ ① 500H - PERIODIC MAINTENANCE - EVERY 500 HOURS OF SERVICE OR 1 YEAR	3-20
➞ ② 1000H - PERIODIC MAINTENANCE - EVERY 1000 HOURS OF SERVICE OR EVERY 2 YEARS	3-24
➞ ③ 2000H - PERIODIC MAINTENANCE - EVERY 2000 HOURS OF SERVICE OR EVERY 4 YEARS	3-30
➞ ④ 3000H - PERIODIC MAINTENANCE - EVERY 3,000 HOURS OF SERVICE OR EVERY 6 YEARS	3-33
➞ OCCASIONAL MAINTENANCE	3-34
➞ OCCASIONAL OPERATION	3-38

ORIGINAL MANITOU SPARE PARTS AND EQUIPMENT

OUR LIFT TRUCKS MUST BE SERVICED USING ORIGINAL MANITOU PARTS.

BY ALLOWING THE USE OF NON ORIGINAL MANITOU PARTS, YOU RISK:

⚠ IMPORTANT ⚠

THE USE OF COUNTERFEIT PARTS OR COMPONENTS NOT APPROVED BY THE MANUFACTURER MEANS YOU LOSE THE BENEFIT OF THE CONTRACTUAL GUARANTEE.

- Legally, incurring liability in the event of an accident.
- Technically - to cause operating malfunctions or shorten the life of the lift truck.

BY USING ORIGINAL MANITOU PARTS FOR MAINTENANCE OPERATIONS, YOU BENEFIT FROM OUR KNOW-HOW

Through its network, MANITOU provides the user with,

- Know-how and competence.
- The guarantee of high-quality work.
- Original replacement parts.
- Help with preventive maintenance.
- Efficient help with diagnosis.
- Improvements as a result of feedback.
- Operator training.
- Only the MANITOU network has detailed knowledge of the design of the lift truck and therefore the best technical ability to provide maintenance.

⚠ IMPORTANT ⚠

ORIGINAL REPLACEMENT PARTS ARE DISTRIBUTED EXCLUSIVELY BY MANITOU AND ITS DEALER NETWORK.

The dealer network list is available on the MANITOU web site: www.manitou.com

FORKLIFT TRUCK MAINTENANCE

DAILY AND WEEKLY MAINTENANCE



THE OPERATOR IS AUTHORIZED TO CARRY OUT THIS MAINTENANCE.

These maintenance operations enable the operator to maintain the lift truck in a clean and safe condition.

MANDATORY FIRST 500 HOURS OR 6 MONTHS OF SERVICE



THIS SERVICE MUST BE CARRIED OUT AFTER THE FIRST 500 HOURS OF SERVICE OR WITHIN THE 6 MONTHS FOLLOWING PUTTING THE MACHINE INTO SERVICE (WHICHEVER OCCURS FIRST).

PERIODIC MAINTENANCE



THE PERIODIC MAINTENANCE MUST BE CARRIED OUT BY A PROFESSIONAL APPROVED BY THE MANITOU NETWORK

MAINTENANCE SCHEDULE

This schedule enables the operator to keep up with the periodic maintenance of the lift truck by notifying the total number of hours of operation and the date of the service performed by the professional approved by the MANITOU network.

OCCASIONAL MAINTENANCE AND OPERATION

These maintenance tasks and operations are to be performed as required for the safety and upkeep of the lift truck.

DAILY AND WEEKLY MAINTENANCE

↻ 10H - DAILY SERVICE OR EVERY 10 HOURS OF SERVICE

- CHECK	Lift truck environment	3-12
- CHECK	Engine oil level.....	3-12
- CHECK	Coolant level.....	3-12
- CHECK	Longitudinal stability limiter and warning device.....	3-13

↻ 50H - WEEKLY MAINTENANCE OR EVERY 50 HOURS OF SERVICE

- CHECK	Alternator/crankshaft belt tension.....	3-14
- CHECK	Compressor belt tension (Air conditioning option).....	3-14
- CHECK	Transfer box oil level	3-14
- CHECK	Tire pressure.....	3-14
- CHECK	Wheel nut tightening	3-14
- CHECK	Front axle differential seal	3-15
- CHECK	Rear axle differential seal	3-15
- CHECK	Front wheel reducer seals	3-15
- CHECK	Rear wheel reducer seals	3-15
- CHECK	Brake fluid level.....	3-15
- CHECK	Boom pad slide pathways	3-15
- CHECK	Hydraulic fluid level.....	3-16
- CHECK	Windshield washer fluid level.....	3-16
- CLEAN	Fuel pre-filter	3-16
- CLEAN	Radiator cores	3-17
- CLEAN	Dry air filter cartridge	3-17
- CLEAN	Condenser harness (Air conditioning OPTION)	3-17
- LUBRICATE	General lubrication	3-18
- REPLACE	Engine oil *	3-19
- REPLACE	Engine oil filter *	3-19

*** Only for the first 50 hours of service and then every 500 hours of service or 1 year.**

MANDATORY FIRST 500 HOURS OR 6 MONTHS OF SERVICE

FIRST 500 HOURS BEFORE THE FIRST 6 MONTHS

- If the lift truck has reached the first 500 hours of service before the first 6 months have expired, perform both the mandatory service and periodic 500 H service (◀ ➡ ① 500H - PERIODIC SERVICE - EVERY 500 HOURS OF SERVICE OR 1 YEAR).

FIRST 6 MONTHS BEFORE THE FIRST 500 HOURS

- If the lift truck has not completed 500 hours of service in the first 6 months, just carry out the mandatory service.

MANDATORY SERVICE

- CHECK	Alternator/crankshaft belt tension	3-14
- CHECK	Compressor belt tension (Air conditioning option)	3-14
- CHECK	Transfer box oil level	3-14
- CHECK	Tire pressure	3-14
- CHECK	Wheel nut tightening	3-14
- CHECK	Front axle differential seal	3-15
- CHECK	Rear axle differential seal	3-15
- CHECK	Front wheel reducer seals	3-15
- CHECK	Rear wheel reducer seals	3-15
- CHECK	Brake fluid level	3-15
- CHECK	Boom pad slide pathways	3-15
- CHECK	Hydraulic fluid level	3-16
- CHECK	Windshield washer fluid level	3-16
- CLEAN	Fuel pre-filter	3-16
- CLEAN	Radiator cores	3-17
- CLEAN	Dry air filter cartridge	3-17
- CLEAN	Condenser harness (Air conditioning OPTION)	3-17
- LUBRICATE	General lubrication	3-18
- CHECK	Hoses and differential pressure hoses for the exhaust particle filter "DPF" **	3-23
- CHECK	Exhaust gas recirculation piping "EGR" **	3-23
- CHECK	Intake hose **	3-23
- CHECK	**Exhaust manifold	3-23
- CHECK	Fork wear *	3-23
- CHECK	Seat belt	3-24
- CHECK	Silentblocks **	3-28
- CHECK	Valve lash **	3-28
- CHECK	Injectors **	3-28
- CHECK	Exhaust gas recirculation cooler "EGR" **	3-28
- CHECK	Casing gas recycling valve **	3-28
- CHECK	Rear axle locking cylinder *	3-28
- CHECK	Brake system pressure *	3-28
- CHECK	Boom pad wear *	3-28
- CHECK	Condition of wiring harnesses and cables *	3-28
- CHECK	Lights and signals *	3-28
- CHECK	Warning indicators *	3-28
- CHECK	Condition of the rear view mirrors *	3-28
- CHECK	Cab structure *	3-28
- CHECK	Chassis structure *	3-28
- CHECK	Attachment mounting system *	3-28
- CHECK	Condition of attachments *	3-28
- BLEED	Rear axle locking cylinder *	3-29

**** Engine service, consult your dealer.**

*** Consult your dealer.**

PERIODIC MAINTENANCE

MAINTENANCE SCHEDULE

SCHEDULE →	↻ OR ↻		500 H or 1 YEAR	1000 H or 2 YEARS	1500 H or 3 YEARS	2000 H or 4 YEARS
	FIRST 6 MONTHS	FIRST 500 HOURS				
PERIODIC MAINTENANCE →	MANDATORY SERVICE	MANDATORY SERVICE + ①	①	①+②	①	①+②+③
MACHINE COUNTER →						
DATE OF SERVICING →						

SCHEDULE →	2500 H or 5 YEARS	3000 H or 6 YEARS	3500 H or 7 YEARS	4000 H or 8 YEARS	4500 H or 9 YEARS	5000 H or 10 YEARS	5500 H or 11 YEARS
PERIODIC MAINTENANCE →	①	①+②+④	①	①+②+③	①	①+②	①
MACHINE COUNTER →							
DATE OF SERVICING →							

SCHEDULE →	6000 H or 12 YEARS	6500 H or 13 YEARS	7000 H or 14 YEARS	7500 H or 15 YEARS	8000 H or 16 YEARS	8500 H or 17 YEARS	9000 H or 18 YEARS
PERIODIC MAINTENANCE →	①+②+③+④	①	①+②	①	①+②+③	①	①+②+④
MACHINE COUNTER →							
DATE OF SERVICING →							

→ ① 500H - PERIODIC MAINTENANCE - EVERY 500 HOURS OF SERVICE OR 1 YEAR

- CHECK	Hydraulic oil	3-20
- REPLACE	Engine oil	3-20
- REPLACE	Engine oil filter	3-20
- REPLACE	Fuel filter	3-21
- REPLACE	Fuel pre-filter	3-21
- REPLACE	Transfer box oil	3-21
- REPLACE	Front axle differential oil	3-22
- REPLACE	Hydraulic return oil filter cartridge	3-22
- REPLACE	Hydraulic oil tank filter cap	3-23
- REPLACE	Cab fan filter	3-23
- CHECK	Hoses and differential pressure hoses for the exhaust particle filter "DPF" **	3-23
- CHECK	Exhaust gas recirculation piping "EGR" **	3-23
- CHECK	Intake hose **	3-23
- CHECK	**Exhaust manifold	3-23
- CHECK	Fork wear *	3-23

**** Engine service, consult your dealer.**

*** Consult your dealer.**

➔ ② 1000H - PERIODIC MAINTENANCE - EVERY 1000 HOURS OF SERVICE OR EVERY 2 YEARS

ALSO CARRY OUT THE PERIODIC MAINTENANCE FOR 500 HOURS OF SERVICE.

- CHECK	Seat belt	3-24
- CLEAN	Fuel tank	3-24
- REPLACE	Fuel tank breather	3-24
- REPLACE	Alternator belt	3-25
- REPLACE	Engine crankcase ventilation filter	3-26
- REPLACE	Dry air filter cartridge	3-26
- REPLACE	Coolant	3-27
- REPLACE	Rear axle differential oil	3-27
- REPLACE	Front wheel reducer oil	3-28
- REPLACE	Rear wheel reducer oil	3-28
- CHECK	Silentblocks **	3-28
- CHECK	Valve lash **	3-28
- CHECK	Injectors **	3-28
- CHECK	Exhaust gas recirculation cooler "EGR" **	3-28
- CHECK	Casing gas recycling valve **	3-28
- CHECK	Rear axle locking cylinder *	3-28
- CHECK	Brake system pressure *	3-28
- CHECK	Boom pad wear *	3-28
- CHECK	Condition of wiring harnesses and cables *	3-28
- CHECK	Lights and signals *	3-28
- CHECK	Warning indicators *	3-28
- CHECK	Condition of the rear view mirrors *	3-28
- CHECK	Cab structure *	3-28
- CHECK	Chassis structure *	3-28
- CHECK	Attachment mounting system *	3-28
- CHECK	Condition of attachments *	3-28
- REPLACE	Brake fluid *	3-29
- BLEED	Rear axle locking cylinder *	3-29
- BLEED	Braking system *	3-29
- ADJUST	Brake *	3-29

**** Engine service, consult your dealer.**

*** Consult your dealer.**

➔ ③ 2000H - PERIODIC MAINTENANCE - EVERY 2000 HOURS OF SERVICE OR EVERY 4 YEARS

ALSO PERFORM THE 500 HOUR AND 1000 HOUR PERIODIC MAINTENANCE.

- CHECK	Wheel nut tightening torque	3-30
- REPLACE	Dry air filter safety cartridge	3-30
- REPLACE	Hydraulic oil	3-31
- CLEAN	Hydraulic fluid tank suction strainers	3-31
- REPLACE	Brake accumulator unit filter	3-31
- CHECK	Radiator *	3-32
- CHECK	Transmission pressures *	3-32
- CHECK	Steering *	3-32
- CHECK	Steering swivel joints *	3-32
- CHECK	Brake pad and brake disk wear *	3-32
- CHECK	Condition of boom assembly *	3-32
- CHECK	Bearings and bushings *	3-32
- CHECK	Condition of hoses and flexible pipes *	3-32
- CHECK	Condition of cylinders (leakage, rods) *	3-32
- CHECK	Hydraulic circuit pressures *	3-32
- CLEAN	Air conditioning (OPTION) *	3-32
- REPLACE	Compressor belt (Air Conditioning OPTION) *	3-32

*** Consult your dealer.**

➔ ④ 3000H - PERIODIC MAINTENANCE - EVERY 3,000 HOURS OF SERVICE OR EVERY 6 YEARS

ALSO PERFORM THE 500 HOUR AND 1000 HOUR PERIODIC MAINTENANCE.

- CHECK	Turbocharger **	3-33
- CHECK	Exhaust gas recirculation system "EGR" **	3-33
- CLEAN	Exhaust particle filter "DPF" **	3-33

**** Engine service, consult your dealer.**

OCCASIONAL MAINTENANCE AND OPERATION

➔ OCCASIONAL MAINTENANCE

- CLEAN	Lift truck	3-34
- CLEAN	"Stationary lift truck" exhaust regeneration	3-35
- REPLACE	Wheels	3-36
- ADJUST	Front headlights	3-36
- RESET	Longitudinal stability limiter and warning device	3-37

➔ OCCASIONAL OPERATION

- TOW OR WINCH	Lift truck	3-38
- SLING	Lift truck	3-39
- TRANSPORT	Lift truck	3-40

FILTER CARTRIDGES AND BELTS

➔ ① 500H - PERIODIC MAINTENANCE - EVERY 500 HOURS OF SERVICE OR 1 YEAR

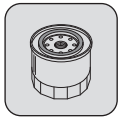

ENGINE OIL FILTER

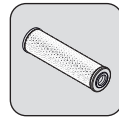

HYDRAULIC RETURN OIL FILTER CARTRIDGE



FUEL PRE-FILTER

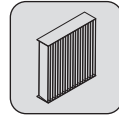

INTERIOR CAB VENTILATION FILTER

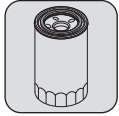

FUEL FILTER



BREATHER CAP FOR HYDRAULIC OIL TANK

➔ ② 1000H - PERIODIC MAINTENANCE - EVERY 1000 HOURS OF SERVICE OR EVERY 2 YEARS

ALSO ADD THE FILTER CARTRIDGES FROM THE PERIODIC MAINTENANCE FOR 500 HOURS OF SERVICE.



FUEL TANK BREATHER

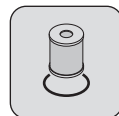

ENGINE CRANKCASE VENTILATION FILTER

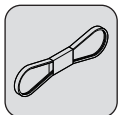

ALTERNATOR BELT

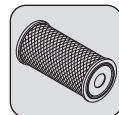

DRY AIR FILTER CARTRIDGE

➔ ③ 2000H - PERIODIC MAINTENANCE - EVERY 2000 HOURS OF SERVICE OR EVERY 4 YEARS

ALSO ADD FILTER ELEMENTS FOR PERIODIC MAINTENANCE AT 500 HOURS AND 1,000 HOURS OF SERVICE.

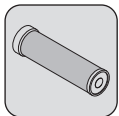

SAFETY DRY AIR FILTER CARTRIDGE

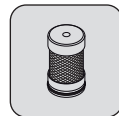

BRAKE ACCUMULATOR UNIT FILTER

➔ OCCASIONAL MAINTENANCE

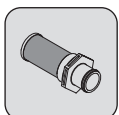

SUCTION STRAINER FOR HYDRAULIC OIL TANK

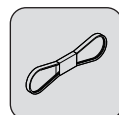

COMPRESSOR BELT
(AIR CONDITIONING OPTION)

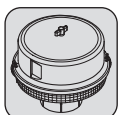

SELF-CLEANING PRE-FILTER (OPTION)

LUBRICANTS AND FUEL

⚠ IMPORTANT ⚠

- USE THE RECOMMENDED LUBRICANTS AND FUEL:**
- For topping up, oils may not be miscible.
 - For oil changes, MANITOU oils are perfectly appropriate.

DIAGNOSTIC ANALYSIS OF OILS

If a service or maintenance contract has been set up with the dealer, a diagnostic analysis of engine, transmission and axle oils may be requested depending on the rate of use.

(*) REQUIRED FUEL SPECIFICATION

Use a high-quality fuel to obtain optimal performance of the engine.

- EN590 diesel fuel (sulfur content < 10 ppm)
- Type of diesel fuel ASTM D975 (sulfur content < 15 ppm)

RECOMMENDATION

ENGINE		
DESCRIPTION	CAPACITY	RECOMMENDATION
		-40°C -30 -20 -10 0 +10 +20 +30 +40 +50°C
ENGINE	10,8 ℓ	
COOLING CIRCUIT	7 ℓ	COOLANT -35 °C
FUEL TANK	90 ℓ	HP NON-ROAD DIESEL (GNR) (*)
BOOM		
DESCRIPTION		RECOMMENDATION
		-40°C -30 -20 -10 0 +10 +20 +30 +40 +50°C
BOOM PAD SLIDE PATHWAYS		MANITOU BLACK MULTI-PURPOSE LUBRICANT
		-40°C -30 -20 -10 0 +10 +20 +30 +40 +50°C
GREASING OF THE BOOM		MANITOU BLUE MULTI-PURPOSE LUBRICANT
HYDRAULIC		
DESCRIPTION	CAPACITY	RECOMMENDATION
		-40°C -30 -20 -10 0 +10 +20 +30 +40 +50°C
HYDRAULIC OIL TANK	74 ℓ	
BRAKES		
DESCRIPTION	CAPACITY	RECOMMENDATION
BRAKE SYSTEM	1 ℓ	MANITOU MINERAL BRAKE FLUID
CAB		
DESCRIPTION	CAPACITY	RECOMMENDATION
WINDSHIELD WASHER TANK	2 ℓ	WINDSHIELD WASHER FLUID

FRONT AXLE											
DESCRIPTION	CAPACITY	RECOMMENDATION									
FRONT AXLE DIFFERENTIAL	2,3 ℓ	SPECIAL MANITOU OIL FOR IMMersed BRAKES									
		-40°C	-30	-20	-10	0	+10	+20	+30	+40	+50°C
TRANSFER GEAR BOX FRONT WHEEL REDUCING GEAR	0,75 ℓ 2 x 0,75 ℓ	MANITOU SAE80W90 MECHANICAL TRANSMISSION OIL									
		-40°C	-30	-20	-10	0	+10	+20	+30	+40	+50°C
FRONT WHEEL REDUCING GEAR PIVOTS		MANITOU BLACK MULTI-PURPOSE LUBRICANT									

REAR AXLE											
DESCRIPTION	CAPACITY	RECOMMENDATION									
REAR AXLE DIFFERENTIAL	4,2 ℓ	SPECIAL MANITOU OIL FOR IMMersed BRAKES									
		-40°C	-30	-20	-10	0	+10	+20	+30	+40	+50°C
REAR WHEEL REDUCING GEAR	2 x 0,75 ℓ	MANITOU SAE80W90 MECHANICAL TRANSMISSION OIL									
		-40°C	-30	-20	-10	0	+10	+20	+30	+40	+50°C
REAR AXLE OSCILLATION		MANITOU BLUE MULTI-PURPOSE LUBRICANT									
		-40 °C	-30	-20	-10	0	+10	+20	+30	+40	+50 °C
REAR WHEEL REDUCING GEAR PIVOTS		MANITOU BLACK MULTI-PURPOSE LUBRICANT									

CHECK

Lift truck environment

Carry out a general inspection around the lift truck:

- Fluid leaks or stains on the ground.
- Additional objects on the lift truck and in the cab.
- Mounting and locking of the attachment.
- Mounting and adjustment of rear-view mirrors.
- Condition of the tires, to detect cuts, blisters, wear, etc.

⚠ IMPORTANT ⚠

Follow the operator instructions (↩ 1 - OPERATING AND SAFETY INSTRUCTIONS: OPERATOR INSTRUCTIONS).

CLEANLINESS OF THE FORKLIFT

- Cleanliness of lights and rear-view mirror.
- Excess dirt or build-up of material (e.g. straw, flour, sawdust, organic waste, etc.).
- On a daily basis, according to the conditions of use and the environment, the operator should ensure that the forklift truck is kept in a clean condition.
- Particular attention should be paid to accumulations of flammable materials (e.g. straw, flour, sawdust, organic waste, etc.) and fuel or lubricant leaks, as these significantly increase the risk of fire outbreaks.
- A regular inspection of the whole lift truck, especially the engine housing and the central part of the chassis, is necessary to see how frequently it needs to be cleaned to prevent these potential accumulations of material or leakages.

CHECK

Engine oil level

Place the lift truck on level ground with the engine stopped, and let the oil settle in the sump.

- Open the engine hood.
- Pull out the dipstick 1.
- Clean the dipstick and check the correct level between the two notches.
- If necessary, add oil (↩ LUBRICANTS AND FUEL) through the filler hole 2.
- Visually check that there is no leakage or seepage.



CHECK

Coolant level

Place the lift truck on level ground with the engine stopped, and allow the engine to cool.

⚠ IMPORTANT ⚠



To avoid any risk of spraying or scalding, wait until the engine has cooled down before removing the cooling circuit filler plug.

In the event of an emergency, it is possible to use water as the coolant, but then proceed to drain the coolant circuit as quickly as possible.



- Open the engine hood.
- The liquid must be at mid-height in the expansion tank 1.
- If necessary, add coolant (↩ LUBRICANTS AND FUEL) through the filler hole 2.
- Visually check that there is no leakage or seepage.



Place the lift truck on flat, level ground with the wheels straight.

- Press the button  to display the "PREFERENCES" menu.
- Press the button  to select from the menus and sub-menus.



- Press knob  to confirm.
- Follow the steps described on the information screen (OK = press button )

⚠ IMPORTANT ⚠

If an error code is displayed, recalibrating the longitudinal stability limiter and warning device may resolve the problem (⚠ OCCASIONAL MAINTENANCE).

➔ 50H - WEEKLY MAINTENANCE OR EVERY 50 HOURS OF SERVICE

CHECK

Alternator/crankshaft belt tension

⚠ IMPORTANT ⚠

If the belt is changed, check the tension again after the first 20 hours of service.

- Open the engine hood.
- Check the belt for signs of wear and cracks, and change if necessary (☞ FILTER CARTRIDGES AND BELTS).
- Check the belt tension between the fan pulley and the alternator pulley (98 N). The clearance should be about 7 to 9 mm.
- Adjust if necessary.
- Loosen screws 1 by two to three thread turns.
- Swivel the alternator assembly so as to obtain the required belt tension.
- Retighten screws 1 (tightening torque 22 N.m).

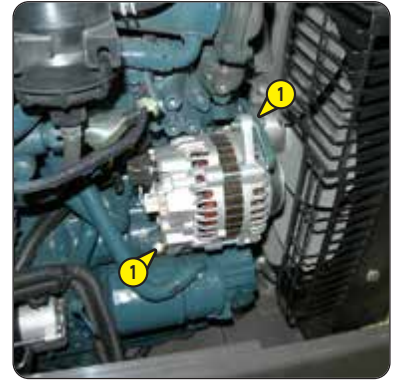

CHECK

Compressor belt tension (Air conditioning option)

⚠ IMPORTANT ⚠

If the belt is changed, check the tension again after the first 20 hours of service.

- Open the engine hood.
- Check the belt for signs of wear and cracks, and change if necessary (☞ FILTER CARTRIDGES AND BELTS).
- Check the belt tension between the pulleys of the crankshaft and the compressor.
- Under a normal pressure exerted with the thumb (45 N), the clearance should be approximately 10 mm.
- Adjust if necessary.
- Loosen the screws 1 and nuts 2 by two to three thread turns.
- Swivel the compressor assembly so as to obtain the belt tension required.
- Re-tighten screws 1 and nuts 2 (tightening torque 22 N.m).

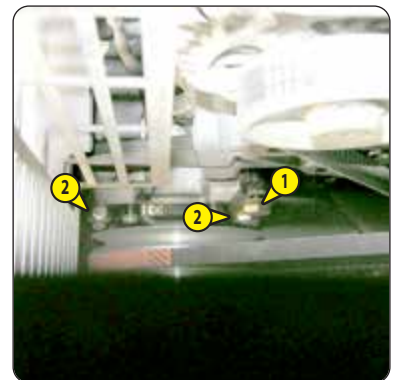

CHECK

Transfer box oil level

Place the lift truck on level ground with the engine stopped.

- Visually check for any traces of seepage or leakage from the various filler, level and drain plugs.
- If there is any leakage or seepage, check the level.
- Remove the level plug 1, the oil should be flush with the edge of the hole.
- If necessary, add oil (☞ LUBRICANTS AND FUEL) through the same hole.
- Refit and tighten the level plug 1 (tightening torque 35 - 50 N.m).



CHECK

Tire pressure

CHECK

Wheel nut tightening

⚠ IMPORTANT ⚠

Check that the air hose is correctly connected to the tire valve before inflating and keep all persons at a distance during inflation. Inflate to the recommended tire pressures.

- Check the condition of the tires, to detect cuts, blisters, wear, etc.
- Check the wheel nut torque. Non-compliance with this instruction can lead to deterioration and breakage of the wheel lugs and distortion of the wheels.
- Check and restore tire pressure, if necessary (☞ 2 - DESCRIPTION: TIRES).

N.B.: An OPTIONAL wheel tool kit is available.

CHECK

Front axle differential seal

CHECK

Rear axle differential seal

Place the lift truck on level ground with the engine stopped.

- Visually check for any traces of seepage or leakage from the various filler, level and drain plugs.
- If there is any leakage or seepage, check the level.
- Remove the level plug 1, the oil should be flush with the edge of the hole.
- If necessary, add oil (\leq LUBRICANTS AND FUEL) through the filler hole 2.
- Refit and tighten the level plug 1 (tightening torque 35 - 50 N.m).



CHECK

Front wheel reducer seals

CHECK

Rear wheel reducer seals

Place the lift truck on level ground with the engine stopped.

- Visually check for any traces of seepage or leakage from the level plug.
- If there is any leakage or seepage, check the level.
- Place level plug 1 in a horizontal position.
- Remove the level plug; the oil should be flush with the edge of the opening.
- If necessary, add oil (\leq LUBRICANTS AND FUEL) through the same hole.
- Refit and tighten the level plug (tightening torque 35 - 50 N.m).



CHECK

Brake fluid level

Place the lift truck on level ground.

⚠ IMPORTANT ⚠

If the brake fluid level is abnormal, consult your dealer.

- Open the protective casing 1 with the ignition key.
- Check tank 2. The correct level should be at the MAX. level on the tank.
- If necessary, add oil (\leq LUBRICANTS AND FUEL).
- Remove the cap 3.
- Add oil through filler port.
- Refit the cap.
- Visually check that there is no leakage in the tank and pipes.



CHECK

Boom pad slide pathways

To preserve optimum operation, the pad slide pathways should be correctly lubricated:

⚠ IMPORTANT ⚠

MANDATORY GREASING OF THE BOOM AFTER:

Cleaning the boom, especially after using high pressure cleaner.

The forklift has been unused for a long period of time.

- Fully extend the boom.
- Check the condition of the surface of the pad slide pathways, surface run in (steel whitened) without traces of corrosion.
- If necessary lubricate the pad slide pathways (\leq LUBRICANTS AND FUEL).
- Telescope the boom several times in order to spread the lubricant evenly.
- Remove the surplus lubricant.

⚠ IMPORTANT ⚠

If the lift truck is used in an abrasive environment (dust, sand, and coal), use lubricating varnish (MANITOU Part No: 483536). Consult your dealer.



CHECK

Hydraulic fluid level

Place the lift truck on level ground with the engine stopped, and the boom retracted and lowered as far as possible.

⚠ IMPORTANT ⚠

Use a very clean funnel and clean the top of the oil can before filling.

- Check dipstick 1, the correct level must be at the level of the red dot.
- If necessary, add oil (↔ LUBRICANTS AND FUEL).
- Remove the lock 2 of the filler cap 3.
- Add oil through filler port.
- Refit the cap and its lock.
- Visually check that there is no leakage in the tank and pipes.



CHECK

Windshield washer fluid level

- Visually check the level in tank 1.
- If necessary, add windshield washer fluid (↔ LUBRICANTS AND FUEL).
- Remove the cap 2.
- Add windshield washer liquid through filler port.
- Refit the cap.



CLEAN

Fuel pre-filter

⚠ IMPORTANT ⚠

Carefully clean the outside of the pre-filter and its holder, to prevent dust from getting into the system.

- Open the engine hood.
- Disconnect electrical wiring harness 1 from the fuel pre-filter.
- Place a receptacle under the drain plug 2 and unscrew it by two thread turns.
- Allow the diesel fuel to flow out until it is free from impurities and water.
- Retighten drain plug 2 and reconnect the wiring harness 1.



CLEAN

Radiator cores

⚠ IMPORTANT ⚠

In a polluting atmosphere, clean the radiator cores every day. Do not use a water jet or high pressure steam as this could damage the fins.

- Open the engine hood.
- If necessary, clean the intake grille on the engine cover.
- Using a soft cloth, clean the radiator cores in order to remove as much dirt as possible.
- Clean the radiator using a compressed air jet aimed from the engine toward the radiator, in the opposite direction to the cooling air flow.



CLEAN

Dry air filter cartridge

Prefiltration elements are available for use in very dusty conditions (⇐ FILTER CARTRIDGES AND BELTS). The cartridge checking and cleaning interval must also be reduced.

⚠ IMPORTANT ⚠

If the clogging indicator lamp comes on, this operation should be performed as soon as possible (maximum 1 hour). Never operate the lift truck without an air filter or with an air filter that is damaged.

Maintain a safety distance of 30 mm between the jet of air and the cartridge to avoid tearing or piercing the cartridge. The cartridge must not be blown through close to the air filter casing. Never clean the cartridge by tapping it on a hard surface. Protect your eyes during this operation.

Do not clean the dry air filter cartridge by washing it in liquid. Never clean the safety cartridge located inside the filter cartridge. Change it for a new one if it is clogged or damaged.

- For the dismantling and refitting of the cartridge (⇐ 1000H: REPLACE Air filter cartridge).
- Clean the filter cartridge using a compressed air jet (max. pressure 3 bars) directed from the top to the bottom and from the inside toward the outside at a minimum distance of 30 mm from the cartridge wall.
- Cleaning is completed when there is no more dust on the cartridge.
- Clean the cartridge seal surface with a damp, clean, lint-free cloth and grease with a silicone lubricant (MANITOU Part No.: 479292).
- Visually inspect the external condition of the air filter and its mounts. Check also the condition of the hoses and their attachments.

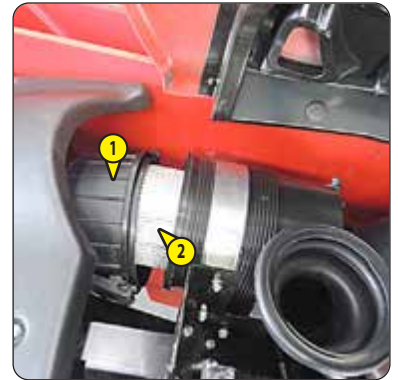

CLEAN

Condenser harness (Air conditioning OPTION)

⚠ IMPORTANT ⚠

In a polluting atmosphere, clean the radiator harness daily. Do not use a water jet or high-pressure steam as this could damage the condenser fins.

- Remove the protective grid 1 and clean it if necessary.
- Visually check whether the condenser is clean and clean it if necessary.
- Clean the condenser using a compressed air jet aimed in the same direction as the air flow.
- Clean with the fans running for best results.



To be carried out weekly, if the lift truck has been operated for less than 50 hours during the week.

⚠ IMPORTANT ⚠

In the event of prolonged use in an extremely dusty or oxidizing atmosphere, reduce this interval to 10 hours of service or every day.

Clean, then lubricate the following points with grease (← LUBRICANTS AND FUEL) and remove the surplus.

BOOM

- 1 - Lubricators of the boom pin (2 lubricators).
- 2 - Lubricator of the carriage pin (1 lubricator).
- 3 - Lubricator of the tilting cylinder foot pin (1 lubricator).
- 4 - Lubricator of the tilting cylinder head pin (1 lubricator).
- 5 - Lubricator of the lifting cylinder foot pin (1 lubricator).
- 6 - Lubricator of the lifting cylinder head pin (1 lubricator).
- 7 - Lubricator of the compensating cylinder foot pin (1 lubricator).
- 8 - Lubricator of the compensating cylinder head pin (1 lubricator).

FRONT AND REAR WHEEL REDUCTION GEAR PIVOTS

- 9 - Lubricators of the wheel reduction gear pivot pins (8 lubricators).

REAR AXLE OSCILLATION

- 10 - Rear axle oscillation lubricators (2 lubricators).

BLOCKING REAR AXLE OSCILLATION

- 11 - Oscillation blocking cylinder foot pin lubricator (1 lubricator).
- 12 - Oscillation blocking cylinder head pin lubricator (1 lubricator).



REPLACE

Engine oil *

REPLACE

Engine oil filter *

Place the lift truck on level ground, let the engine run at idle for a few minutes, then stop the engine.

⚠ IMPORTANT ⚠

*Dispose of the used oil in an ecological manner.
Hand-tighten the oil filter and lock in place with a quarter turn.*

DRAINING THE OIL

- Open the engine hood.
- Remove access panel 1.

N.B.: When removing cover plates and hatches, clean the surrounding area and remove any accumulations of flammable materials.

- Place a container under the drain hole and unscrew the drain plug 2.
- Remove the filler plug 3 to ensure correct drainage.

REPLACEMENT OF THE FILTER

- Unscrew and discard the engine oil filter 4, together with its seal.
- Clean the filter bracket with a clean, lint-free cloth.
- Lightly oil the seal before refitting the new oil filter (⇐ FILTER CARTRIDGES AND BELTS) on its bracket (tightening torque 15 - 17 N.m).

FILLING WITH OIL

- Refit and tighten the drain plug 2 (tightening torque 44.1 - 53.9 N.m).
- Fill up with oil (⇐ LUBRICANTS AND FUEL) through filler hole 5.
- Wait a few minutes to allow the oil to flow into the sump.
- Start the engine and let it run for a few minutes.
- Check for possible leaks from the drain plug and the oil filter.
- Stop the engine, wait a few minutes and check the correct level between the two marks on the dipstick 6.
- Top up the level, if necessary.
- Refit the access cover 1.

** Only for the first 50 hours of service and then every 500 hours of service or 1 year.*

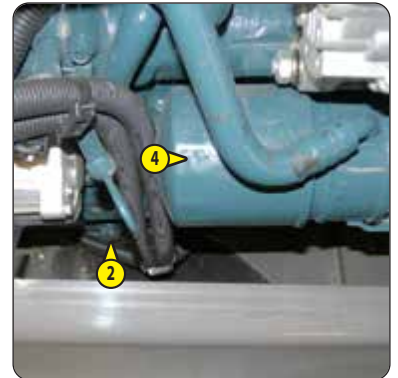

CHECK

Hydraulic oil

MANITOU offers a hydraulic fluid analysis kit which might make it possible to delay the recommended deadline in the periodic maintenance schedule (2,000 hours). In this case we recommend an analysis of the hydraulic oil every 500 hours or 1 year of service.

The oil analysis kit also makes it possible to confirm the oil quality so as to obtain a deadline of 2,000 hours for specific uses causing constraints on the hydraulic circuit: extreme environmental conditions, use of the attachments with a very high hydraulic flow rate (such as a sweeper, or a concrete mixer).

- Order an oil analysis kit from your dealer.
- Upon receiving the kit, take a sample of oil and follow the instructions shown on the kit.
- According to the results, keep the analysis report or replace the hydraulic fluid.

Oil analysis kit MANITOU Part No.: 958162.



REPLACE

Engine oil

REPLACE

Engine oil filter

Place the lift truck on level ground, let the engine run at idle for a few minutes, then stop the engine.



*Dispose of the used oil in an ecological manner.
Hand-tighten the oil filter and lock in place with a quarter turn.*

DRAINING THE OIL

- Open the engine hood.
- Remove access panel 1.
- N.B.: When removing cover plates and hatches, clean the surrounding area and remove any accumulations of flammable materials.
- Place a container under the drain hole and unscrew the drain plug 2.
- Remove the filler plug 3 to ensure correct drainage.

REPLACEMENT OF THE FILTER

- Unscrew and discard the engine oil filter 4, together with its seal.
- Clean the filter bracket with a clean, lint-free cloth.
- Lightly oil the seal before refitting the new oil filter (◀ FILTER CARTRIDGES AND BELTS) on its bracket (tightening torque 15 - 17 N.m).

FILLING WITH OIL

- Refit and tighten the drain plug 2 (tightening torque 44.1 - 53.9 N.m).
- Fill up with oil (◀ LUBRICANTS AND FUEL) through filler hole 5.
- Wait a few minutes to allow the oil to flow into the sump.
- Start the engine and let it run for a few minutes.
- Check for possible leaks from the drain plug and the oil filter.
- Stop the engine, wait a few minutes and check the correct level between the two marks on the dipstick 6.
- Top up the level, if necessary.
- Refit the access cover 1.

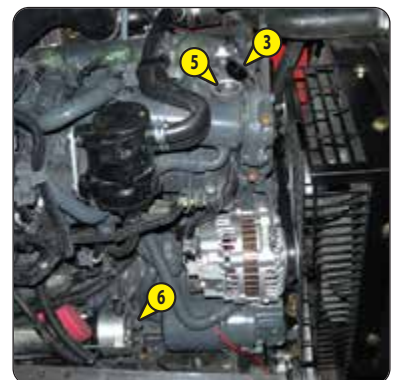
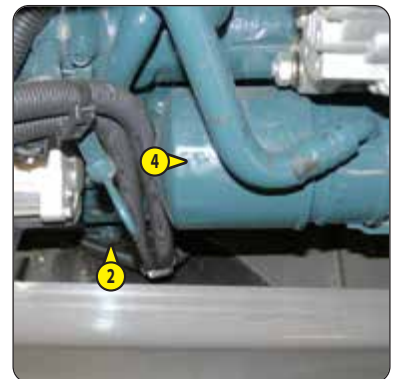

REPLACE

Fuel filter

⚠ IMPORTANT ⚠

*Carefully clean the outside of the filter and around it, to prevent dust from getting into the system.
Tighten the filter by hand only and lock it by a quarter turn.*

- Switch off the lift truck's ignition with the ignition key.
- Unscrew the filter 1.
- Clean the inside of the filter head using a brush immersed in clean diesel oil.
- Refit a new filter lubricated with clean diesel beforehand (⇐ FILTER CARTRIDGES AND BELTS).



REPLACE

Fuel pre-filter

⚠ IMPORTANT ⚠

*Carefully clean the outside of the filter and around it, to prevent dust from getting into the system.
Tighten the filter by hand only and lock it by a quarter turn.*

- Disconnect the wiring harness 1.
- Place a receptacle under the filter 2.
- Unscrew the filter 2.
- Clean the inside of the filter head using a brush immersed in clean diesel oil.
- Refit a new filter lubricated with clean diesel beforehand (⇐ FILTER CARTRIDGES AND BELTS).
- Reconnect the wiring harness 1.
- Open bleed screws 3 and 4.
- Turn on the lift truck's ignition with the ignition key.
- Close the bleed screws 3 and 4 as soon as the diesel flows free of air.

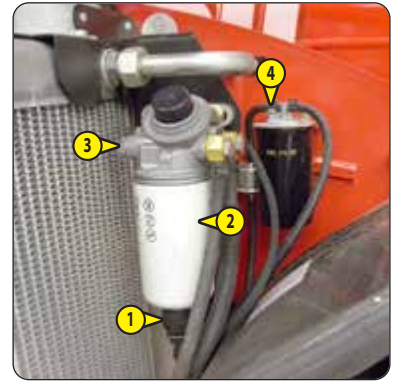

REPLACE

Transfer box oil

Place the lift truck on level ground with the engine stopped and the transfer box oil still warm.

⚠ IMPORTANT ⚠

Dispose of the used oil in an ecological manner.

- Place a container under drain plug 1 and unscrew the plug.
- Remove level and filling plug 2 to ensure correct drainage.
- Refit and tighten the drain plug 1 (tightening torque 35 - 50 N.m).
- Fill up with oil (⇐ LUBRICANTS AND FUEL) through filler hole 2.
- The level is correct when the oil level is flush with the edge of the hole.
- Check for any possible leaks at the drain plug.
- Refit and tighten the level and filling plug 2 (tightening torque 35 - 50 N.m).

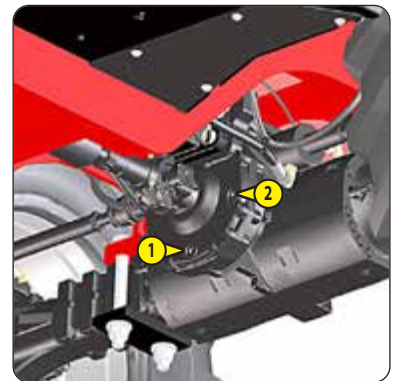

REPLACE

Front axle differential oil

Place the lift truck on level ground with the engine stopped and the still warm differential oil.

⚠ IMPORTANT ⚠

Dispose of the used oil in an ecological manner.

- Place a container under drain plug 1 and unscrew the plug.
- Remove level and filling plug 2 to ensure correct drainage.
- Refit and tighten the drain plug 1 (tightening torque 35 - 50 N.m).
- Fill up with oil (☞ LUBRICANTS AND FUEL) through filler hole 2.
- The level is correct when the oil level is flush with the edge of the hole.
- Check for any possible leaks at the drain plug.
- Refit and tighten the level and filling plug 2 (tightening torque 35 - 50 N.m).

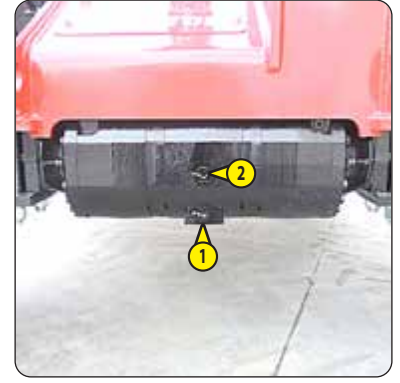

REPLACE

Hydraulic return oil filter cartridge

Stop the engine and release the pressure from the systems by operating the hydraulic controls.

⚠ IMPORTANT ⚠

Raise the boom and place the boom safety wedge on the rod of the lifting cylinder (☞ 1 - INSTRUCTIONS AND SAFETY RECOMMENDATIONS: LIFT TRUCK MAINTENANCE INSTRUCTIONS).

Thoroughly clean the outside of the filter and its surroundings before any operation to prevent any risk of polluting the hydraulic system.

- Remove the crankcase 1.
- Unscrew the cover 2.
- Slowly take out filter cartridge assembly 3 and 4.
- Wait a few seconds for the oil to flow into the container.
- Separate the head 3 from the filter cartridge 4 with a twisting motion.
- Refit the head onto a new cartridge (☞ FILTER CARTRIDGES AND BELTS).
- Fit the assembly in place and re-tighten cover 2.
- Refit the crankcase 1.

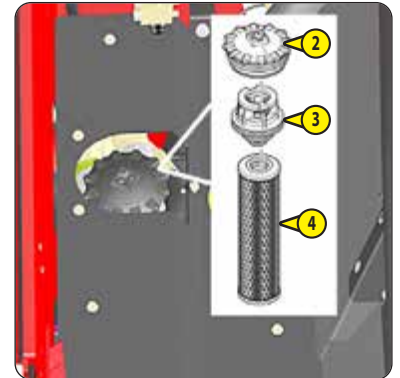

REPLACE

Hydraulic oil tank filter cap

Place the lift truck on level ground with the engine stopped.

- Remove the lock 1 on the filler cap 2.
- Unscrew the filter cap 2 and replace it with a new one (⇐ FILTER CARTRIDGES AND BELTS).
- Refit and tighten the filter cap 2 (tightening torque $3 \pm 0,5$ N.m).
- Refit the lock 1.



REPLACE

Cab fan filter

INTERNAL CAB VENTILATION FILTER

- Remove the protective grid 1.
- Remove the cab ventilation filter and replace it with a new one (⇐ FILTER ELEMENTS AND BELTS).
- Refit the protective grid.



CHECK

Hoses and differential pressure hoses for the exhaust particle filter "DPF" **

CHECK

Exhaust gas recirculation piping "EGR" **

CHECK

Intake hose **

CHECK

****Exhaust manifold**

CHECK

Fork wear *

**** Engine service, consult your dealer.**

*** Consult your dealer.**

🔄 1000H - PERIODIC MAINTENANCE - EVERY 1000 HOURS OF SERVICE OR EVERY 2 YEARS

ALSO CARRY OUT THE PERIODIC MAINTENANCE FOR 500 HOURS OF SERVICE.

CHECK

Seat belt

⚠️ IMPORTANT ⚠️

*Under no circumstances must the lift truck be used if the seat belt is defective (fixing, locking, cuts, tears, etc.).
Immediately repair or replace the seat belt.*

SEAT BELT WITH TWO ANCHORING POINTS

- Check the following points:
 - Fixing of the anchoring points on the seat.
 - Cleanness of the strap and the locking mechanism.
 - Triggering of the locking mechanism.
 - Condition of the strap (cuts, curled edges).

REELED SEAT BELT WITH TWO ANCHORING POINTS

- Check the points listed above together with the following points:
 - The correct winding of the belt.
 - Condition of the reel guards.
 - Roller locking mechanism when the strap is given a sharp tug.

N.B.: Replace the seat belt after an accident.

CLEAN

Fuel tank

REPLACE

Fuel tank breather

Place the lift truck on level ground with the engine stopped.

⚠️ IMPORTANT ⚠️

Do not smoke or approach with a flame during this operation.

Never attempt to carry out welding or any other operation by yourself, as this could cause an explosion or a fire.

- Inspect the parts of the fuel circuit and the tank liable to leak, both visually and by touch.
- In the event of a leak, contact your dealer.
- Place a container under drain plug 1 and unscrew the plug.
- Remove the filler plug 2 to ensure correct drainage.
- Rinse with ten liters of clean diesel through the filler hole 3.
- Refit and tighten the drain plug 1 (tightening torque 18 - 22 N.m).
- Unscrew the breather 4 and replace with a new one (⇐ FILTER CARTRIDGES AND BELTS) (tightening torque 5 ± 2 N.m).
- Fill the fuel tank with clean diesel filtered through the filler port.
- Refit the filler plug.

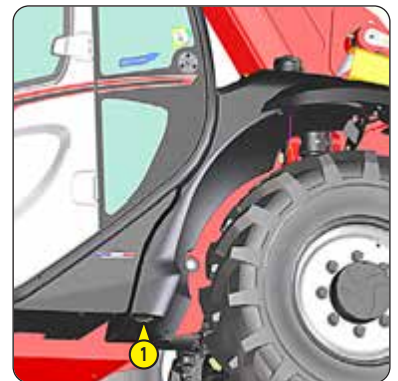

⚠ IMPORTANT ⚠

Check the belt tension again after the first 20 hours of service.

REMOVING THE BELT

- Unscrew the screws 1.
- Remove the radiator protection grille 2.
- Undo the screw 3 and swivel the radiator as far as it will go.
- Remove the fan 4, making a note of the direction.
- Undo the screws 5 and remove the assembly 6.
- Loosen screws 7 by two to three thread turns.
- Swivel the alternator assembly so as to free the belt 8.
- Remove the belt 8.

N.B.: Take the opportunity provided by the removal of the belt to check that the pulleys and bearings are working correctly (noise, friction, play, etc.).

REFITTING THE BELT

- Refit a new alternator belt (⇐ FILTER CARTRIDGES AND BELTS). Ensure that it is properly seated in the grooves of each pulley.
- Adjust the belt tension between the crankshaft pulley and the alternator pulley (98 N). The clearance should be about 7 to 9 mm.
- Swivel the alternator assembly so as to obtain the belt tension required.
- Retighten screws 7 (tightening torque 22 N.m).
- Refit the unit 6.
- Refit the fan 4.
- Swivel the radiator and replace the screw 3.
- Refit the radiator protection grill 2.

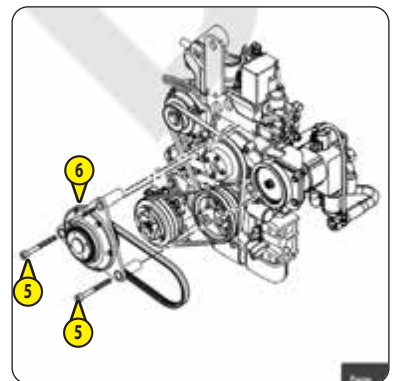
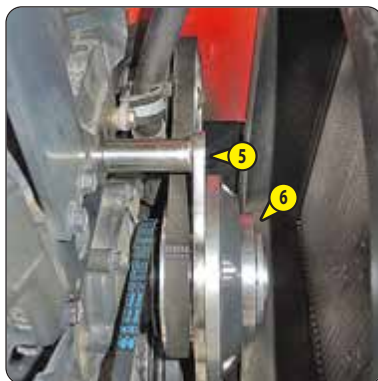
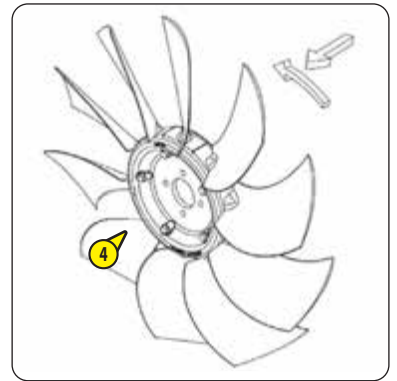
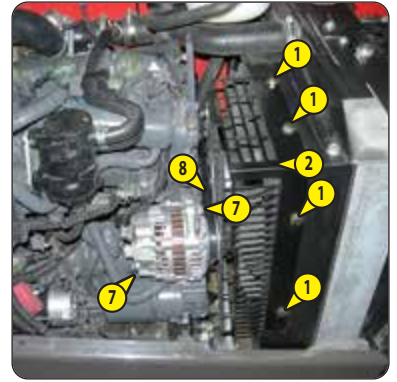

REPLACE

Engine crankcase ventilation filter

- Open the engine hood.
- Carefully clean the outside of the filter and its holder, to prevent dust from getting into the system.
- Disconnect the hose 1 at the filter.
- Unscrew the cover 2.
- Take out the filter 3 and discard it together with the seal of the cover 2.
- Refit a new seal on the cover and insert a new filter (⇐ FILTER CARTRIDGES AND BELTS).
- Tighten the cover 2 by hand only and lock in place by a quarter turn.
- Reconnect hose 1.



REPLACE

Dry air filter cartridge

Prefiltration elements are available for use in very dusty conditions (⇐ FILTER CARTRIDGES AND BELTS). Also, the checking and cleaning periodicity of the cartridge must be reduced (up to 250 hours in a very dusty atmosphere and with pre-filtration).

⚠ IMPORTANT ⚠

Change the cartridge in a clean location, with the engine stopped. Never operate the lift truck with a cartridge removed or damaged.

- Open the engine hood.
- Loosen the locks and remove cover 1.
- Gently remove the cartridge 2 to reduce dust falling as far as possible.
- Leave the safety cartridge in place.
- Carefully clean the following parts with a damp, clean lint-free cloth.
 - The inside of the filter and cover.
 - The inside of the filter inlet hose.
 - The gasket surfaces in the filter and in the cover.
- Check pipes and connections between the air filter and the engine and the connection and state of the clogging indicator on the filter.
- Before fitting check the condition of the new cartridge (⇐ FILTER CARTRIDGES AND BELTS).
- Insert the cartridge in the filter axis and push the cartridge pressing against the outer edge and not in the center.
- Reassemble the cover, guiding the valve downwards.

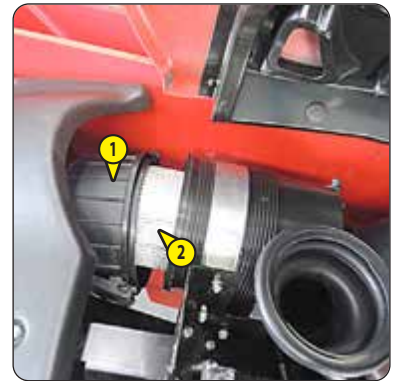

REPLACE

Coolant

These operations are to be carried out as necessary or every 2 years at the beginning of winter. Place the lift truck on level ground with the engine stopped and cold.

⚠ IMPORTANT ⚠

The engine does not contain any anti-corrosion elements and must be filled throughout the year with a mixture containing 25% ethylene glycol-based antifreeze.

DRAINING THE LIQUID

- Open the engine hood.
- Remove access panel 5.
- Place a container under the radiator drain plug 1 and unscrew the plug.
- Remove filler plug 2 from the expansion tank and fully open the heating control to ensure correct drainage.
- Let the cooling circuit drain entirely while ensuring that the ports do not get clogged.
- Check the condition of the hoses as well as the fastening devices and change the hoses if necessary.
- Rinse the circuit with clean water and use a cleaning agent if necessary.

FILLING WITH COOLANT

- Refit and tighten the radiator drain plug 1 (tightening torque 20 N.m).
- Slowly fill the circuit with coolant (⚠ LUBRICANTS AND FUEL) up to the middle of the expansion tank 3 by the filler hole 4.
- Refit the filler plug 2.
- Run the engine at idle for a few minutes.
- Check for any possible leaks.
- Check the level and top up if necessary.



REPLACE

Rear axle differential oil

Place the lift truck on level ground with the engine stopped and the still warm differential oil.

⚠ IMPORTANT ⚠

Dispose of the used oil in an ecological manner.

- Place a container under drain plug 1 and unscrew the plug.
- Remove level and filling plug 2 to ensure correct drainage.
- Refit and tighten the drain plug 1 (tightening torque 35 - 50 N.m).
- Fill up with oil (⚠ LUBRICANTS AND FUEL) through filler hole 2.
- The level is correct when the oil level is flush with the edge of the hole.
- Check for any possible leaks at the drain plug.
- Refit and tighten the level and filling plug 2 (tightening torque 35 - 50 N.m).

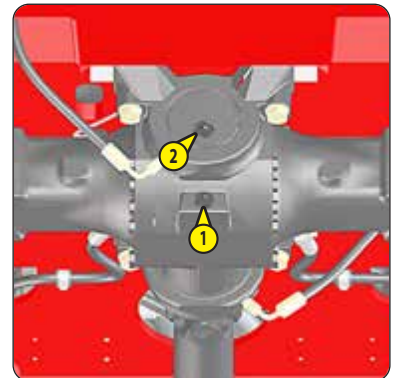

REPLACE

Front wheel reducer oil

REPLACE

Rear wheel reducer oil

Place the lift truck on level ground with the engine stopped and the reducers' oil still warm.

⚠ IMPORTANT ⚠

Dispose of the used oil in an ecological manner.

- Drain and change the oil of each wheel reduction gear.
- Place drain plug 1 in position A.
- Place a container under the drain plug and unscrew the plug.
- Let the oil drain fully.
- Place the drain port in position B, i.e. in a level port.
- Fill up with oil (⚠ LUBRICANTS AND FUEL) through level hole 1.
- The level is correct when the oil level is flush with the edge of the hole.
- Refit and tighten the drain plug (tightening torque 35 - 50 N.m).



CHECK

Silentblocks **

CHECK

Valve lash **

CHECK

Injectors **

CHECK

Exhaust gas recirculation cooler "EGR" **

CHECK

Casing gas recycling valve **

CHECK

Rear axle locking cylinder *

CHECK

Brake system pressure *

CHECK

Boom pad wear *

CHECK

Condition of wiring harnesses and cables *

CHECK

Lights and signals *

CHECK

Warning indicators *

CHECK

Condition of the rear view mirrors *

CHECK

Cab structure *

CHECK

Chassis structure *

CHECK

Attachment mounting system *

CHECK

Condition of attachments *

REPLACE

Brake fluid *

BLEED

Rear axle locking cylinder *

BLEED

Braking system *

ADJUST

Brake *

**** Engine service, consult your dealer.**

*** Consult your dealer.**

🔄 2000H - PERIODIC MAINTENANCE - EVERY 2000 HOURS OF SERVICE OR EVERY 4 YEARS

ALSO PERFORM THE 500 HOUR AND 1000 HOUR PERIODIC MAINTENANCE.

CHECK

Wheel nut tightening torque

- Check the condition of the tires, to detect cuts, blisters, wear, etc.
- Check the tightening torque of the wheel nuts with a torque wrench.
 - Front wheels: 630 N.m \pm 94 N.m
 - Rear wheels: 630 N.m \pm 94 N.m

REPLACE

Dry air filter safety cartridge

⚠ IMPORTANT ⚠

The safety cartridge replacement frequency is given for information only. It must be changed every second time the dry air filter cartridge is changed.

- For dismantling and reassembly of the cartridge ($\leq 1,000$ HOURS: REPLACE Air filter cartridge).
- Carefully remove the dry air filter safety cartridge 1 to reduce dust fall as much as possible.
- Clean the gasket surface on the filter with a damp, clean lint-free cloth.
- Check the condition of the new safety cartridge before fitting (\leq FILTER CARTRIDGES AND BELTS).
- Insert the cartridge in the filter axis and push the cartridge pressing against the outer edge and not the center.

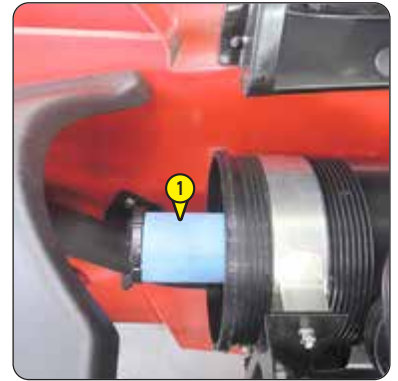

REPLACE

Hydraulic oil

CLEAN

Hydraulic fluid tank suction strainers

REPLACE

Brake accumulator unit filter

Place the lift truck on level ground with the engine shut down and the boom retracted and lowered as far as possible.

⚠ IMPORTANT ⚠

Before any intervention, thoroughly clean the area surrounding the filter, the drain plugs and the suction cover on the hydraulic tank.

Dispose of the used oil in an ecological manner.

Use a clean container and funnel and clean the underside of the oil drum before filling.

DRAINING THE OIL

- Place a container under drain plugs 1 and unscrew them.
- Remove the filler cap lock 2
- Remove the filler plug 3 to ensure correct drainage.

CLEANING OF STRAINERS

- Remove hose 4.
- Remove and clean the suction strainer 5 using a compressed air jet, check its condition and replace if necessary (↩ FILTER CARTRIDGES AND BELTS).
- Refit the strainer 5 and hose 4 making sure the seal is in the correct position.

REPLACING THE BRAKE ACCUMULATOR UNIT FILTER

- Unscrew plug 6, remove and replace the filter with a new one (↩ FILTER CARTRIDGES AND BELTS).
- Refit and tighten the plug 6 (tightening torque 47 - 53 N.m).

FILLING WITH OIL

- Clean and refit the drain plugs 1 (tightening torque 51 - 69 N.m).
- Fill up with oil (↩ LUBRICANTS AND FUEL) through filler hole 7.
- Observe the oil level on dipstick 8, the oil level should be at the level of the red dot.
- Check for any possible leaks at the drain plugs.
- Refit the filler cap 3 and its lock 2.

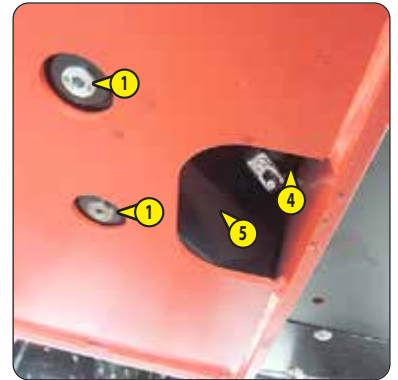
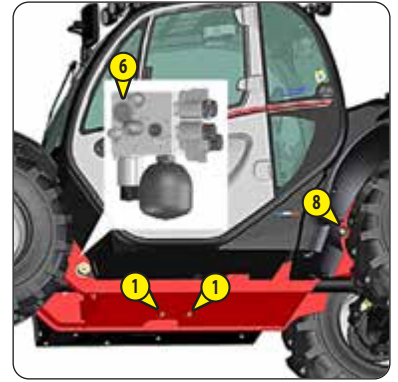

CHECK	Radiator *
CHECK	Transmission pressures *
CHECK	Steering *
CHECK	Steering swivel joints *
CHECK	Brake pad and brake disk wear *
CHECK	Condition of boom assembly *
CHECK	Bearings and bushings *
CHECK	Condition of hoses and flexible pipes *
CHECK	Condition of cylinders (leakage, rods) *
CHECK	Hydraulic circuit pressures *
CLEAN	Air conditioning (OPTION) *

CLEANING CONDENSER AND EVAPORATOR COILS

CLEANING CONDENSATE TRAY AND RELIEF VALVE

COLLECTING COOLANT TO REPLACE DRIER FILTER

REFILLING WITH COOLANT AND CHECKING THE THERMOSTATIC CONTROL AND PRESSURE SWITCHES

N.B.: When opening the evaporator unit, remember to replace the cover seal.



NEVER TRY TO REPAIR ANY FAULTS YOURSELF. WHEN REFILLING CIRCUITS, ALWAYS REFER TO A DEALER WHO HAS THE CORRECT SPARE PARTS AND THE TECHNICAL KNOWLEDGE AND TOOLS REQUIRED.

In any of the following circumstances, call a doctor.

If inhaled, take the victim to fresh air.

If there is contact with the skin, wash immediately with plenty of water.

If there is frostbite, apply a sterile dressing.

If there is contact with the eyes, rinse with clear water for 15 minutes.

IMPORTANT INFORMATION REGARDING THE COOLANT USED

- This product contains fluorinated greenhouse gases covered by the Kyoto Protocol.
- Coolant type: R134A; it is colorless and odorless and heavier than air. Its GWP (Global Warming Potential) is 1430.
- Do not allow the gases to escape into the atmosphere. Do not open the system under any circumstances, as this could cause refrigerant to escape.
- The compressor has a fluid level gage; never unscrew this gage because it would depressurize the system. The fluid level should only be checked when draining the system.

REPLACE	Compressor belt (Air Conditioning OPTION) *
----------------	--

** Consult your dealer.*

➔ ④ 3000H - PERIODIC MAINTENANCE - EVERY 3,000 HOURS OF SERVICE OR EVERY 6 YEARS

ALSO PERFORM THE 500 HOUR AND 1000 HOUR PERIODIC MAINTENANCE.

CHECK

Turbocharger **

CHECK

Exhaust gas recirculation system "EGR" **

CLEAN

Exhaust particle filter "DPF" **

**** Engine service, consult your dealer.**

CLEAN

Lift truck

Clean any traces of fuel, oil or grease from the lift truck or at least the area in question before carrying out any work.

EXTERIOR WASHING

- Close and lock all accesses to the lift truck (doors, windows, cowls, etc.).
- When washing with a high pressure cleaner, avoid the hinges and electrical components and connections.
- If necessary, protect components susceptible to damage, particularly electrical components and connections and the exhaust outlet, against penetration of water, steam or cleaning agents.
- After washing, leave the lift truck to dry in the open air and do not park inside a building.

INTERIOR WASHING

- Avoid cleaning the engine, the harnesses, the electrical components and parts with sensitive seals (e.g. universal joint cross-piece) with a high pressure cleaner. Clean with compressed air instead.
- Clean any accumulation of flammable materials near to heat sources and electrical components.
- Special attention should be paid to all the areas of the lift truck where these high-risk materials are likely to accumulate (e.g. engine compartment, under the boom, above the axles, etc.).

⚠ IMPORTANT ⚠

Exhaust regeneration is an automated procedure activated by the operator when the following indicator lamps are displayed:

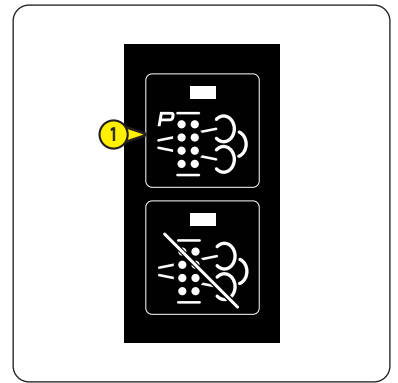

- Park the lift truck in a safe and adequately ventilated place.
- Check the following points:
 - forward/reverse selector in neutral,
 - parking brake applied,
 - boom angle less than 5°,
 - accelerator pedal released,
 - hand throttle not used (option),
- Check that the fuel level is sufficient.
- Start the lift truck and run the engine for a few minutes to bring it up to its operating temperature.
- Press the top of the switch (1) for more than two seconds to begin the regeneration procedure.
- Lighting of the indicator lamp plus a beep conforms the start of the "stationary lift truck" exhaust regeneration procedure.
- The "wait" display will flash throughout the "stationary lift truck" exhaust regeneration.
- Otherwise, "notice" will be displayed for 3 seconds indicating a fault in the procedure. In this event check the positioning of the lift truck and contact your dealer if necessary.
- At the end of the procedure, indicator lamps + go out.
- During the procedure, the engine speed increases to approx. 1,800 rpm, and the indicator lamp comes on when the exhaust particle filter gases reach a high temperature.

⚠ IMPORTANT ⚠

The exhaust regeneration procedure must only be stopped if absolutely necessary.

The procedure stops automatically if the operator:

- activates the hydraulic control joystick,
- engages forward or reverse gear,
- switches off the engine,
- or pressing on the top of the switch 1.

- The time taken for exhaust regeneration varies (between 15 and 30 minutes) according to several criteria, such as:
 - the level of clogging of the filter,
 - the ambient temperature,
 - the fuel quality and type of engine oil,
 - the number of exhaust particle filter automatic regeneration requests previously canceled.
- The engine will return to its initial idling speed to indicate that the procedure has finished.

⚠ IMPORTANT ⚠

Once the exhaust regeneration procedure is completed, leave the engine idling for a few minutes to lower the temperature before switching off the ignition.

REPLACE

Wheels

For this operation, we recommend using the hydraulic jack (MANITOU Part No.: 505507) and the safety strut (MANITOU Part No.: 554772).

⚠ IMPORTANT ⚠

In the event of a wheel being changed on the public highway, secure the lift truck vicinity:

- Stop the lift truck, if possible on firm, level ground.
- Stop the lift truck (☞ 1 - SAFETY INSTRUCTIONS: DRIVING INSTRUCTIONS UNLADEN AND LADEN).
- Switch on the hazard warning lights.
- Immobilize the lift truck in both directions on the axle opposite to the wheel to be changed.
- Unlock the nuts of the wheel to be changed.
- Place the jack under the flared axle tube, as near as possible to the wheel, and adjust the jack.
- Raise the wheel until it is clear of the ground and place the safety support under the axle.
- Completely unscrew the wheel nuts and remove them.
- Free the wheel using back and forth movements and roll it to the side.
- Slip the new wheel on the wheel hub.
- Hand-tighten the nuts, grease them if necessary.
- Remove the safety support and lower the lift truck with the jack.
- Tighten the wheel nuts to the prescribed torque value (☞ 2000H - PERIODIC MAINTENANCE - EVERY 2,000 HOURS OF SERVICE OR EVERY 4 YEARS) using a torque wrench.



ADJUST

Front headlights

RECOMMENDED SETTING

(as per standard ECE-76/756 76/761 ECE20)

Adjustment of -2 % of the dipped beam harness relative to the horizontal axis of the headlight.

ADJUSTMENT PROCEDURE

- Place the unladen lift truck in the transport position and perpendicular to a white wall on flat, level ground.
- Check the tire pressures (☞ 2 - DESCRIPTION: TIRES).
- Put the gearshift lever in neutral.

CALCULATING THE HEIGHT OF THE DIPPED BEAM (H2)

- h_1 = Height of the dipped beam in relation to the ground.
- h_2 = Height of the adjusted beam.
- l = Distance between the dipped beam and the white wall.

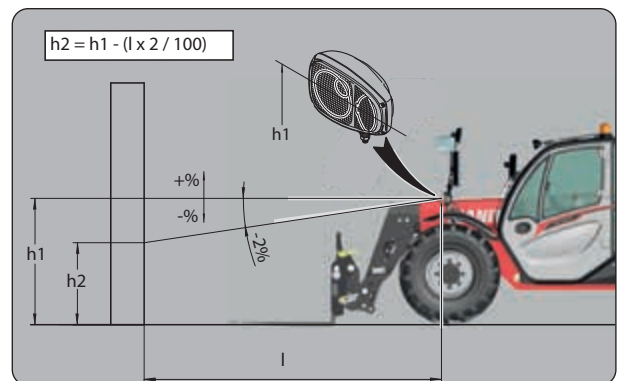

According to the use of the lift truck, the device may need to be periodically reset.



This operation can be easily performed by means of the following procedure.

- Provide a fork carrier or a bucket and a load corresponding to at least half the lift truck's rated capacity.
- Preferably perform the reset when the lift truck is still cold (before it is used) or ensure that the temperature of the rear axle is not more than 50 °C.



⚠ IMPORTANT ⚠

Carefully follow the boom positioning instructions.

*When the reset is completed, check the operation of the longitudinal stability limiter and warning device (⚡ 10H - DAILY MAINTENANCE OR EVERY 10 HOURS OF SERVICE).
If in doubt, consult your dealer.*

- Place the lift truck on flat, level ground with the wheels straight.
- Press the button  to display the "PREFERENCES" menu.
- Press the button  to select from the menus and sub-menus.



- Press knob  to confirm.
- Follow the steps described on the information screen (OK = press button ).

⚠ IMPORTANT ⚠

*If the lift truck is not on level ground, chock it so that it does not descend the slope.
The lift truck must be towed very slowly (less than 5 km/h) and for as short a distance as possible (less than 100 m).*

For towing a lift truck, the high pressure limiters must be unlocked to avoid damaging the hydrostatic transmission, and the parking brake on the front axle must be released.

- Switch on lift truck ignition.
- Set the forward/reverse selector to neutral.
- Release the hand brake.

PUT THE FRONT AXLE IN FREEWHEEL

- Locate the four screws 1 to the left and right on the front axle.
- Loosen the four locknuts 2 by approximately 8 mm.
- Do up the screws 1 by hand until there is resistance.
- Tighten the two screws on the left alternately by a quarter turn each time until you have done a complete turn.

Tighten the two screws on the right alternately by a quarter turn each time until you have done a complete turn.

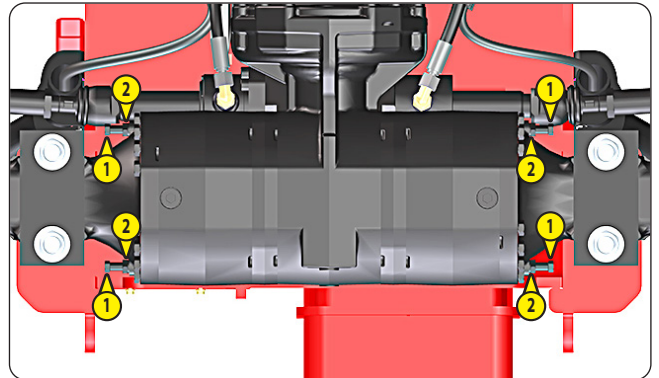

UNLOCKING THE HIGH PRESSURE LIMITERS

- Open the engine hood.
- Loosen nuts 3 on the hydrostatic pump by no more than three turns.



TOWING

- Switch on the hazard warning lights.
- Since there will be no power steering or hydraulic brake assistance, operate the steering and controls slowly and forcefully. Avoid sudden or jerky movements.
- After towing, re-tighten nuts 1 (tightening torque 70 N.m).
- Unscrew the screws 2, refit the shims 3 and re-tighten the screws 2 (tightening torque 95 - 115 N.m).

PUT THE BRAKES BACK INTO ACTION ON THE REAR AXLE

- Undo the two screws on the left alternately by a quarter turn each time until you have done a complete turn.
- Undo the two screws on the right alternately by a quarter turn each time until you have done a complete turn.
- Completely undo the four screws 1.
- Replace the seals 7.
- Lubricate the screws 1 with MANITOU BLACK MULTIPURPOSE GREASE (← LUBRICANTS AND FUEL) and put them back in place.
- Adjust the distance between the body of the axle and the screw heads = 34 mm ±0.5 mm.
- Tighten the four locknuts 2 and check the distances between the body of the axle and the screw heads.
- Check that the automatic parking brake is working correctly.

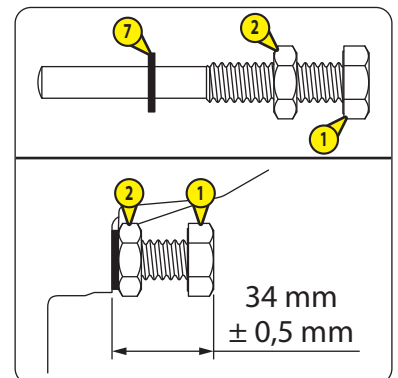

SLING

Lift truck

- Take into account the position of the lift truck center of gravity for lifting.

A = 1040 mm B = 1650 mm MT 730 ...

A = 1,535 mm B = 1,275 mm MT 930 ...

Place the hooks in the fastening points 1 provided.

⚠ IMPORTANT ⚠
Do not use the anchoring points 2

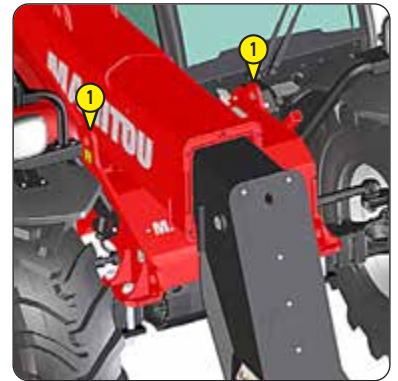
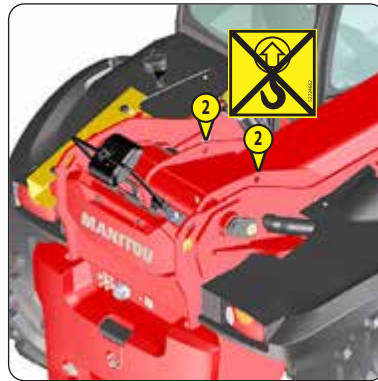
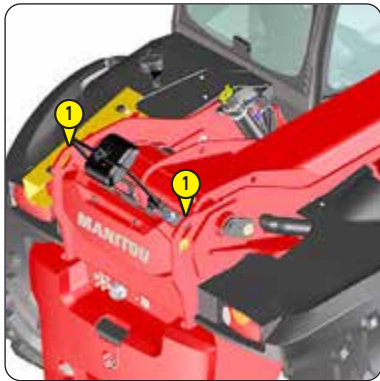
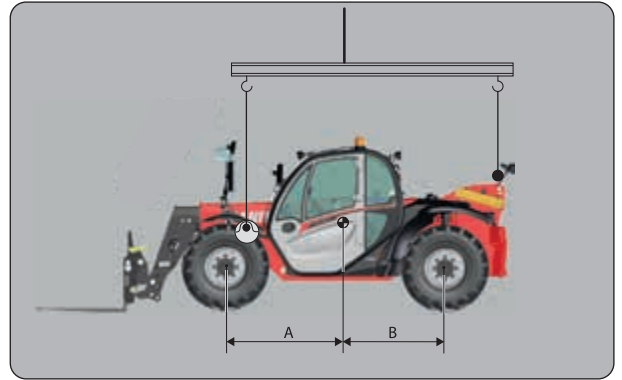

⚠ IMPORTANT ⚠

Check that the safety instructions associated with the transport vehicle have been correctly applied before loading the machine and ensure that the driver of the vehicle has been informed of the dimensional characteristics and total weight of the machine.

Ensure that the transport vehicle has adequate dimensions and load capacity for transporting the machine, \triangleleft SPECIFICATIONS and STICKERS.

Covers must be closed and locked while the machine is being transported.

⚠ IMPORTANT ⚠

The transport vehicle must be parked on a level surface and the wheels must be chocked to prevent it from rolling during loading and unloading of the machine.

For machines equipped with a turbo-charged engine, block off the exhaust outlet to avoid rotation of the turbo shaft without lubrication when transporting the vehicle.

The machine must be loaded or unloaded using a winch if the loading ramps are slippery, \triangleleft FREEWHEELING FOR TOWING/WINCHING.

The angle of the loading ramps must not exceed the maximum slope accessible value, \triangleleft SPECIFICATIONS.

The machine must be loaded and unloaded using a crane if the angle of the loading ramps exceeds the maximum slope accessible value, \triangleleft TRANSPORT FOR WINCHING: LIFTING INSTRUCTIONS.

LOADING THE MACHINE ONTO THE TRANSPORT VEHICLE

- Fully retract the telescopic arm.
- Load the machine parallel to the transport vehicle.
- Place the attachment flat on the ground.
- Activate the parking brake.
- Switch off the machine.
- Remove the ignition key.

SECURING THE MACHINE TO THE TRANSPORT VEHICLE

- Fix chocks to the transport vehicle at the front and rear of each of the machine's wheels.
- Fix chocks to the transport vehicle on the inner side of each of the machine's wheels.
- Attach the straps to the machine's anchoring points, \triangleleft STICKERS: ANCHORING POINT.
- Secure the machine, observing the lashing angles (α) and (β) and the resistance (LC) of the straps.

UNLOADING THE MACHINE FROM THE TRANSPORT VEHICLE

- Remove the straps.
- Remove the chocks from the wheels.
- Switch on the machine.
- Raise the telescopic arm.
- Release the parking brake.
- Lower the machine parallel to the transport vehicle.

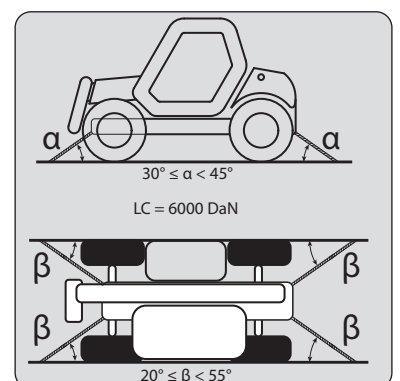
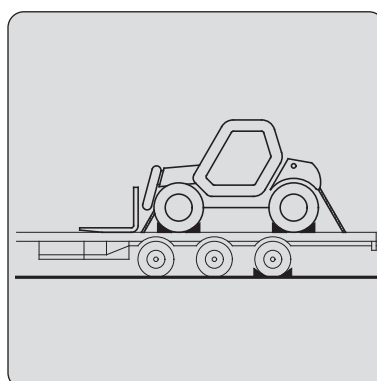
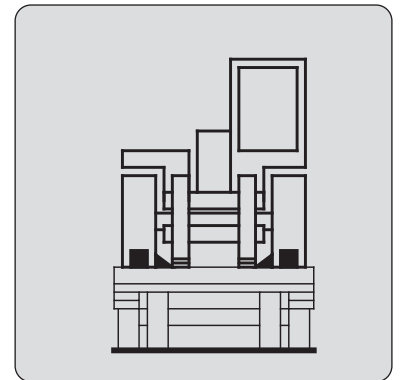
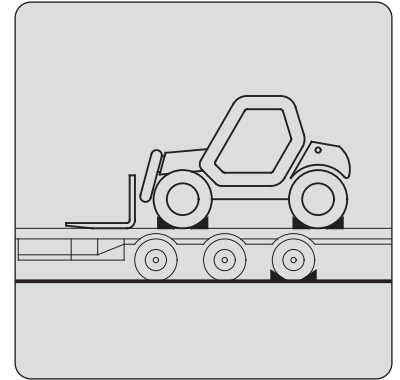

4 - ATTACHMENTS THAT CAN BE ADAPTED TO THE RANGE

4 - ATTACHMENTS THAT CAN BE ADAPTED TO THE RANGE

INTRODUCTION	4-3
PICKING UP THE ATTACHMENTS	4-4
TECHNICAL SPECIFICATIONS OF ATTACHMENTS	4-6
ATTACHMENT GUARDS	4-12

INTRODUCTION

- Your lift truck must be used with interchangeable equipment. These items are called: ATTACHMENTS.
- A wide range of attachments is available, guaranteed by MANITOU and designed to fit your lift truck perfectly.

⚠ IMPORTANT ⚠

*Only attachments approved by MANITOU can be used on its lift trucks (↪ TECHNICAL SPECIFICATIONS OF ATTACHMENTS).
The manufacturer cannot be held responsible for any modifications or adaptations to attachments without its knowledge.*

- The attachments are delivered with a load chart concerning your lift truck. The operator's manual and the load chart should be kept in the places provided in the lift truck. For standard attachments, their use is governed by the instructions contained on this notice.

⚠ IMPORTANT ⚠

*Maximum loads are defined by the capacity of a lift truck taking account of the attachment's weight and center of gravity.
Should the attachment have a lower capacity than the lift truck, never exceed this limit.*

- Some particular uses require the adaptation of the attachment which is not provided in the price-listed options. Solutions exist, consult your dealer.

⚠ IMPORTANT ⚠

Depending on their size, certain attachments may, when the boom is lowered and retracted, come into contact with the front tires and cause damage to them if excavation is activated in the direction of the discharge.

TO PREVENT THIS RISK, EXTEND THE TELESCOPE TO A SUFFICIENT EXTENT FOR THE PARTICULAR LIFT TRUCK AND ATTACHMENT SO THAT THIS CONTACT IS NOT POSSIBLE.

SUSPENDED LOAD

⚠ IMPORTANT ⚠

Suspended loads MUST be handled with a lift truck designed for that purpose (↪ 1 - OPERATING AND SAFETY INSTRUCTIONS: INSTRUCTIONS FOR HANDLING LOADS: H PICKING UP AND PUTTING DOWN A SUSPENDED LOAD).

PICKING UP THE ATTACHMENTS

1 - ATTACHMENT WITHOUT HYDRAULICS AND HAND LOCKING DEVICE

FITTING AN ATTACHMENT

- Ensure that the attachment is in a position facilitating the locking to the carriage. If it is not correctly oriented, take the necessary precautions in order to move it safely.
- Check that the locking pin is in position in the bracket (Fig. A).
- Place the lift truck with the boom lowered in front of and parallel to the attachment, and tilt the carriage forward (Fig. B).
- Bring the carriage under the locking tube of the attachment, slightly raise the boom, tilt the carriage backward in order to position the attachment (Fig. C).
- Lift the attachment off the ground to facilitate locking.

MANUAL LOCKING

- Take the locking pin on the bracket (Fig. A) and lock the attachment (Fig. D). Do not forget to fit the pin.

MANUAL UNLOCKING

- Proceed in the reverse order to MANUAL LOCKING, taking care to refit the locking pin in the bracket (Fig. A).

REMOVING THE ATTACHMENT

- Proceed in the reverse order to FITTING AN ATTACHMENT, taking care to store the attachment flat on the ground and in the closed position.

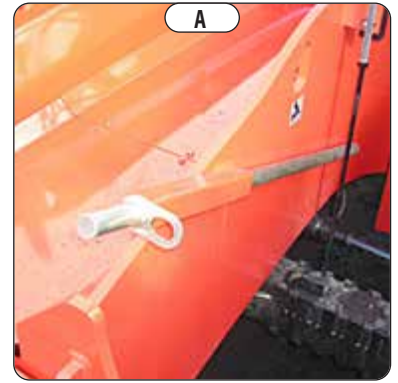

2 - HYDRAULIC ATTACHMENT AND MANUAL LOCKING DEVICE

FITTING AN ATTACHMENT

- Ensure that the attachment is in a position facilitating the locking to the carriage. If it is not correctly oriented, take the necessary precautions in order to move it safely.
- Check that the locking pin is in position in the bracket (Fig. A).
- Place the lift truck with the boom lowered in front of and parallel to the attachment, and tilt the carriage forward (Fig. B).
- Bring the carriage under the locking tube of the attachment, slightly raise the boom, tilt the carriage backward in order to position the attachment (Fig. C).
- Lift the attachment off the ground to facilitate locking.

MANUAL LOCKING AND CONNECTION OF THE ATTACHMENT

⚠ IMPORTANT ⚠

Make sure that the rapid connectors are clean and protect the holes which are not used, with the caps provided.

- Take the locking pin on the bracket and lock the attachment (fig. D). Do not forget to fit the pin.
- Stop the engine and keep the ignition on the lift truck.
- Release the pressure in the attachment hydraulic circuit by operating switch 1 on the distributor lever backwards and forwards 4 or 5 times.
- Connect the quick-release couplers according to the logic of the attachment's hydraulic movements.

MANUAL RELEASE AND DISCONNECTION OF THE ATTACHMENT

- Proceed in the reverse order of paragraph MANUAL LOCKING AND CONNECTION OF THE ATTACHMENT, taking care to refit the locking pin in the bracket.

REMOVING THE ATTACHMENT

- Proceed in the reverse order to FITTING AN ATTACHMENT, taking care to store the attachment flat on the ground and in the closed position.

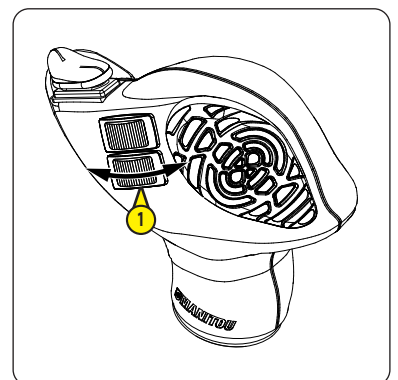
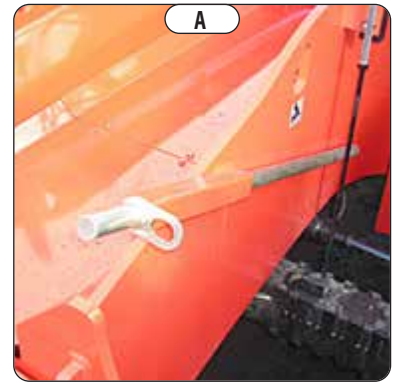

TECHNICAL SPECIFICATIONS OF ATTACHMENTS

FLOATING FORK SIDE-SHIFT CARRIAGE

REFERENCE	TFF 35 MT-1040 DL	TFF 35 MT-1300 DL
Rated capacity	3500 kg	3500 kg
Side-shift	2x100 mm	2x100 mm
Width	1040 mm	1300 mm
Weight	345 kg	375 kg

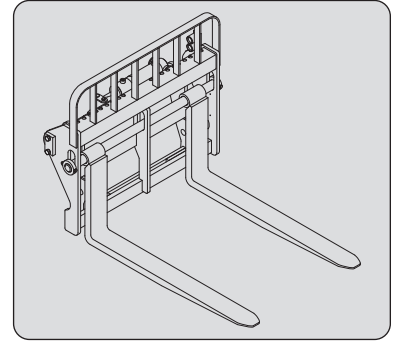

FLOATING FORK

REFERENCE	415801
Section	125x45x1200 mm
Weight	68 kg

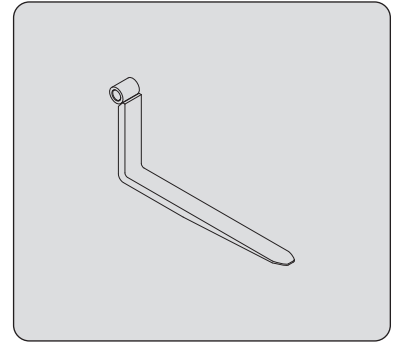

FORK POSITIONER

REFERENCE	CAF 1260/4500 P	CAF 1000/3LB	CAF 1000/3LB(b)
Rated capacity	52000273 4500 kg	52654990 3000 kg	52744200 3000 kg
Spacing	284/1010 mm	144/824 mm	164/804 mm
Width	1260 mm	1000 mm	1000 mm
Weight	350 kg	240 kg	254 kg

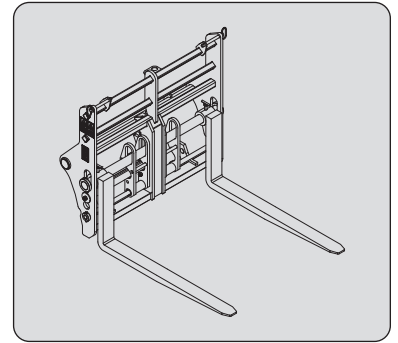

FLOATING FORK

REFERENCE	719611
Section	100x50x1200 mm
Weight	62 kg

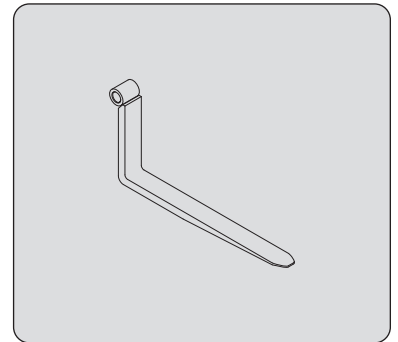

STANDARDIZED TILTING FORK CARRIAGE

REFERENCE	PFB 35 N MT-1260 S2	PFB 35 N MT-1470 S2	PFB 35 N MT-1580 S2
Rated capacity	653744 3500 kg	653745 3500 kg	653746 3500 kg
Width	1260 mm	1470 mm	1580 mm
Weight	95 kg	120 kg	125 kg

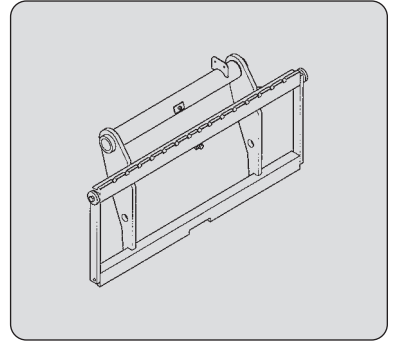

STANDARDIZED FORK

REFERENCE	415618
Section	125x45x1200 mm
Weight	72 kg

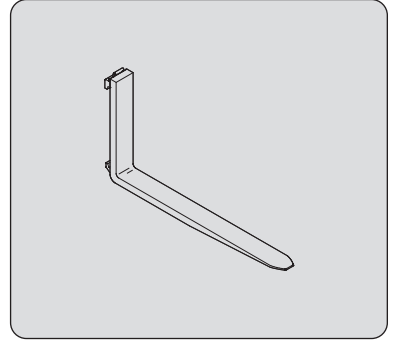

STANDARDIZED TILTING FORK CARRIAGE + LOAD BACK REST

REFERENCE	PFB 35N 1260 LB	PFB 35N 1470 LB
Rated capacity	52000200 3500 kg	52000201 3500 kg
Width	1260 mm	1470 mm
Weight	130 kg	158 kg

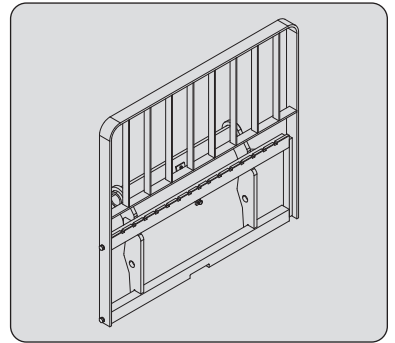

STANDARDIZED TILTING FORK CARRIAGE + STANDARDIZED SIDE-SHIFT CARRIAGE + LOAD BACK REST

REFERENCE	PFB 35 N 1260 DL/LB
Rated capacity	52000205 3500 kg
Side-shift	2x100 mm
Width	1260 mm
Weight	210 kg

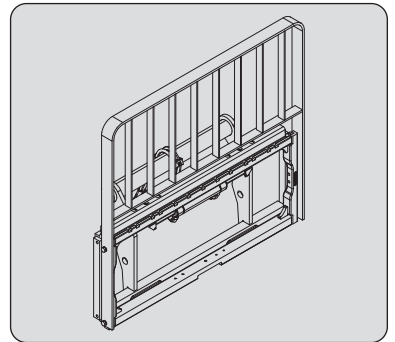

BUILDING BUCKET

	CBC 700 L1950 S2
REFERENCE	654472
Rated capacity	696 ℓ
Width	1950 mm
Weight	330 kg

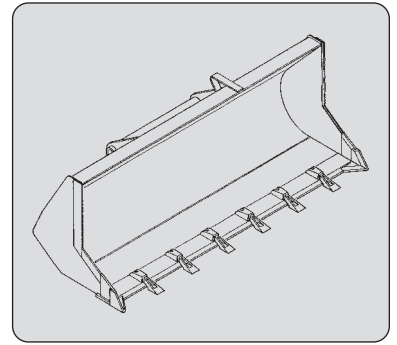

LOADING BUCKET

	CBR 780 L1950
REFERENCE	570613
Rated capacity	778 ℓ
Width	1950 mm
Weight	340 kg

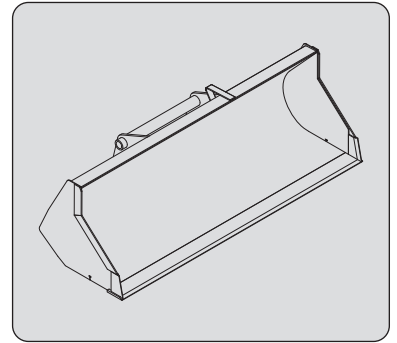

ALL-TASKS BUCKET

	BGP 2000/800 Essential
REFERENCE	52688160
Rated capacity	800 ℓ
Width	2000 mm
Weight	345 kg

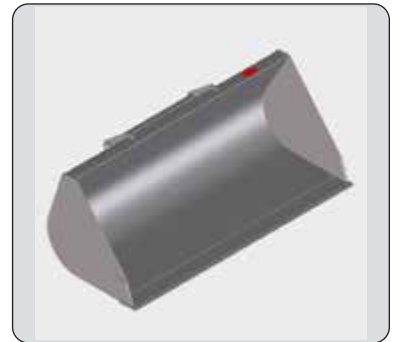

BUCKET 4-in-1

	CB4X1-700 L1950
REFERENCE	751402
Rated capacity	700 ℓ
Width	1950 mm
Weight	608 kg

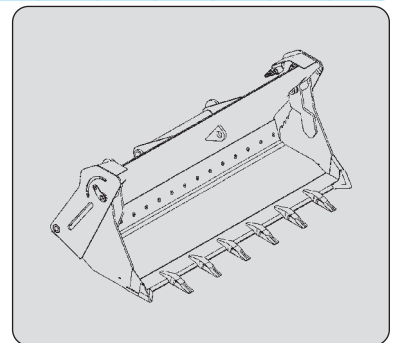

CONCRETE BUCKET (ADAPTABLE ON FORKS)

REFERENCE	BB 500 S4 52000637	BBH 500 S4 52000638
Rated capacity	500 l/1200 kg	500 l/1200 kg
Width	1110 mm	1110 mm
Weight	191 kg	200 kg

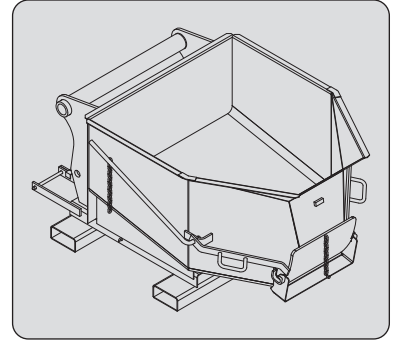

CONCRETE BUCKET WITH SPOUT (ADAPTABLE ON FORKS)

REFERENCE	BBG 500 S4 52000639	BBHG 500 S4 52000640
Rated capacity	500 l/1200 kg	500 l/1200 kg
Width	1110 mm	1110 mm
Weight	200 kg	210 kg

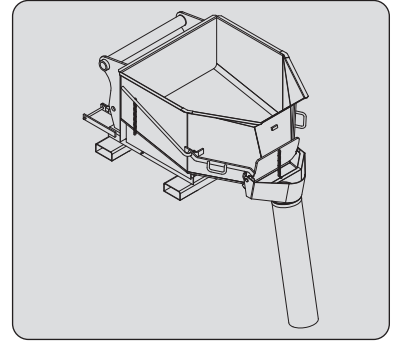

SPOUT BUCKET (ADAPTABLE ON FORKS)

REFERENCE	GL 600 S2 52000528	GL 600 H S2 52000529
Rated capacity	600 l/1440 kg	600 l/1440 kg
Weight	230 kg	245 kg



CRANE

REFERENCE	P 600 MT S3 653228
Rated capacity	600 kg
Weight	170 kg

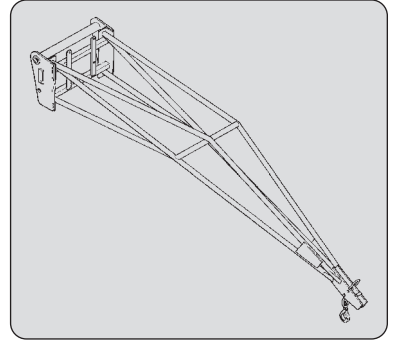

CRANE

REFERENCE	P 4000 MT S2 653226
Rated capacity	4000 kg/1200 kg
Weight	210 kg

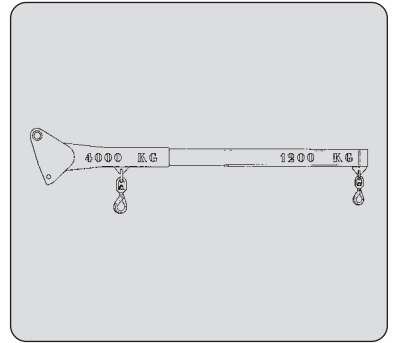

15°/15° MULTI-DIRECTIONAL CRANE JIB

REFERENCE	PO 600 / L2500 S2 784641	PO 1000 / L1500 S2 784642	PO 2000 / L1000 S2 784643
Rated capacity	600 kg	1000 kg	2000 kg
Weight	320 kg	275 kg	255 kg

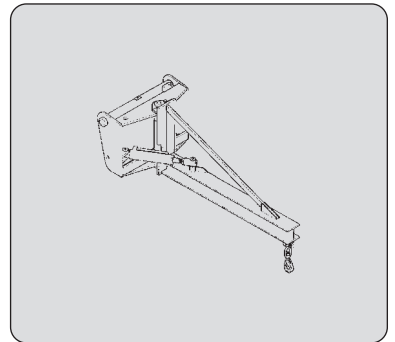

CRANE

REFERENCE	PC 50 708544
Rated capacity	5000 kg
Weight	120 kg

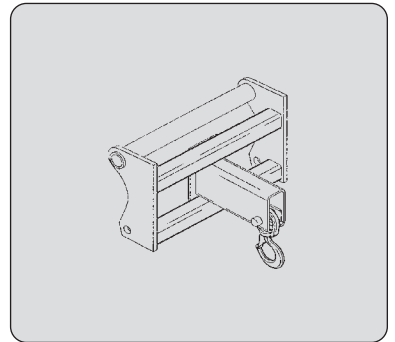

CRANE

REFERENCE	JE 6000/600 939995
Rated capacity	600 kg
Weight	265 kg

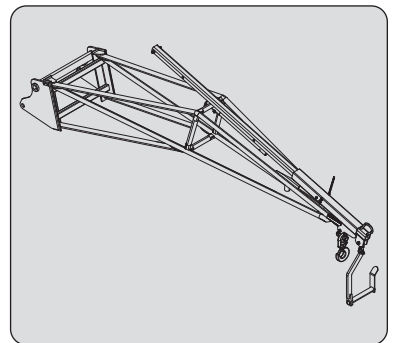

BOOM CRANE WITH BIG BAG

	HBB 1500/2400
REFERENCE	931627
Rated capacity	2400 kg
Weight	186 kg

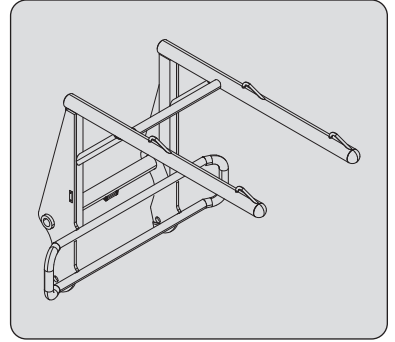

CLP 1000/800

	CLP 1000/800
REFERENCE	914770
Rated capacity	800 kg
Weight	119 kg



SWEeper WITH BRUSH

	SCC 2600
REFERENCE	52000515
Rated capacity	2600 mm
Width	2820 mm
Weight	450 kg

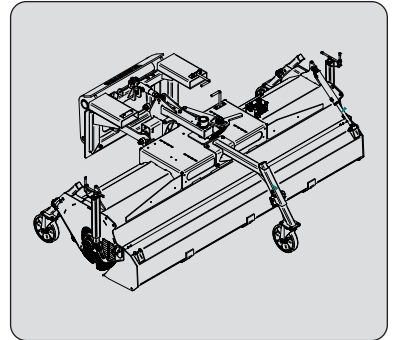

SWEeper WITH BRUSH

	SCC 2600+
REFERENCE	52000517
Rated capacity	2600 mm
Width	2820 mm
Weight	385 kg

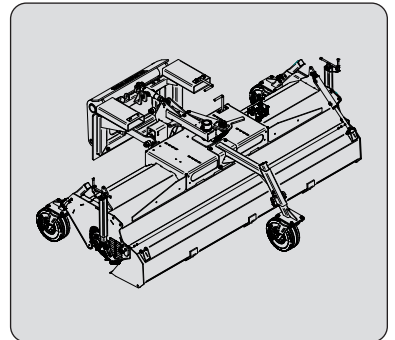

SWEeper WITH BRUSH

	SCC 2600 HWA+
REFERENCE	52000519
Rated capacity	2600 mm
Width	2820 mm
Weight	500 kg

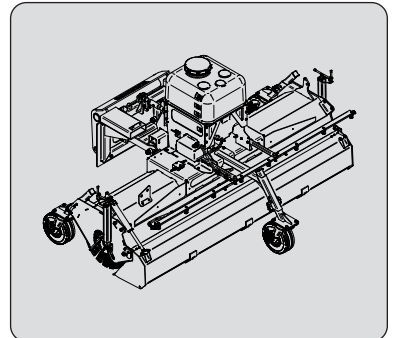

ATTACHMENT GUARDS

FORK GUARD

REFERENCE 227801

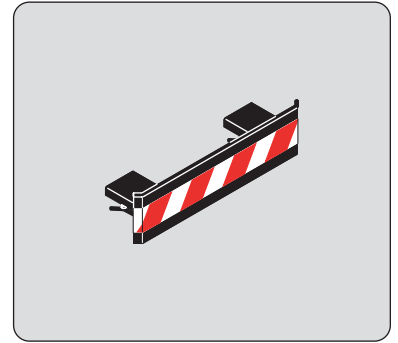

FORK BLOCK FOR FLOATING FORK CARRIAGE

REFERENCE 261210

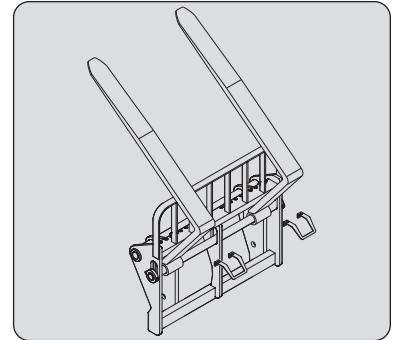

BUCKET PROTECTOR

Always ensure that the width of the protector you choose is less than or equal to the width of the bucket.

Width	REFERENCE 206734	206732	206730
	1375 mm	1500 mm	1650 mm
Width	REFERENCE 235854	206728	206726
	1850 mm	1950 mm	2000 mm
Width	REFERENCE 223771	223773	206724
	2050 mm	2100 mm	2150 mm
Width	REFERENCE 206099	206722	223775
	2250 mm	2450 mm	2500 mm

