

ZOOMLION

ROUGH TERRAIN ELECTRIC ARTICULATING BOOM LIFT

NEW ROUGH TERRAIN

ZA16JERT/ZA16JERT-Li Comply with CE/ANSI Standard

Model	ZA16JERT		ZA16JERT-Li	
	Imperial	Metric	Imperial	Metric
Size				
Work Height	58ft 5in	17.8m	58ft 5in	17.8m
Platform Height	51ft 10in	15.8m	51ft 10in	15.8m
Horizontal Outreach	31ft 11in	9.72m	31ft 11in	9.72m
Up and Over Height	26ft 3in	8m	26ft 3in	8m
A - Stowed Length	25ft 3in	7.7m	25ft 3in	7.7m
B - Stowed Width	7ft 6in	2.3m	7ft 6in	2.3m
C - Stowed Height	7ft 4in	2.23m	7ft 4in	2.23m
D - Platform Length	6ft	1.83m	5ft	1.52m
E - Platform Width	2ft 6in	0.76m	2ft 6in	0.76m
F - Wheelbase	7ft 9in	2.36m	7ft 9in	2.36m
G - Ground Clearance	1ft 2in	0.36m	1ft 2in	0.36m
Performance				
Platform Capacity	550 lb	250kg	550 lb	250kg
Drive Speed	3.79 mph	6.1km/h	3.4 mph	5.4 km/h
Gradeability	45%(24°)		45%(24°)	
Axles Oscillation	8in	0.20m	8in	0.20m
Turning Radius (Inside)	6ft 9in	2.06m	6ft 9in	2.06m
Turning Radius (Outside)	15ft 8in	4.78m	15ft 8in	4.78m
Turntable Swing	360° non-continuous		360° non-continuous	
Platform Rotation	±90°		±90°	
H-Tail Swing	8in	0.2m	0.6ft	0.2m
Max. Wind Speed	27.96mph	12.5m/s	27.96mph	12.5m/s
Power				
Battery	24×2V/320Ah		48V/315Ah Li-ion battery	
Charger	48V/35A		48V/60A	
Drive Motor	AC 32V		AC 32V	
Lift Motor	AC 32V		AC 32V	
Auxiliary Power	12V DC Electrical pump		12V DC Electrical pump	
Hydraulic Tank Capacity	7.9 (us gal)	30L	7.9 (us gal)	30L
Tire				
Type	33×12 Foam-filled tire		33×12 Foam-filled tire	
Weight				
Gross	16093 lb	7300 kg	16093lb	7300kg

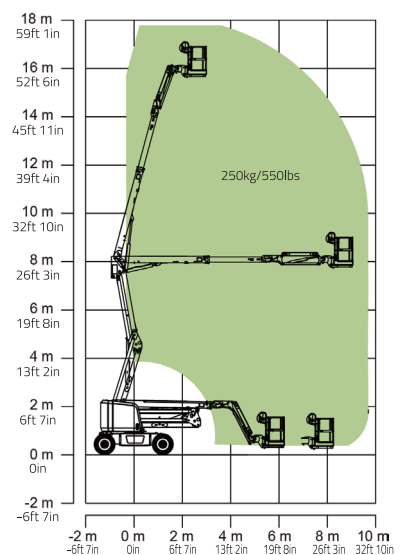
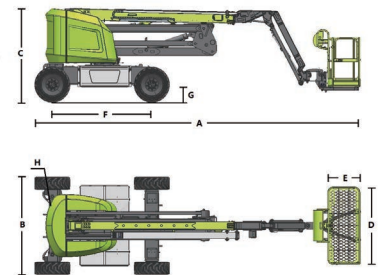

Range of Motion ZA16JERT/ZA16JERT-Li