

# **PARTS MANUAL**

**HL-140-160-190 E12**  
**N-120-140-165EL12**

*May 2015*

**HOLLAND LIFT**

**copyright © 2015, HOLLAND LIFT INTERNATIONAL B.V., Hoorn, Nederland**

Alle rights reserved. No parts of this publication may be reproduced and/or made public by print, fotocopy, microfilm or otherwise, without the prior written permission of **HOLLAND LIFT INTERNATIONAL B.V.**.

**HOLLAND LIFT INTERNATIONAL B.V.** remains the right to change parts at any time, without preceding or previous notice to the customer. The contents of this publication can likewise be changed without previous warning.

Designer and creator : **L. Sussenbach-Kortoeef**

# TABLE OF CONTENTS

<b>SECTION PLATFORM</b> .....	5
Extension Deck 1.....	6
Extension Deck 2.....	8
Extension Deck 3.....	10
Extension Deck 4.....	12
Main Deck 1 .....	14
Main Deck 2 .....	16
Main Deck 3 .....	18
Main Deck 4.....	20
<b>SECTION SCISSOR</b> .....	23
Scissor Overview HL-140 - N-120.....	24
Scissor Overview HL-160 - N-140.....	25
Scissor Overview HL-190 - N-165.....	26
1st Scissor arms .....	28
2nd Scissor arms .....	30
3rd Scissor arms.....	32
4th Scissor arms.....	34
5th Scissor arms.....	36
6th Scissor arms.....	38
Joint 1-21-22.....	40
Joint 2 .....	42
Joint 15 .....	44
Joint 4 .....	46
Joint 3 .....	48
Joint 16 .....	50
Joint 5 .....	52
Joint 6 .....	54
Joint 17 .....	56
Joint 8 .....	58
Joint 8-12 .....	60
Joint 7 .....	62
Joint 7-11 .....	64
Joint 18 .....	66
Joint 9 .....	68

Joint 10 .....	70
Joint 9-12 .....	72
Joint 10-11 .....	74
Joint 19 .....	76
Joint 12 .....	78
Joint 11 .....	80
Joint 20-A .....	82
Joint 20-B .....	84
Joint 20-C .....	86
Joint 13 .....	88
Joint 14 .....	90
Cable guide HL-140 - N-120 .....	92
Cable guide HL-160 - N-140 .....	94
Cable guide HL-190 - N-165 .....	96
<b>SECTION FRAME</b> .....	<b>99</b>
Frame .....	100
Steering axle .....	102
Fixed Axle .....	104
Pothole Protection 1-2 .....	106
Pothole Protection 2-2 .....	108
Protection Fence 1-4 .....	110
Protection Fence 2-4 .....	112
Protection Fence 3-4 .....	114
Ladder HL-140 - N-120 .....	118
Ladder HL-160 - N-140 .....	120
Ladder HL-190 - N-165 .....	122
<b>SECTION CONTROL</b> .....	<b>125</b>
Control Box .....	126

# SECTION PLATFORM

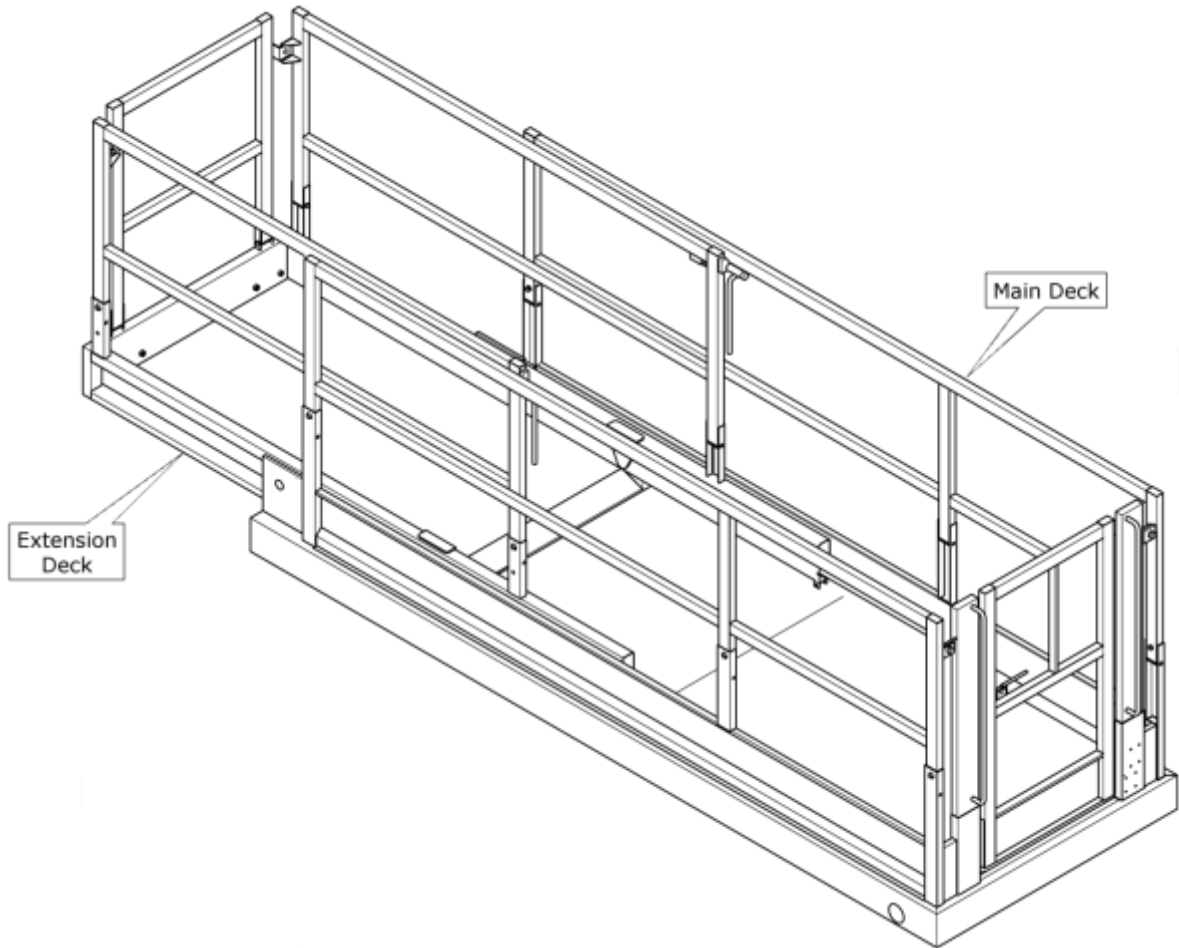

## Extension Deck 1

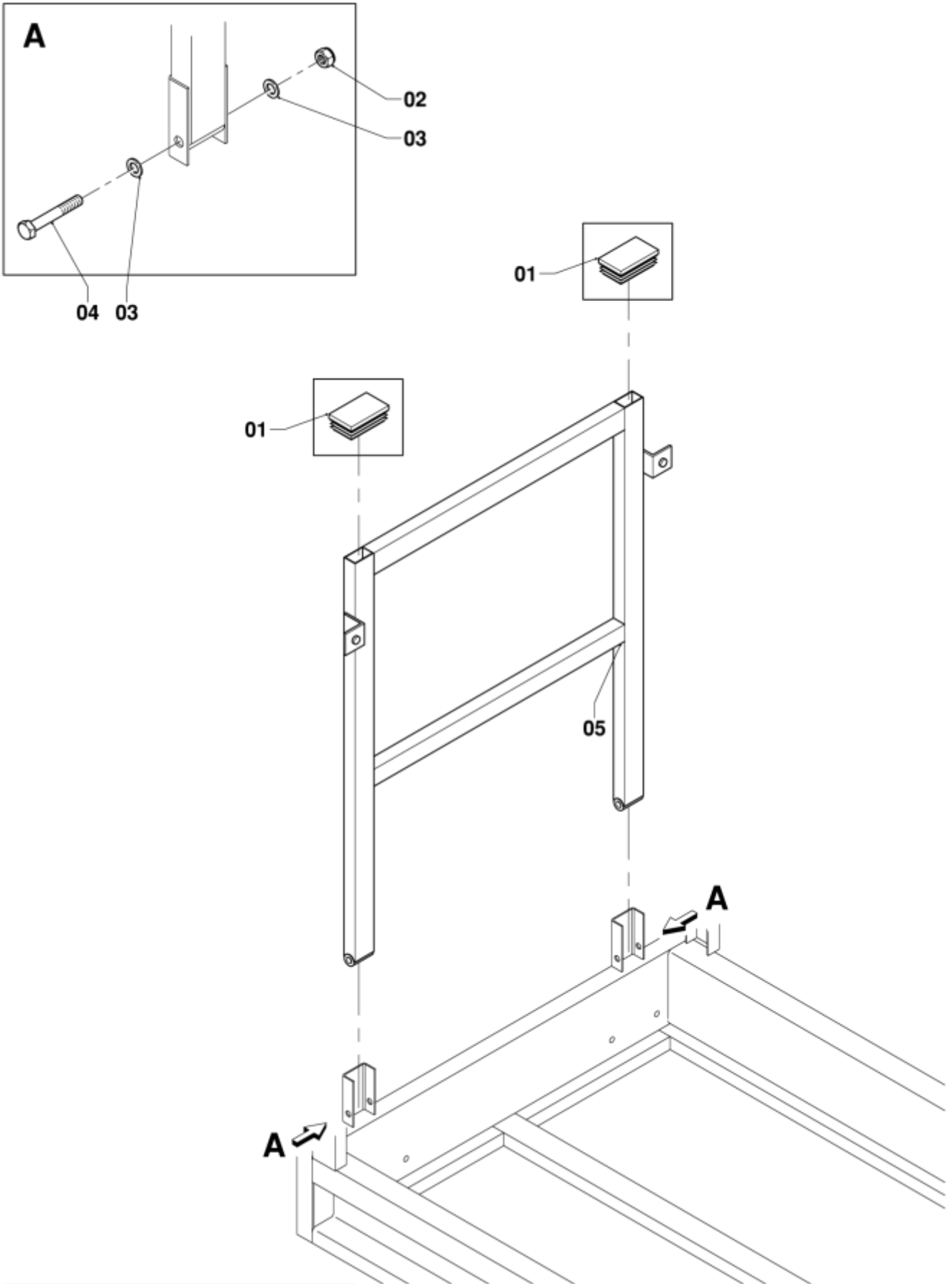

<b>Item</b>	<b>Qty</b>	<b>Part number</b>	<b>Description</b>
1	2	STOP050	Plug
2	2	12300.100.001	Nut, DIN 985
3	4	38130.100.001	Washer, DIN 125-A
4	2	01200.100.080	Bolt, DIN 931
5	1	V12-02-62-1	Railing

### Extension Deck 2

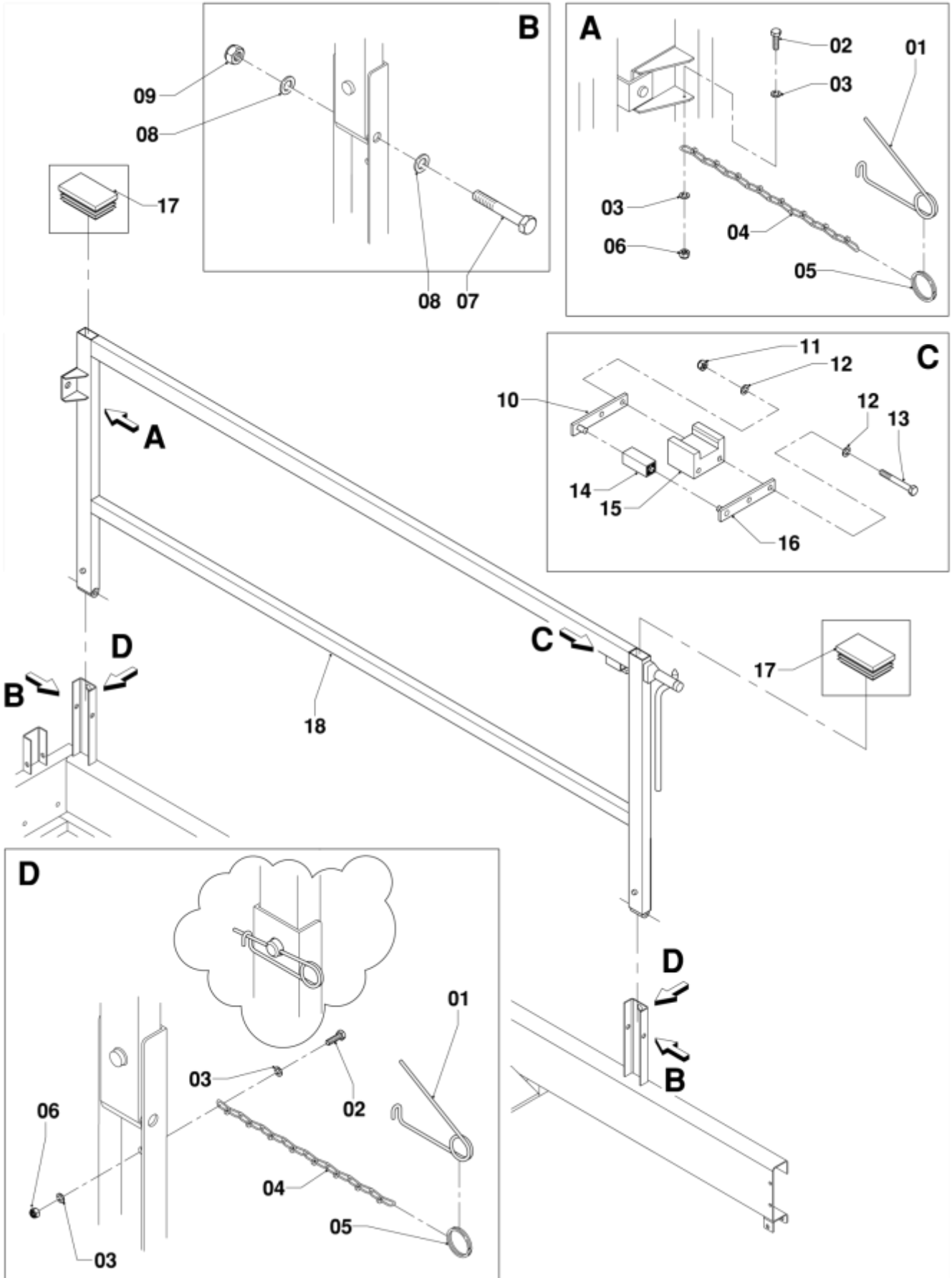



Item	Qty	Part number	Description
1	3	VEER001	Locking pin
2	4	01210.050.020	Bolt, DIN 933
3	7	38130.050.001	Washer, DIN 125-A
4	4	KETTING010	Chain
5	4	RING01	Key ring
6	3	12300.050.001	Nut, DIN 985
7	2	1200.100.080	Bolt, DIN 931
8	4	38130.100.001	Washer, DIN 125-A
9	2	12300.100.001	Nut, DIN 985
10	1	N-01-50-1	Lever, left
11	2	12300.060.001	Nut, DIN 985
12	4	38130.060.001	Washer, DIN 125-A
13	2	1200.060.080	Bolt, DIN 931
14	1	SPANELEM001	Torsion spring
15	1	N-01-50-2	Sliding block
16	1	N-01-50-3	Lever, right
17	2	STOP050	Plug
18	1	V12-02-62-2	Railing

### Extension Deck 3

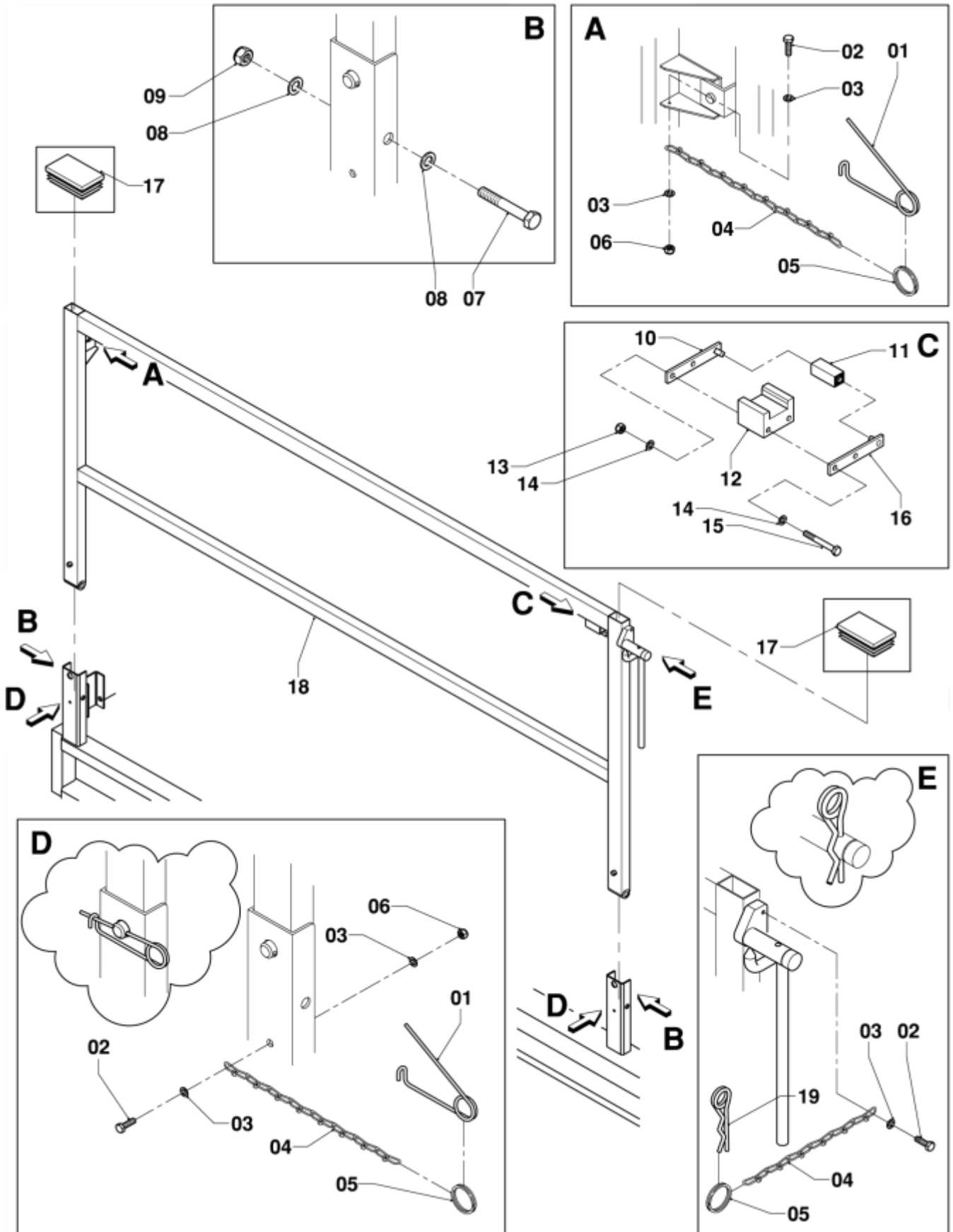

Item	Qty	Part number	Description
1	3	VEER001	Locking pin
2	3	01210.050.020	Bolt, DIN 933
3	6	38130.050.001	Washer, DIN 125-A
4	3	KETTING010	Chain
5	3	RING01	Key ring
6	3	12300.050.001	Nut, DIN 985
7	2	01200.100.080	Bolt, DIN 931
8	4	38130.100.001	Washer, DIN 125-A
9	2	12300.100.001	Nut, DIN 985
10	1	N-01-50-1	Lever, right (STRIP010)
11	1	SPANELEM001	Tensioning spring
12	1	N-01-50-2	Sliding block (GLIJBLOK015)
13	2	12300.060.001	Nut, DIN 985
14	4	38130.060.001	Washer, DIN 125-A
15	2	01200.060.080	Bolt, DIN 931
16	1	N-01-50-1	Lever, left (STRIP010)
17	2	STOP050	Plug
18	1	V12-02-62-3	Railing

### Extension Deck 4

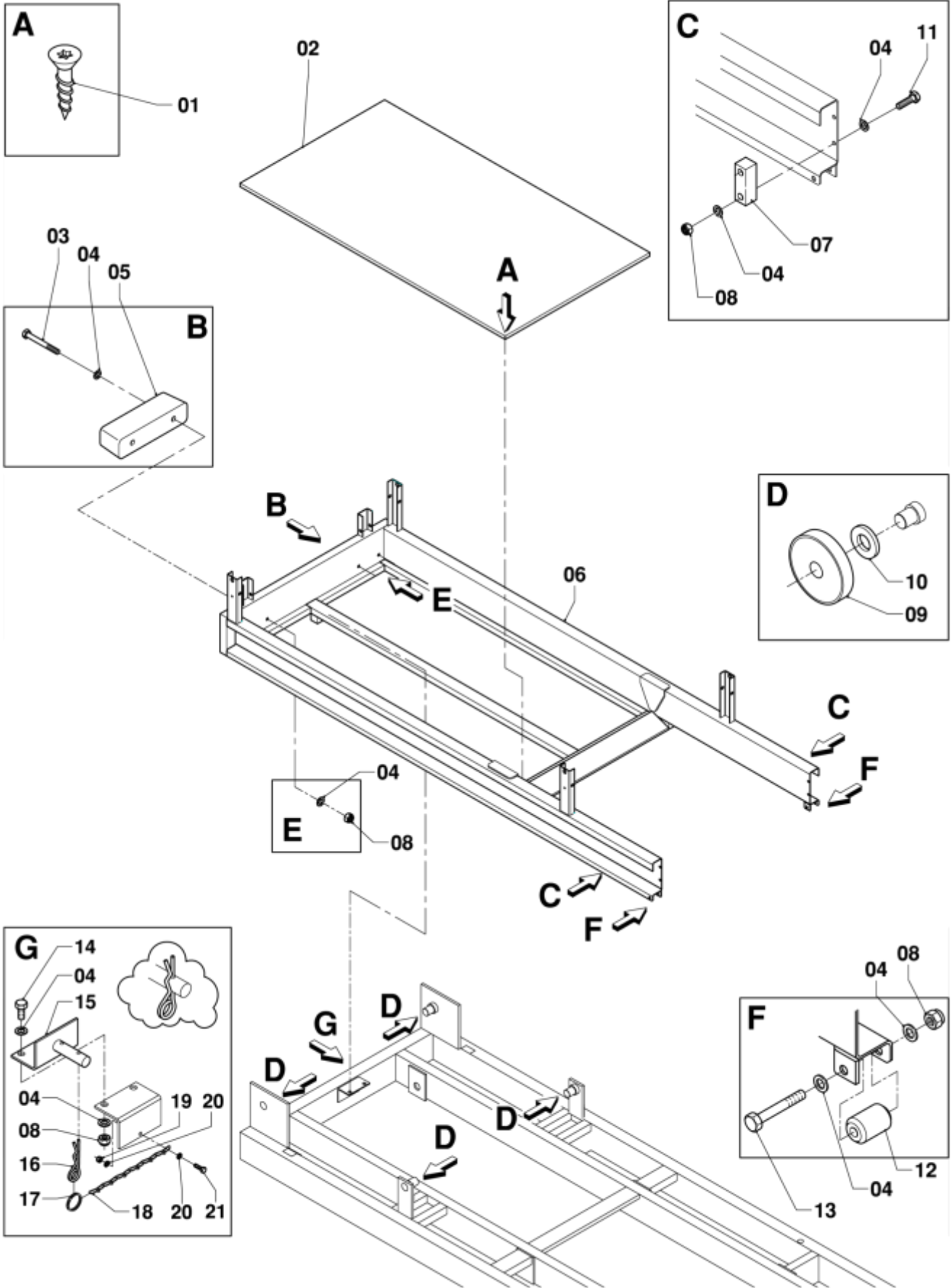

Item	Qty	Part number	Description
1	-	SPEDEC 50	Screw 6,3x38 (¼-1½) DIN 7982 C-T
2	1	V12-02-52-1	Floor plate (HOUT362)
3	4	01200.100.085	Bolt, DIN 931
4	24	38130.100.001	Washer, DIN 125-A
5	2	STOOTR20	Buffer
6	1	V12-02-51-1	Extension frame
7	2	V12-02-51-2	Stop block
8	12	12300.100.001	Nut, DIN 985
9	4	V-01-50	Plastic wheel (LOOPROL25)
10	4	38.130.360.001	Washer, DIN 125-A
11	4	01200.100.045	Bolt, DIN 931
12	2	V-01-53	Roller (ERTALON61)
13	2	01200.100.075	Bolt, DIN 931
14	2	01210.100.030	Bolt, DIN 933
15	1	X-01-46	Bracket (BORG.BORDES)
16	1	HAARSP030	Locking pin
17	1	RING01	Key ring
18	1	KETTING010	Chain
19	1	12300.050.001	Nut, DIN 985
20	2	38130.050.001	Washer, DIN 125-A
21	1	01210.050.020	Bolt, DIN 933

# Main Deck 1

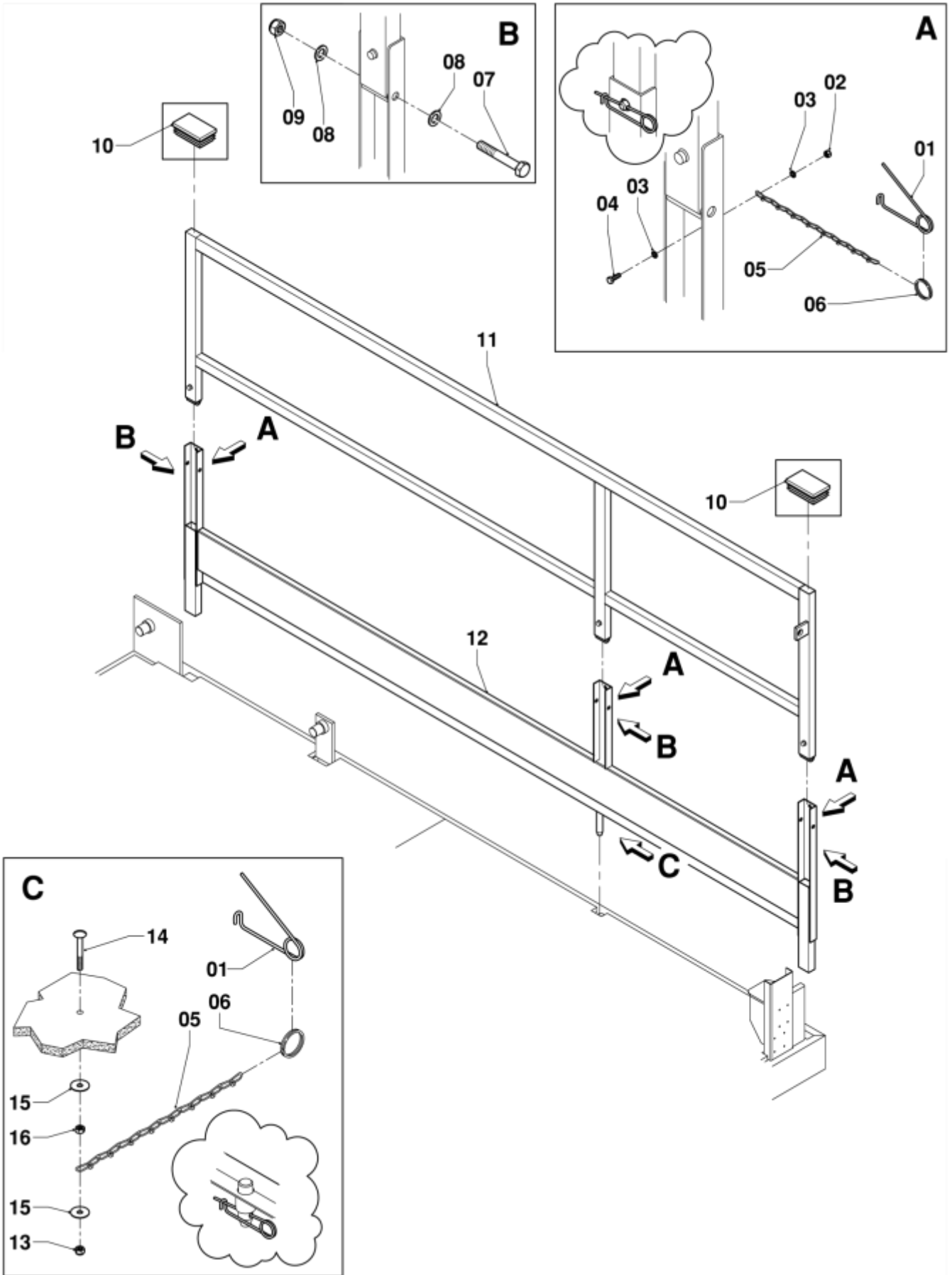

Item	Qty	Part number	Description
1	4	VEER001	Locking pin
2	3	12300.050.001	Nut, DIN 985
3	6	38130.050.001	Washer, DIN 125-A
4	3	01210.050.020	Bolt, DIN 933
5	4	KETTING010	Chain
6	4	RING01	Key ring
7	3	01200.120.080	Bolt, DIN 931
8	6	38130.120.001	Washer, DIN 125-A
9	3	12300.120.001	Nut, DIN 985
10	2	STOP050	Plug
11	1	V12-02-61-1	Railing upper part, left
12	1	V12-02-61-2	Railing lower part, left
13	1	38130.060.001	Washer, DIN 125-A
14	1	08250.050.025	Bolt, DIN 603/555
15	2	38400.050.025	Washer
16	1	01300.050.001	Nut, DIN 934

## Main Deck 2

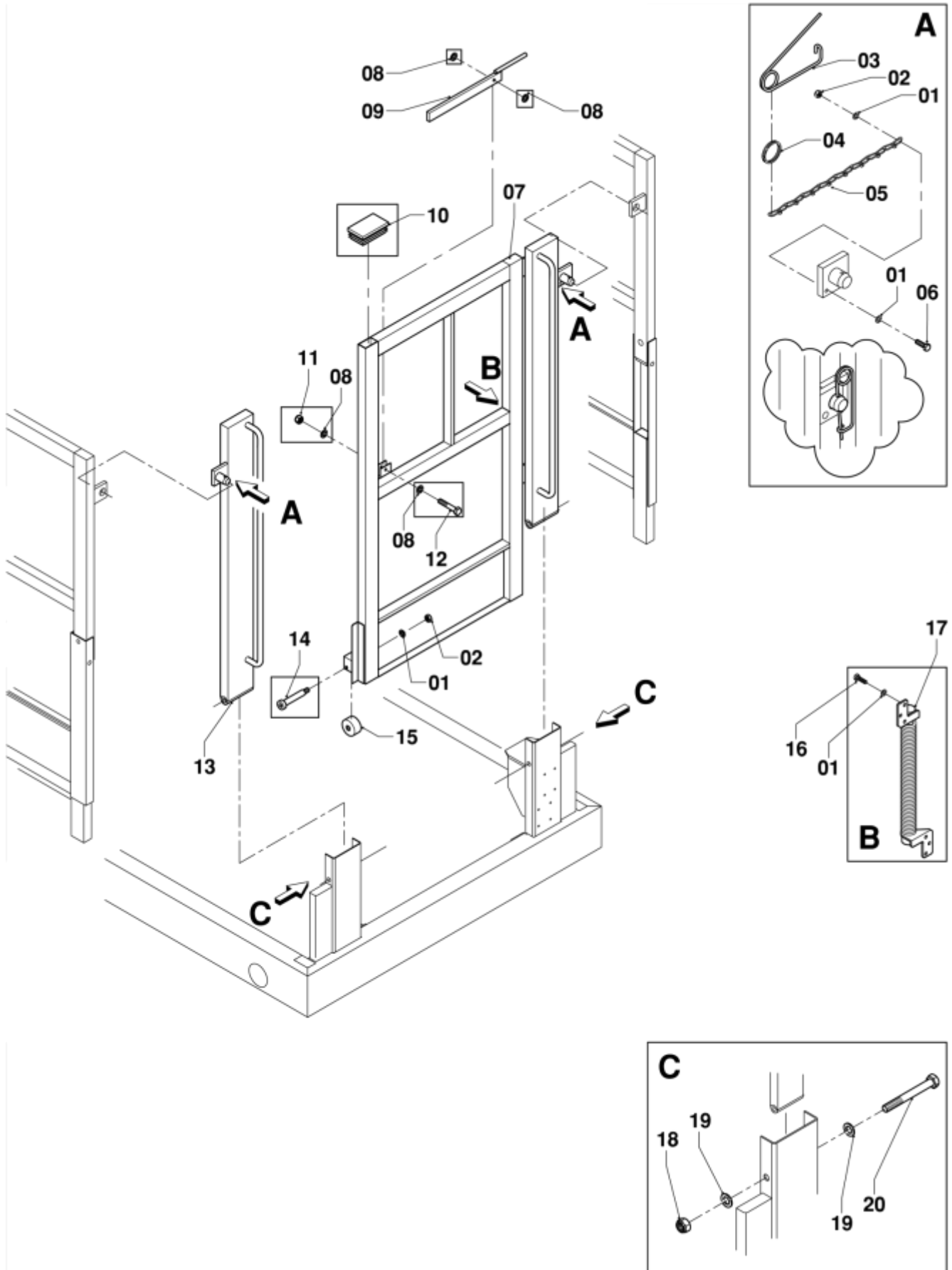



Item	Qty	Part number	Description
1	11	38130.050.001	Washer, DIN 125-A
2	3	12300.050.001	Nut, DIN 985
3	2	VEER001	Locking pin
4	2	RING01	Key ring
5	2	KETTING010	Chain
6	2	01210.050.025	Bolt, DIN 933
7	1	V12-02-61-3	Railing
8	4	38130.060.001	Washer, DIN 125-A
9	1	N-01-13	Latch
10	2	STOP050	Plug
11	1	12300.060.001	Nut, DIN 985
12	1	01210.060.030	Bolt, DIN 933
13	1	V12-02-61-4	Railing
14	1	PASSCHR.M5	M5 ISO 7379 f9 - 12.9
15	1	ERTALON 50	Roller
16	6	01210.050.010	Bolt, DIN 933
17	1	DEURSL.GUNCO	Door spring
18	2	12300.120.001	Nut, DIN 985
19	4	38130.120.001	Washer, DIN 125-A
20	2	07160.120.080	Bolt, DIN 912

### Main Deck 3

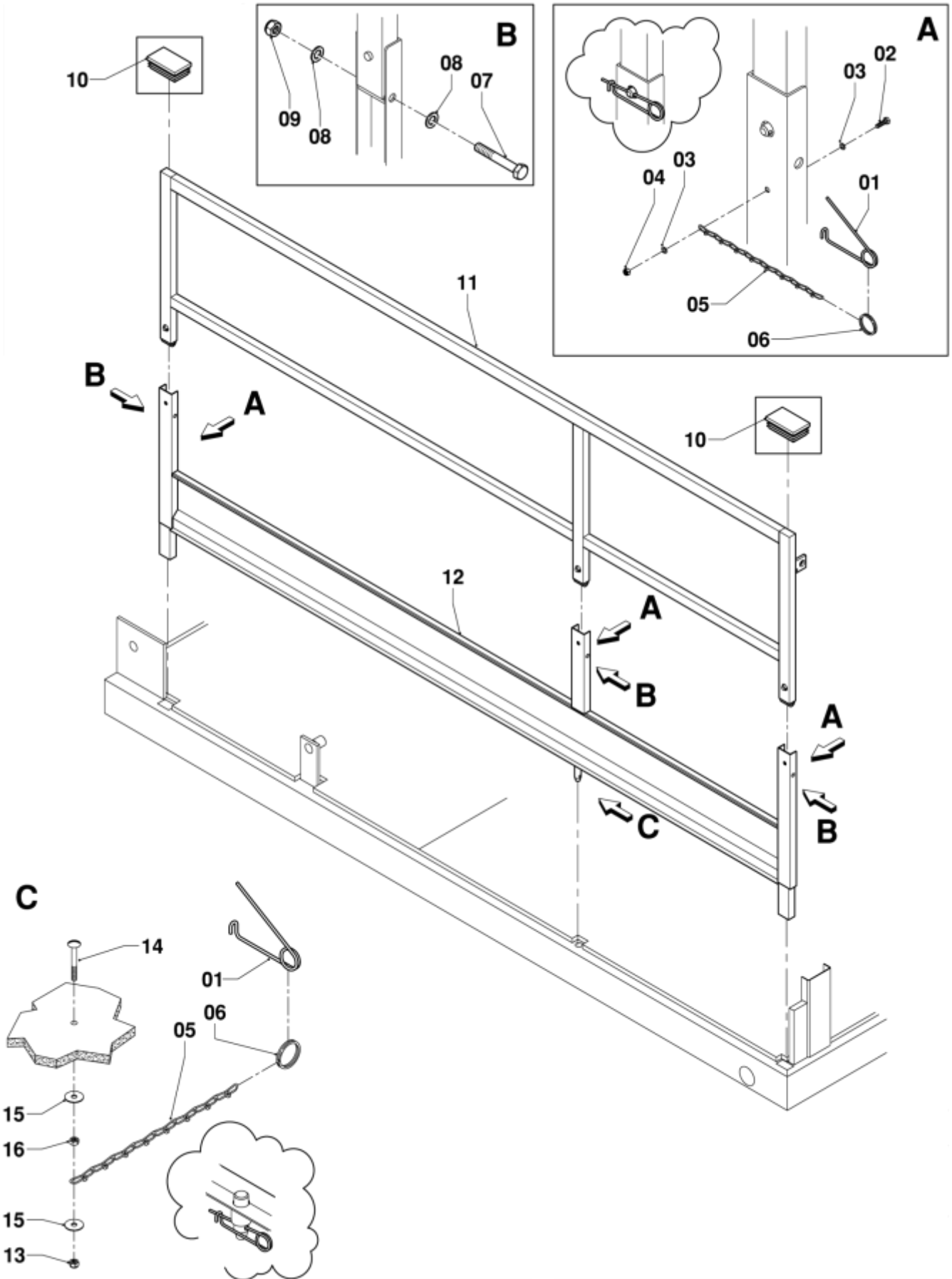

Item	Qty	Part number	Description
1	4	VEER001	Locking pin
2	3	12300.050.001	Nut, DIN 985
3	6	38130.050.001	Washer, DIN 125-A
4	3	01210.050.020	Bolt, DIN 933
5	4	KETTING010	Chain
6	4	RING01	Key ring
7	3	01200.120.080	Bolt, DIN 931
8	6	38130.120.001	Washer, DIN 125-A
9	3	12300.120.001	Nut, DIN 985
10	2	STOP050	Plug
11	1	V12-02-61-5	Railing upper part, right
12	1	V12-02-61-6	Railing lower part, right
13	1	38130.060.001	Washer, DIN 125-A
14	1	08250.050.025	Bolt, DIN 603/555
15	2	38400.050.025	Washer
16	1	01300.050.001	Nut, DIN 934

# Main Deck 4

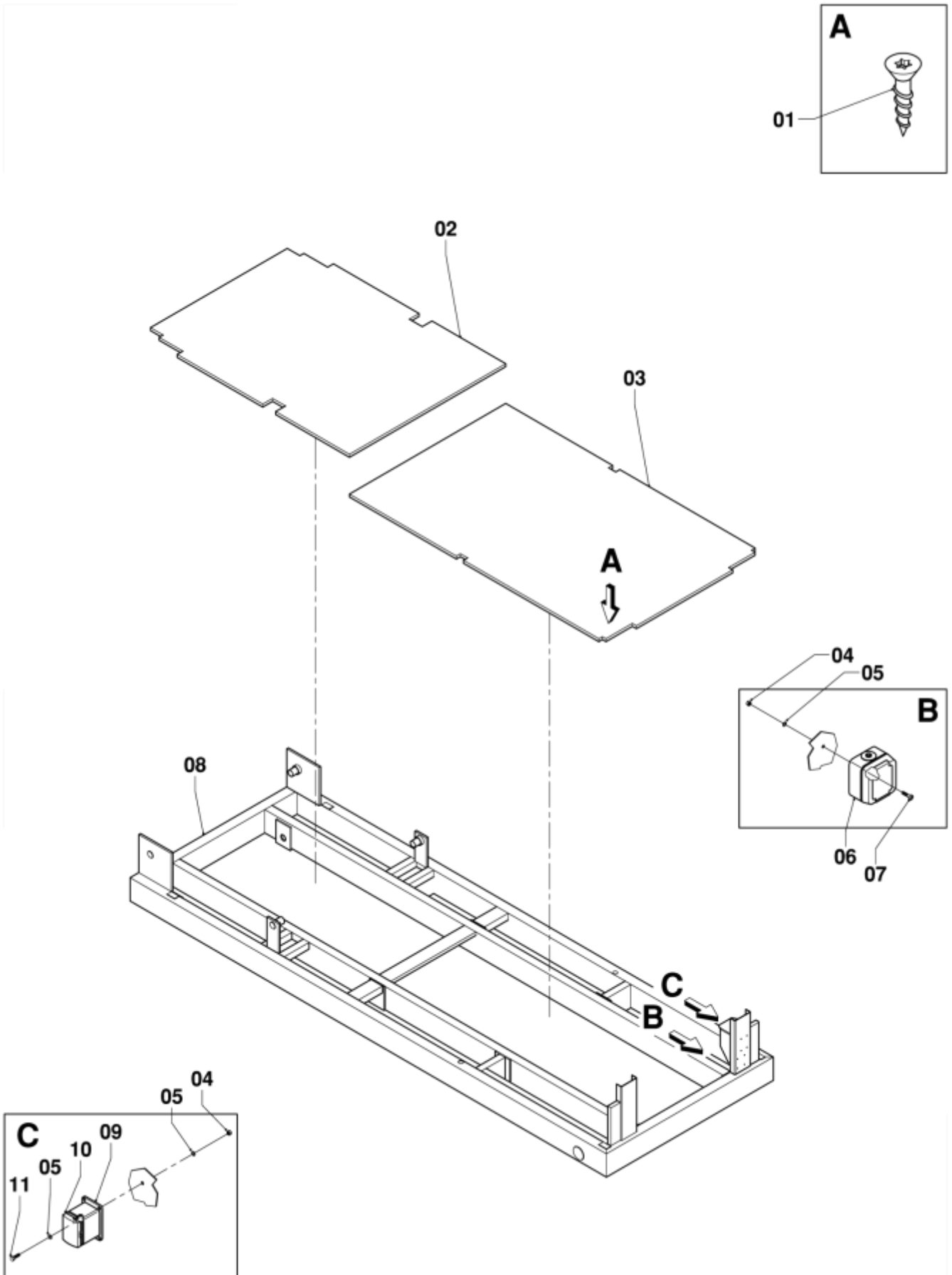

Item	Qty	Part number	Description
1	-	SPEDEC 50	Screw 6,3x38 (¼-1½) DIN 7982 C-T
2	1	V12-02-52-2	Floor plate (HOUT360)
3	1	V12-02-52-3	Floor plate (HOUT361)
4	8	12300.050.001	Nut, DIN 985
5	12	38130.050.001	Washer, DIN 125-A
6	1	CONT.DS220	Socket outlet (230 V)
7	4	24520.050.020	Screw, DIN 84
8	1	V12-02-48	Solid platform frame
9	1	STEKH 6P	Housing
10	1	STEK B 6B	Female insert
11	4	01210.050.020	Bolt, DIN 933



# **SECTION SCISSOR**

### Scissor Overview HL-140 - N-120

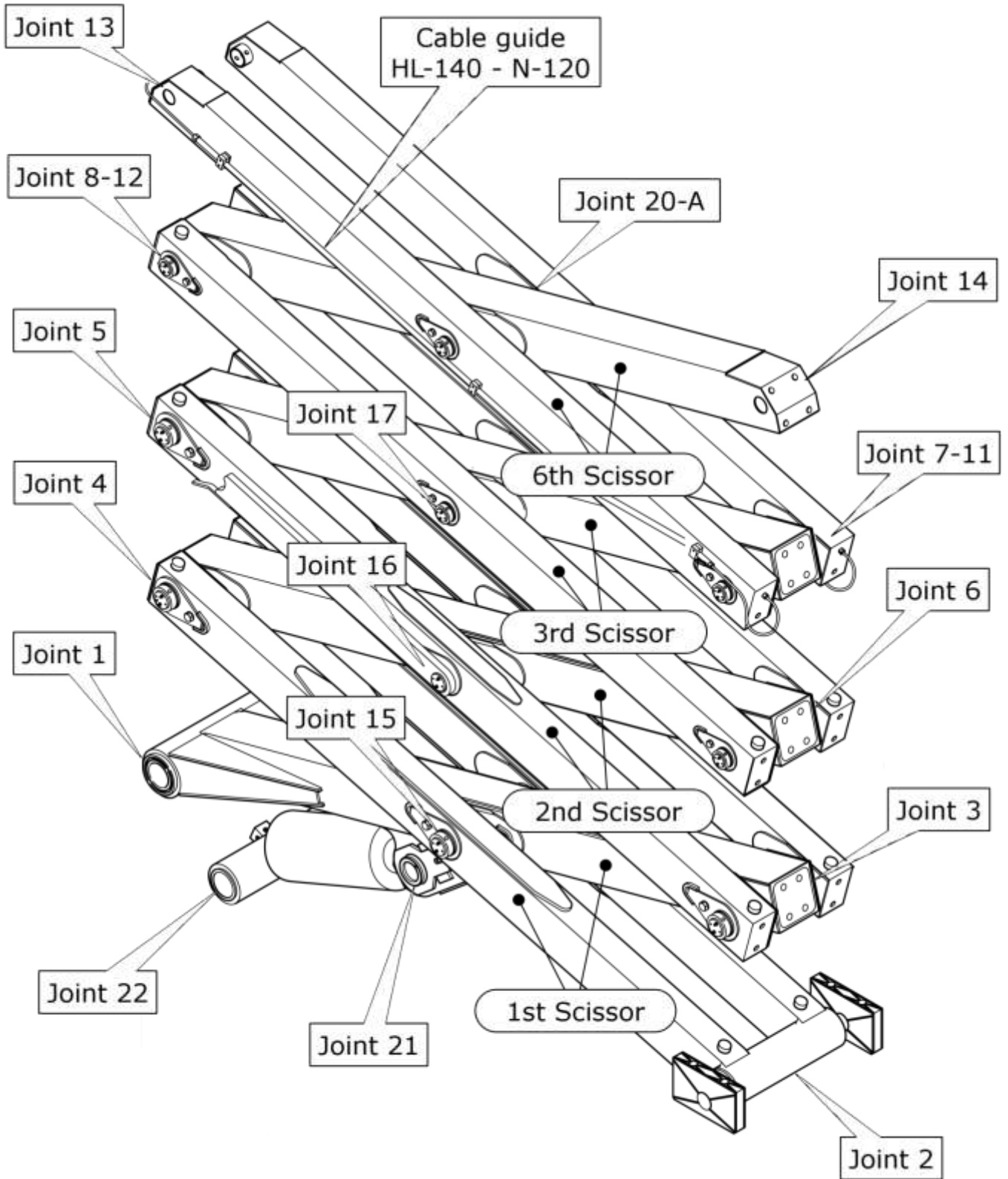



### Scissor Overview HL-160 - N-140

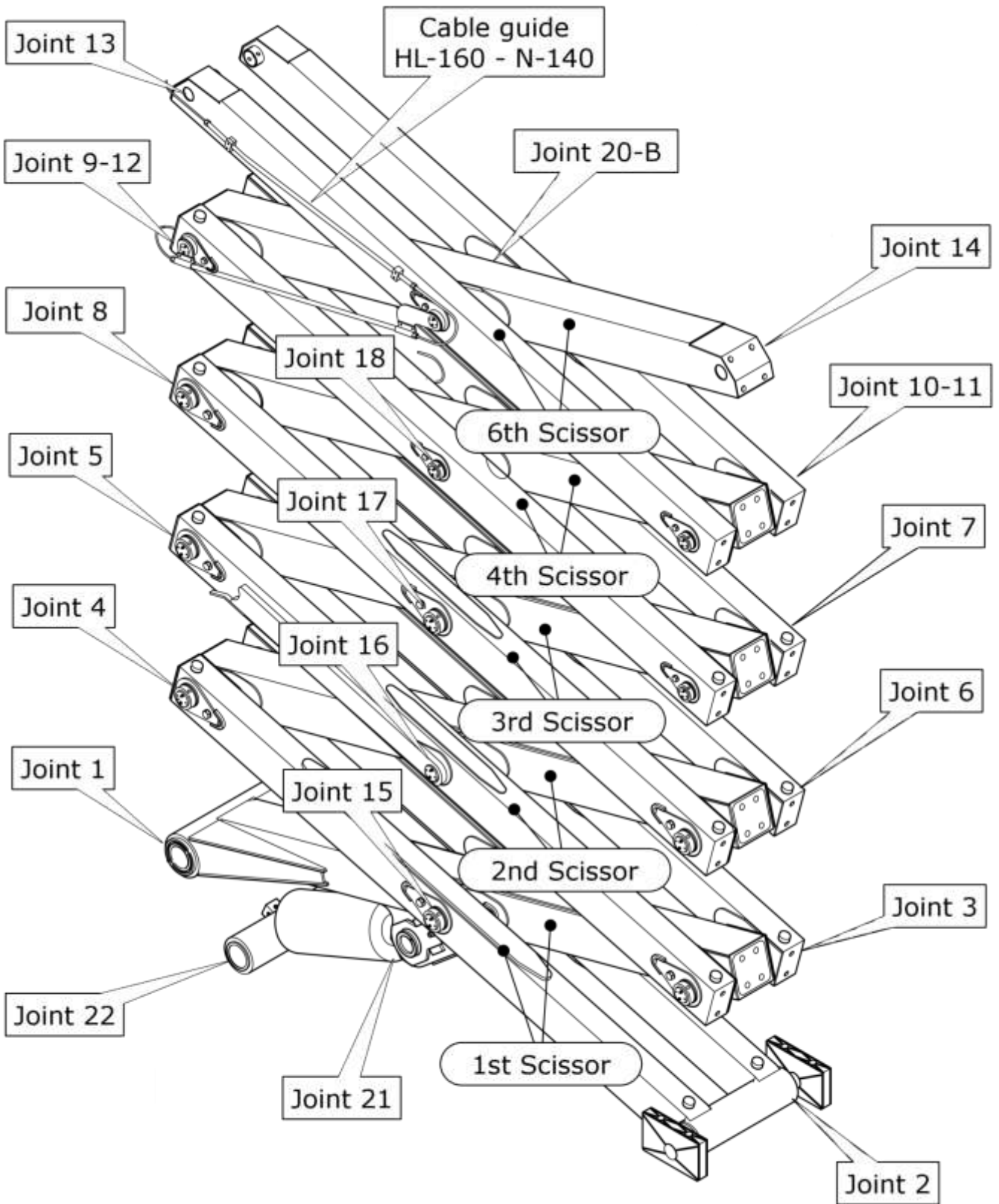

### Scissor Overview HL-190 - N-165

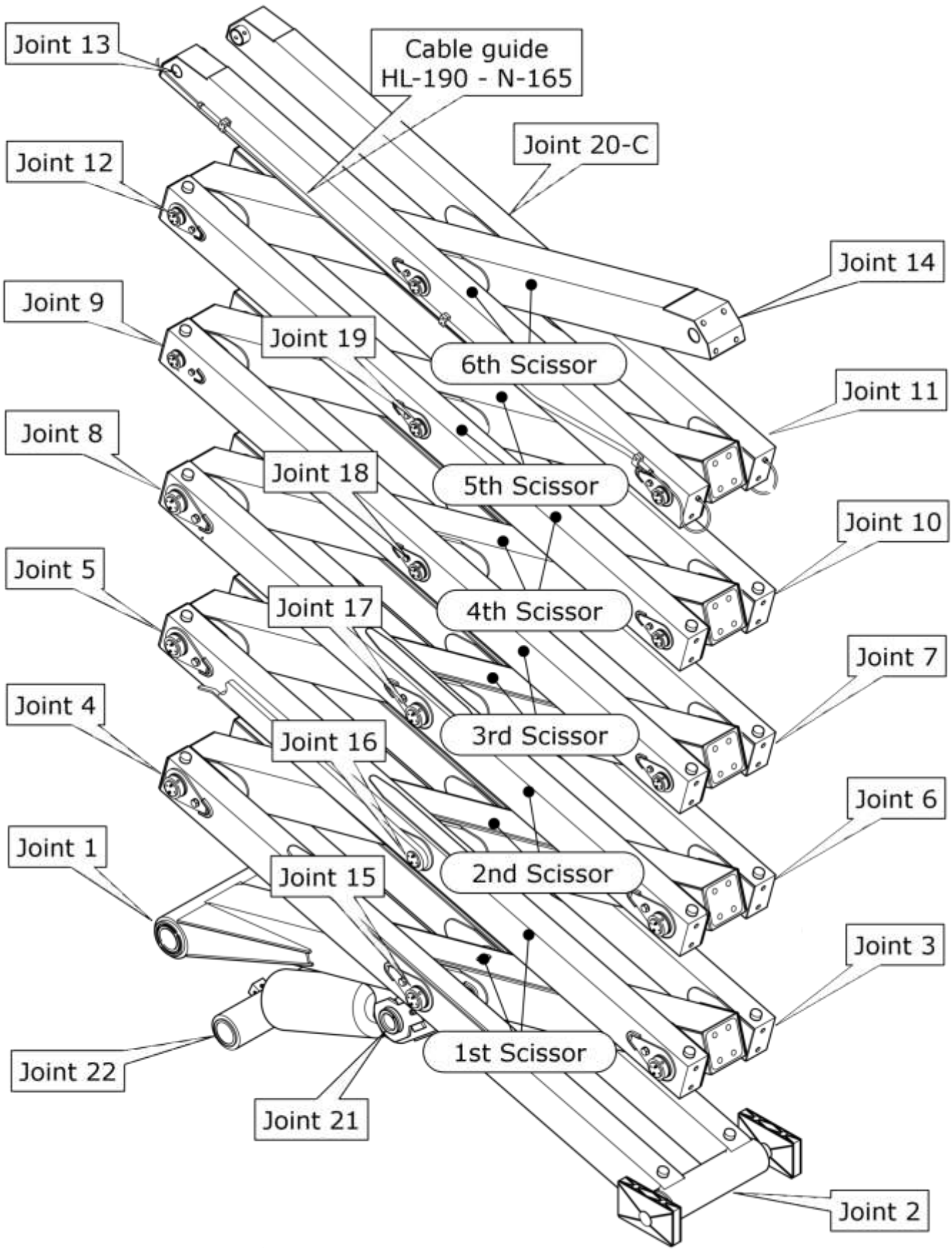



# 1st Scissor arms

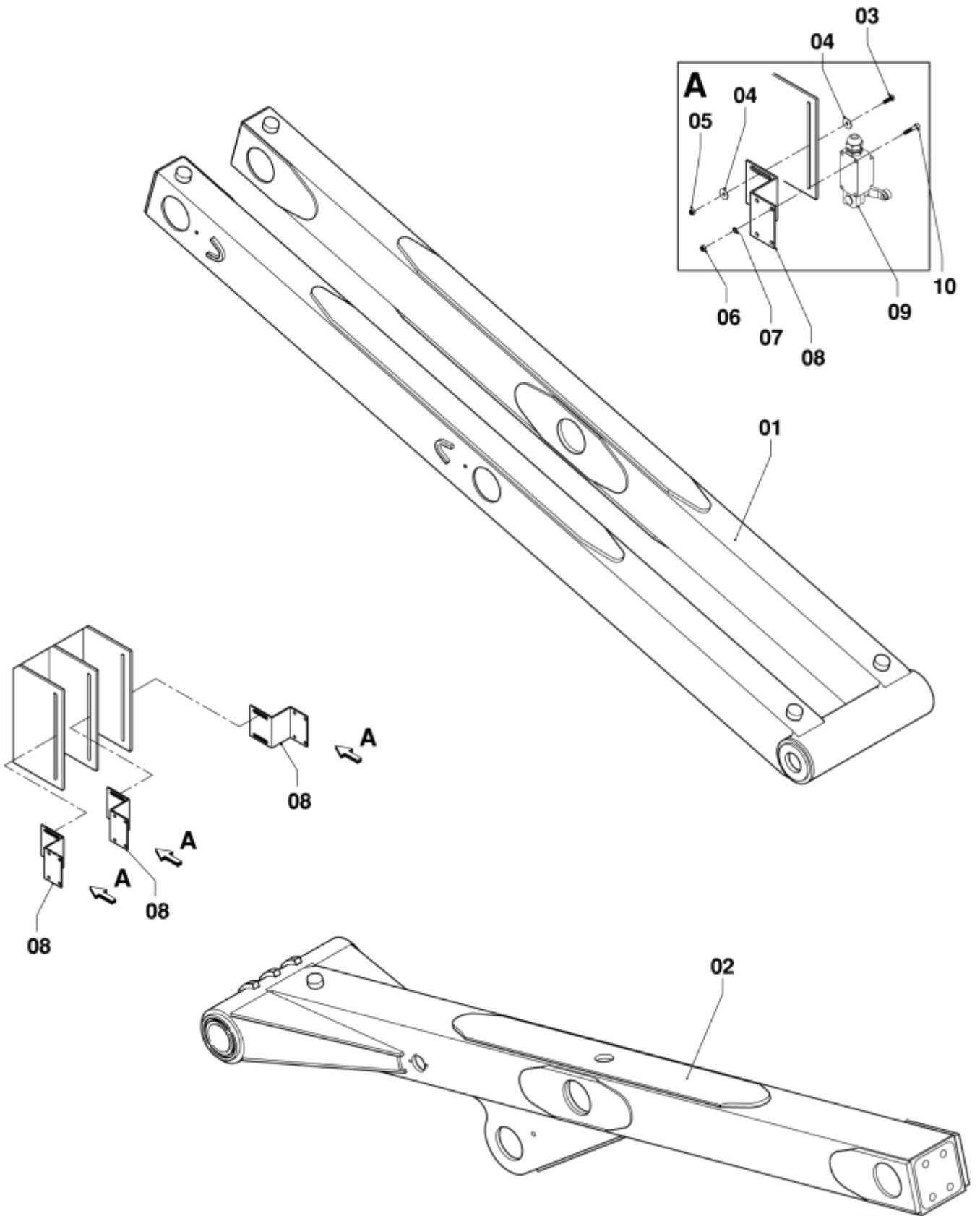

Item	Qty	Part number	Description
1	1	V-01-24	1 <sup>st</sup> Outer scissor arm
2	1	V-01-23	1 <sup>st</sup> Inner scissor arm
3	6	01210.060.020	Bolt, DIN 933
4	12	38400.060.020	Washer
5	6	12300.060.001	Nut, DIN 985
6	12	12300.050.001	Nut, DIN 985
7	12	38130.050.001	Washer, DIN 125-A
8	3	V-01-72	Switch plate
9	3	SCHAK1	Switch
10	12	07160.050.050	Bolt, DIN 912

## 2nd Scissor arms

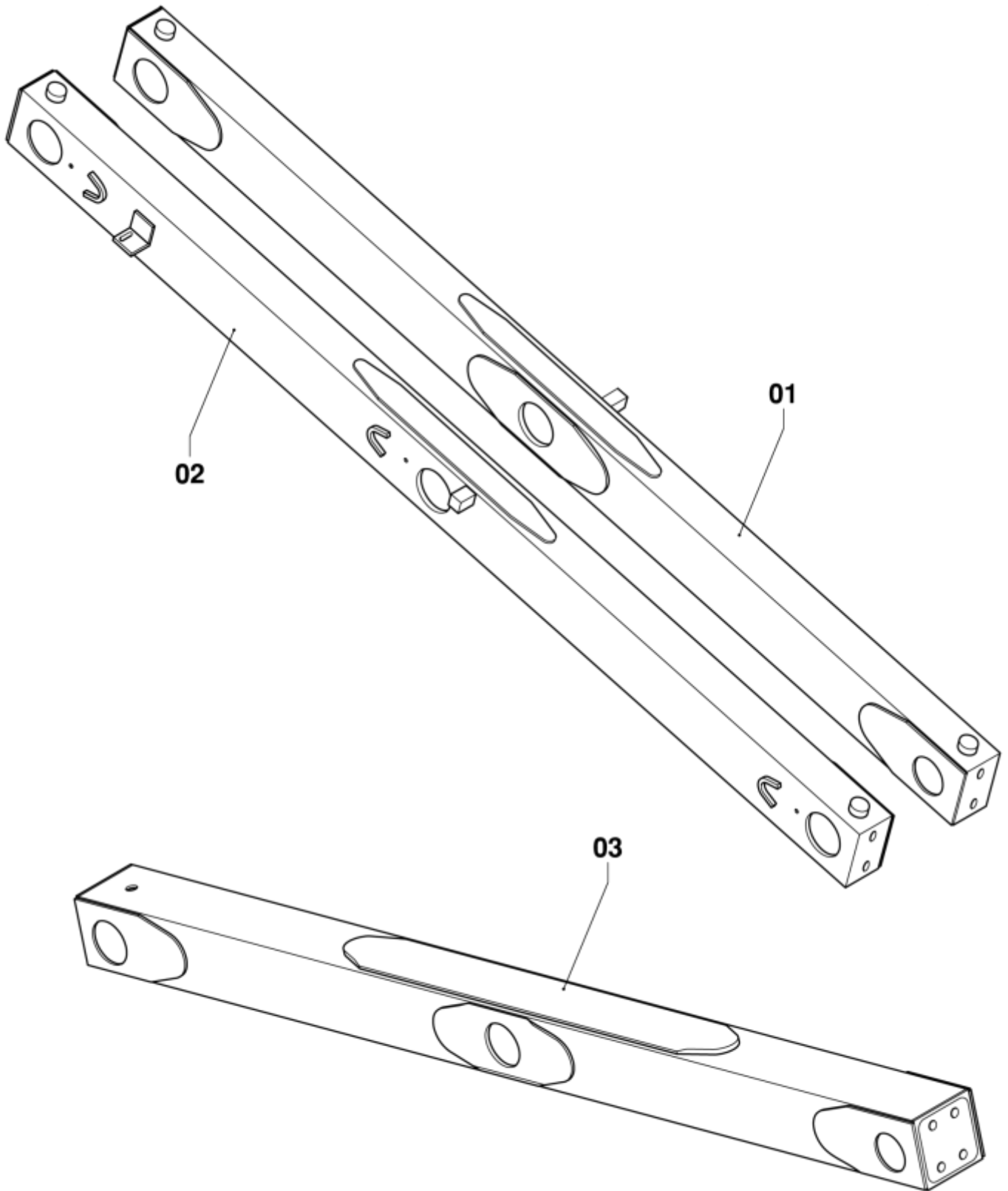

<b>Item</b>	<b>Qty</b>	<b>Part number</b>	<b>Description</b>
1	1	V-02-26-1	2 <sup>nd</sup> Outer scissor arm, Left
2	1	V-02-26-2	2 <sup>nd</sup> Outer scissor arm, Right
3	1	V-01-25	2 <sup>nd</sup> Inner scissor arm

### 3rd Scissor arms

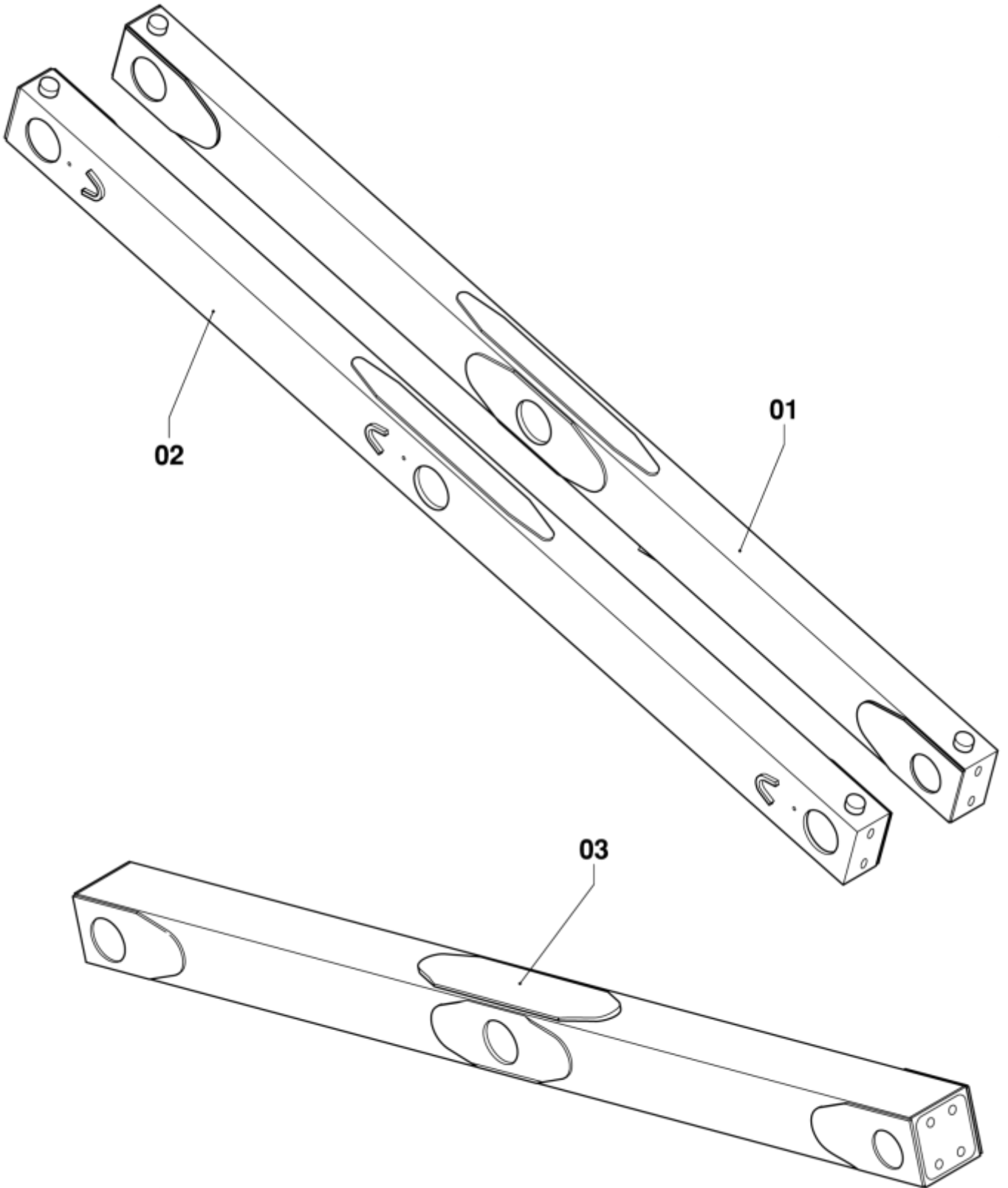



<b>Item</b>	<b>Qty</b>	<b>Part number</b>	<b>Description</b>
1	1	V-01-28-1	3 <sup>rd</sup> Outer scissor arm, Left
2	1	V-01-28-2	3 <sup>rd</sup> Outer scissor arm, Right
3	1	V-01-27	3 <sup>rd</sup> Inner scissor arm

### 4th Scissor arms

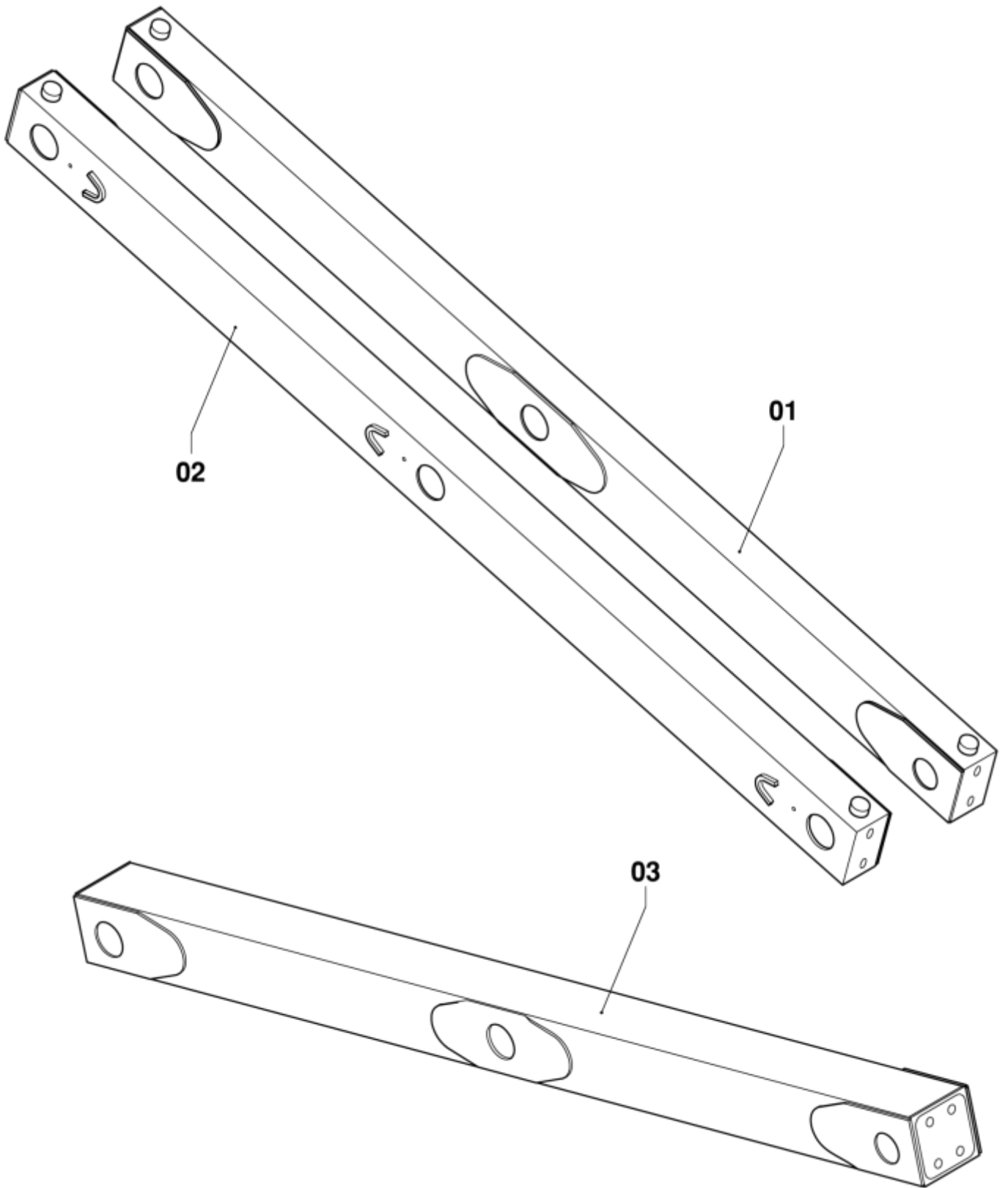

<b>Item</b>	<b>Qty</b>	<b>Part number</b>	<b>Description</b>
1	1	V-01-30-1	4 <sup>th</sup> Outer scissor arm, Left
2	1	V-01-30-2	4 <sup>th</sup> Outer scissor arm, Right
3	1	V-01-29	4 <sup>th</sup> Inner scissor arm

### 5th Scissor arms

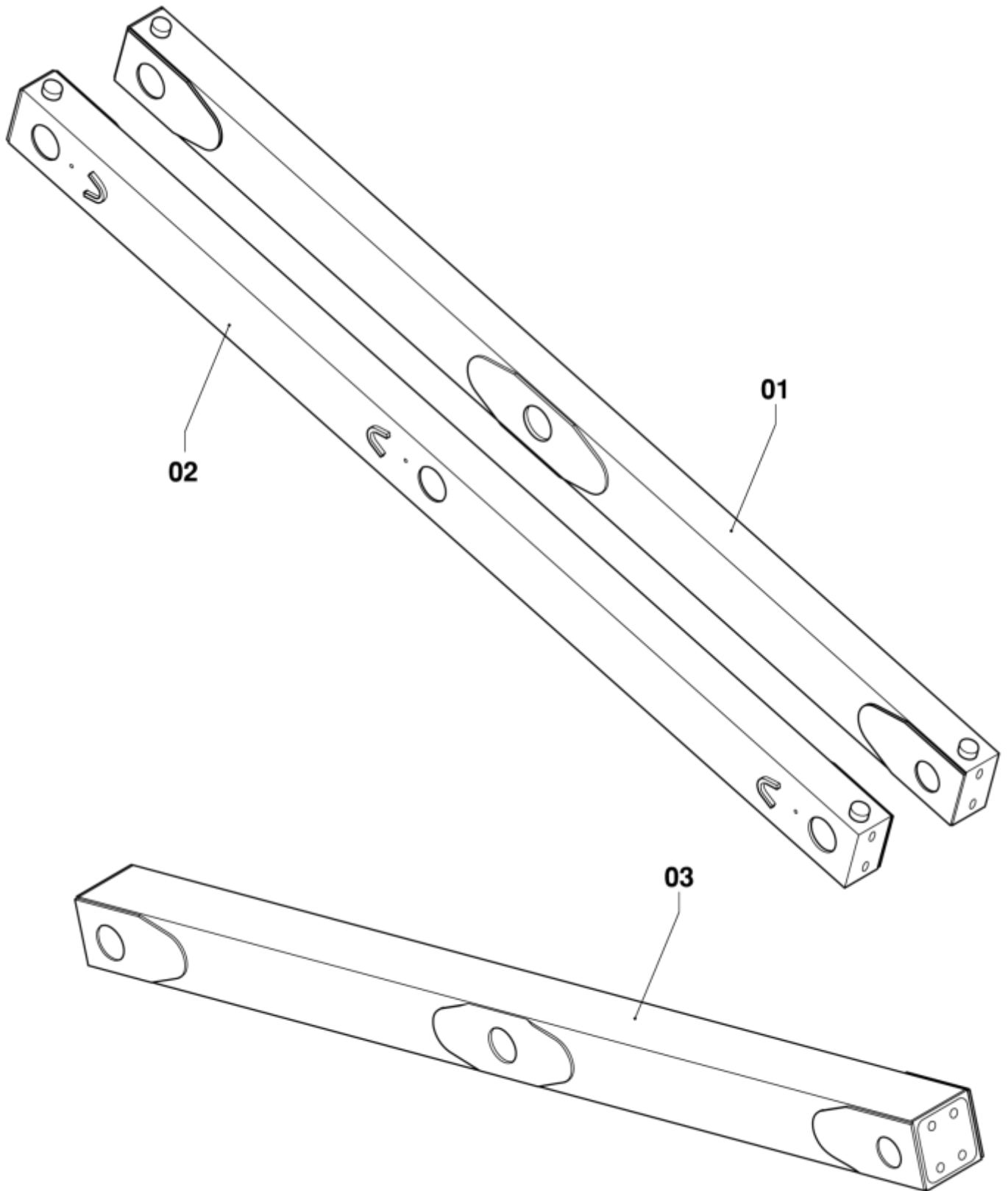

<b>Item</b>	<b>Qty</b>	<b>Part number</b>	<b>Description</b>
1	1	V165-01-32-1	5 <sup>th</sup> Outer scissor arm, Left
2	1	V165-01-32-2	5 <sup>th</sup> Outer scissor arm, Right
3	1	V165-01-31	5 <sup>th</sup> Inner scissor arm

### 6th Scissor arms

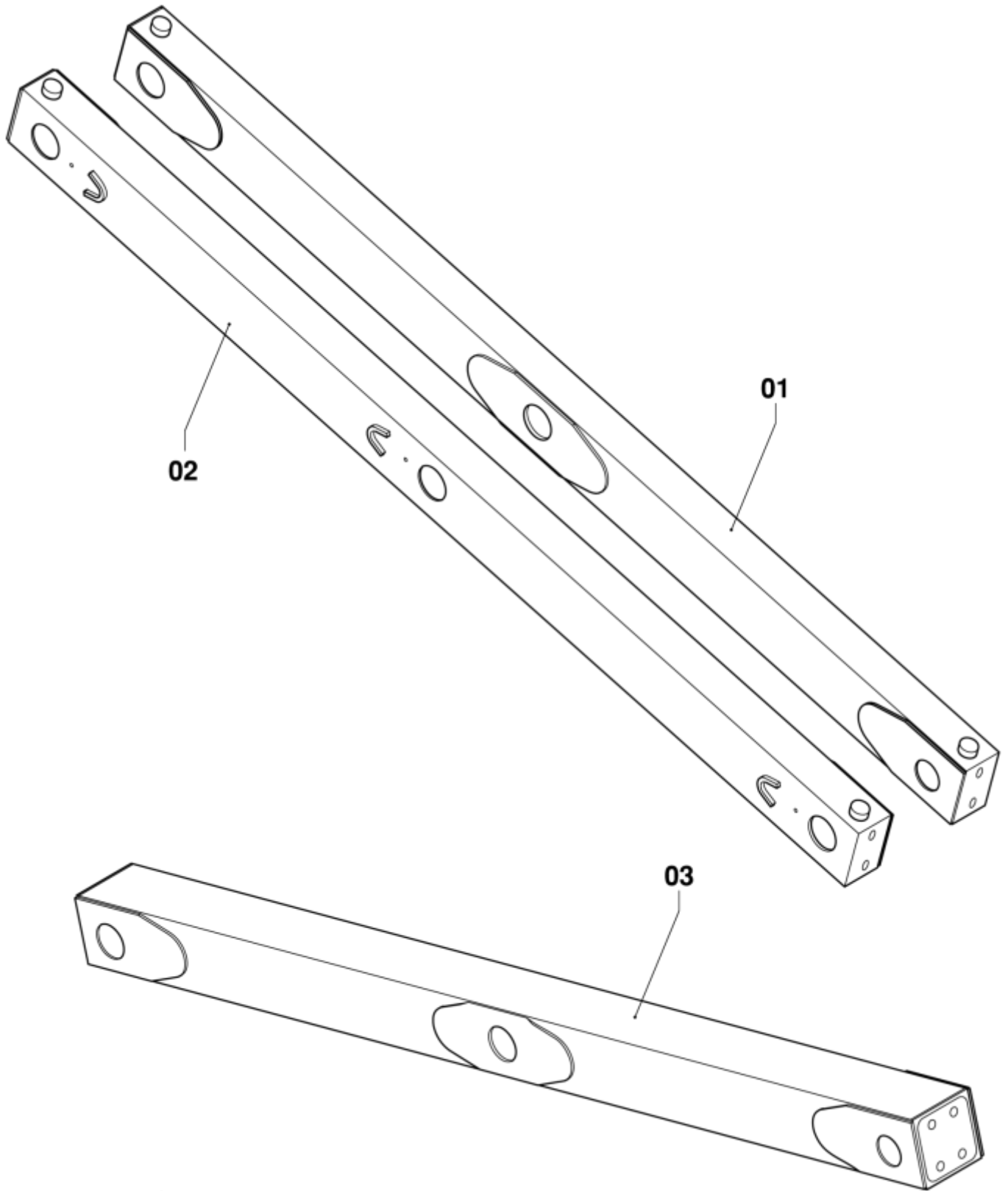

<b>Item</b>	<b>Qty</b>	<b>Part number</b>	<b>Description</b>
1	1	V-01-34-1	6 <sup>th</sup> Outer scissor arm, Left
2	1	V-01-34-2	6 <sup>th</sup> Outer scissor arm, Right
3	1	V-01-33	6 <sup>th</sup> Inner scissor arm

### Joint 1-21-22

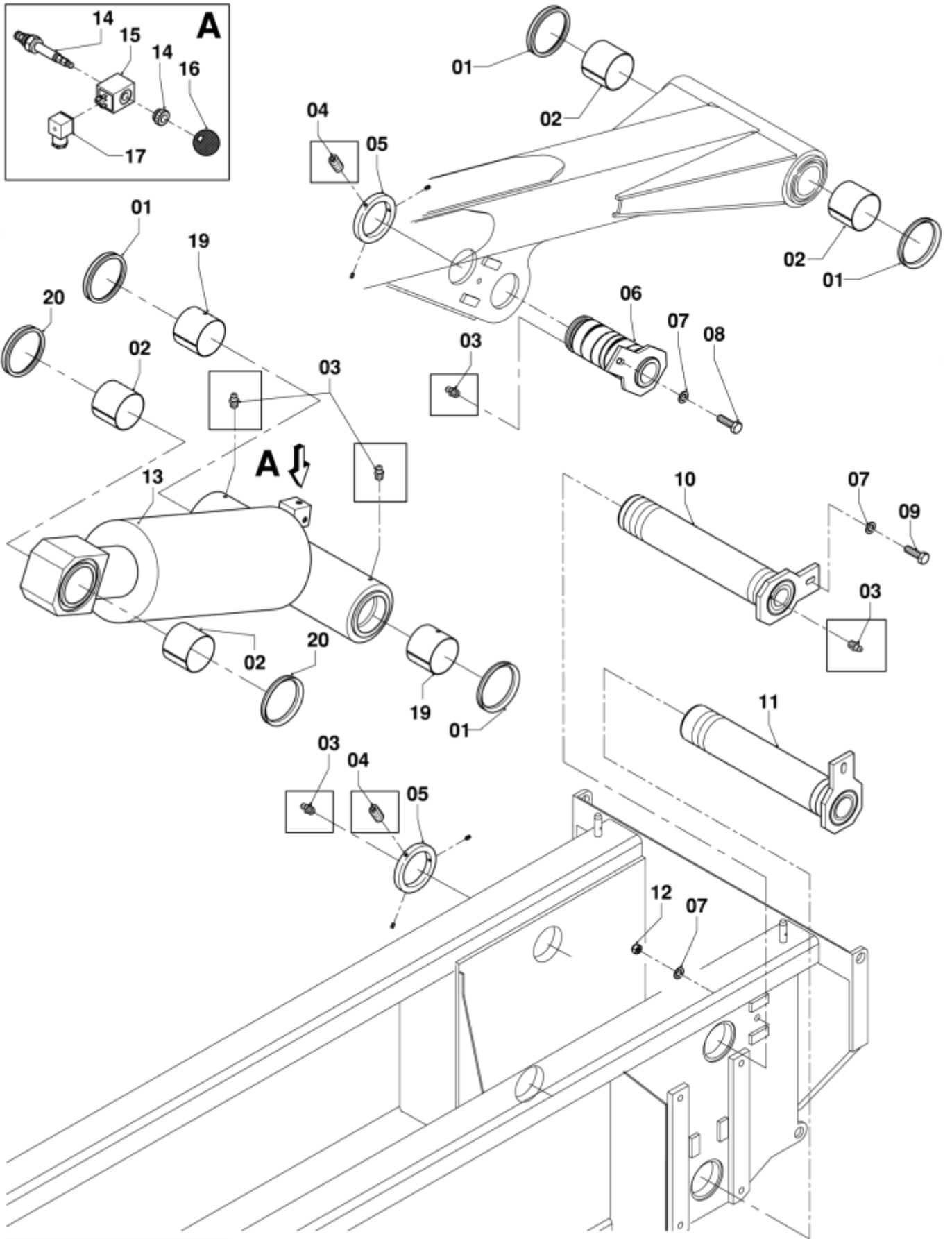



Item	Qty	Part number	Description
1	4	AFDICHT160A	Seal
2	4	FLAGER193	Bearing Ø 120 / L = 100
3	5	NIPPELM8x1,25	Grease nipple
4	6	07840.120.025	Screw, DIN 916
5	2	RING120	Retaining ring
6	1	V-01-40-1	Pin Ø 120 x 226
7	3	38130.160.001	Washer, DIN 125-A
8	1	01210.160.040	Bolt, DIN 933
9	1	01200.160.060	Bolt, DIN 931
10	1	V-01-40-2	Pin Ø 120 x 652
11	1	V-01-40-3	Pin Ø 120 x 642
12	1	12300.160.001	Nut, DIN 985
13	1	CIL475	Lift cylinder
14	1	VENT450A	Valve (emergency lowering)
15	1	SPOEL 24A	Coil
16	1	KNOP002	Emergency lowering button (red)
17	1	STEKKERKAP	Plug cap
18	2	AFDICHT180A	Seal
19	2	FLAGER193	Bearing Ø 120 / L = 100 (+ hole)
20	2	AFDICHT160S	Seal

## Joint 2

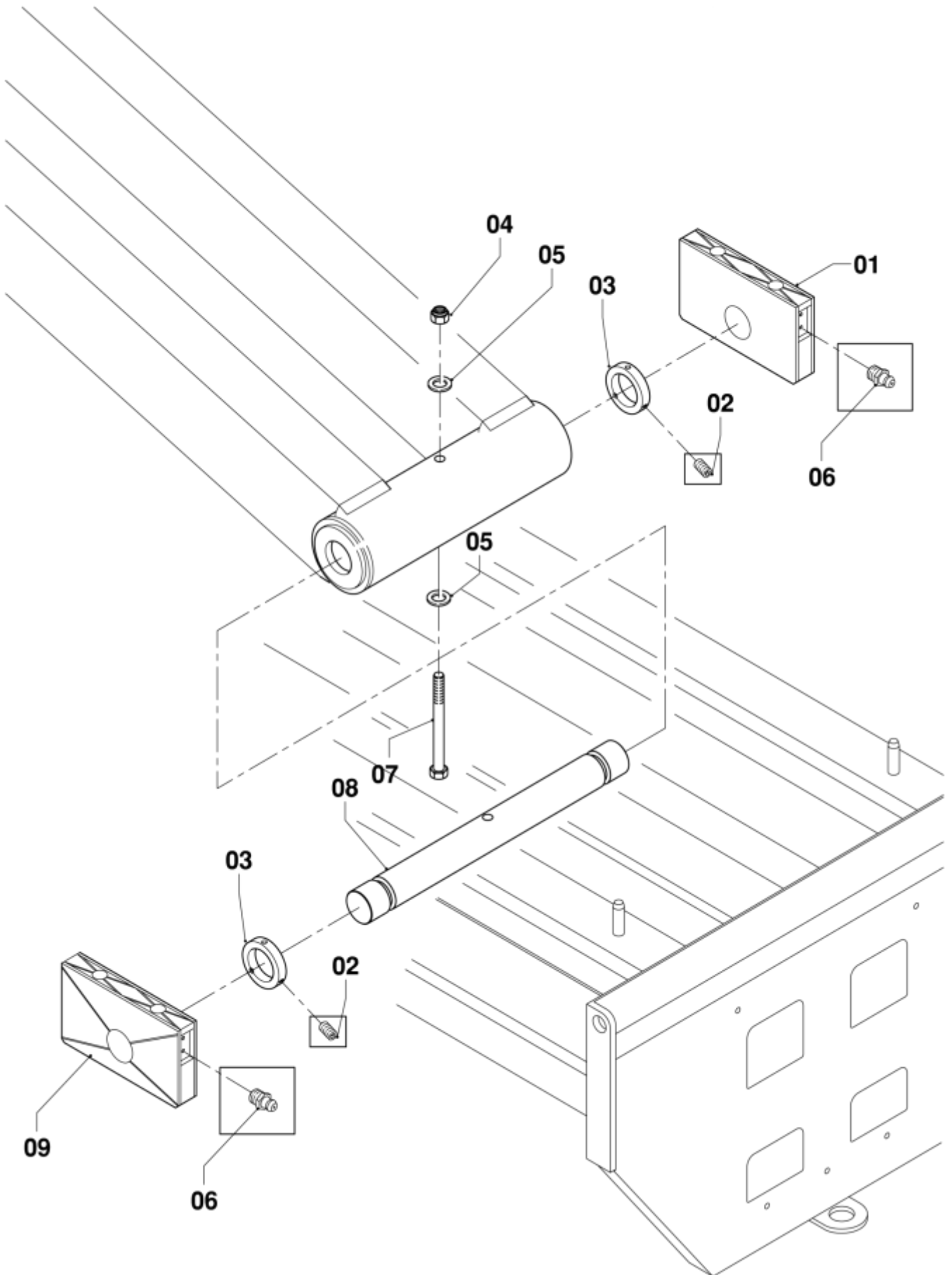

Item	Qty	Part number	Description
1	1	V-01-41-1	Sliding block L (GLYBLOK068)
2	6	07840.120.025	Screw, DIN 916
3	2	RING70	Retaining ring
4	1	12300.200.001	Nut, DIN 985
5	2	38130.200.001	Washer, DIN 125-A
6	4	NIPPELM12x1,25	Grease nipple
7	1	01200.200.220	Bolt, DIN 931
8	1	V-01-41-2	Pin Ø 70 x 708
9	1	V-01-41-3	Sliding block R (GLYBLOK069)

### Joint 15

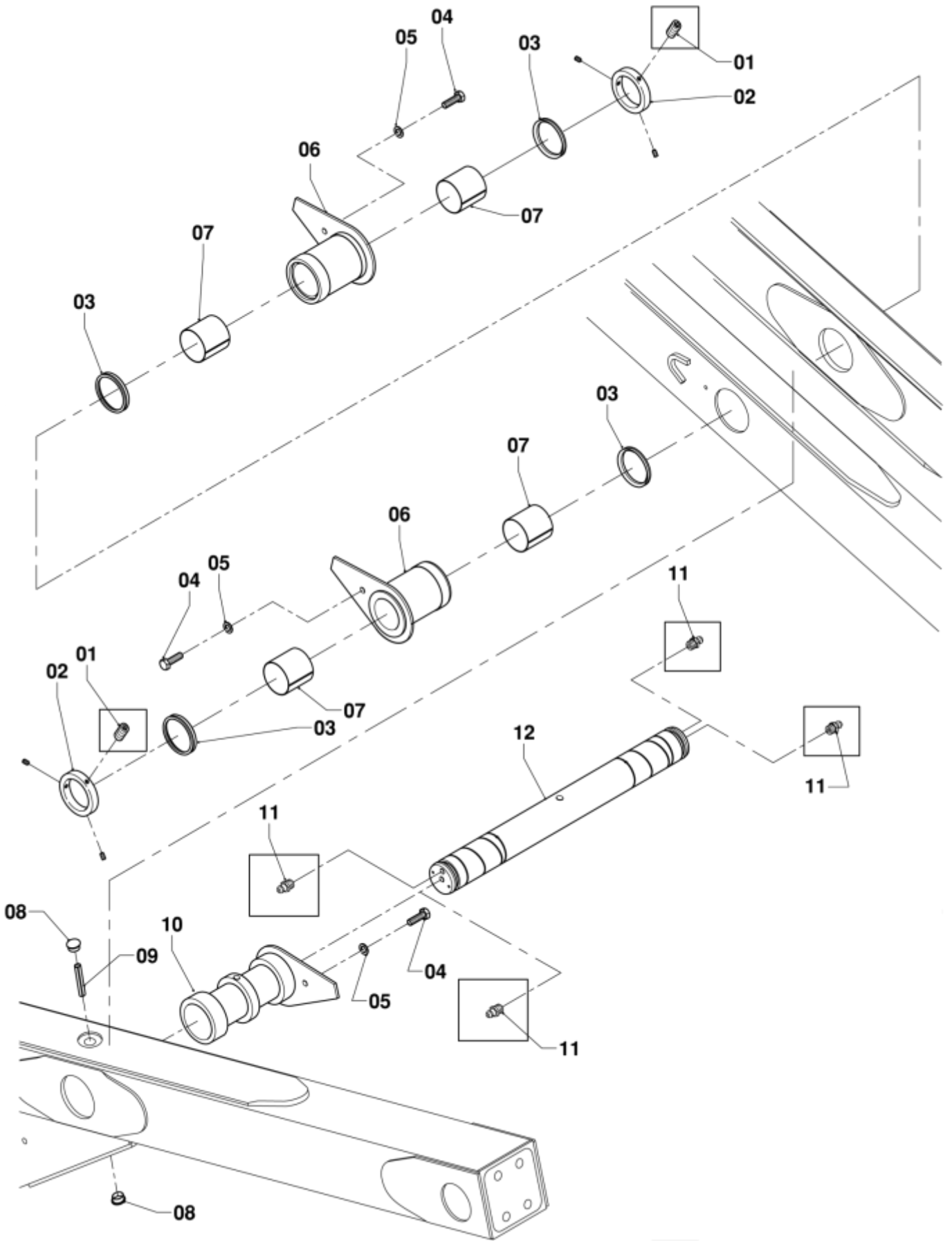

Item	Qty	Part number	Description
1	6	07840.100.020	Screw, DIN 916
2	2	RING90	Retaining ring
3	4	AFDICHT95A	Seal
4	3	01210.120.020	Bolt, DIN 933
5	3	38130.120.001	Washer, DIN 125-A
6	2	V-01-38-1	Bush (outer / 15)
7	4	FLAGER190	Bearing Ø 90 / L = 60
8	1	STO028	Plug
9	1	STIFT18 x120	Spring type straight pin
10	1	V-01-38-2	Bush (inner / 15)
11	4	NIPPELM8x1,25	Grease nipple
12	1	V-01-38-3	Pin Ø 90 x 586

### Joint 4

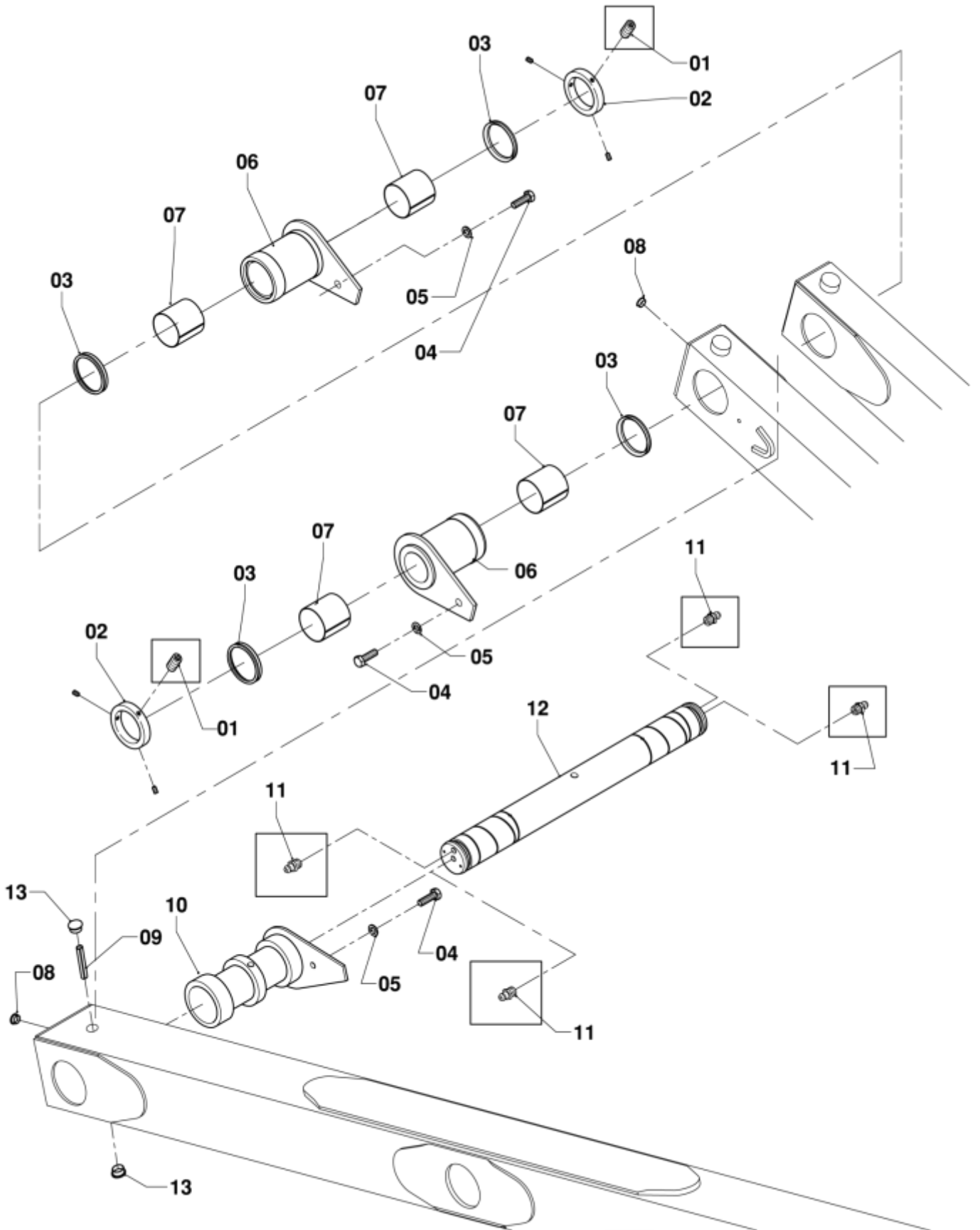

Item	Qty	Part number	Description
1	6	07840.100.020	Screw, DIN 916
2	2	RING90	Retaining ring
3	4	AFDICHT95A	Seal
4	3	01210.120.020	Bolt, DIN 933
5	3	38130.120.001	Washer, DIN 125-A
6	2	V-01-38-1	Bush (outer / 4)
7	4	FLAGER190	Bearing Ø 90 / L = 60
8	8	STO029	Plug
9	1	STIFT18 x120	Spring type straight pin
10	1	V-01-38-2	Bush (inner / 4)
11	4	NIPPELM8x1,25	Grease nipple
12	1	V-01-38-3	Pin Ø 90 x 586
13	2	STO028	Plug

### Joint 3

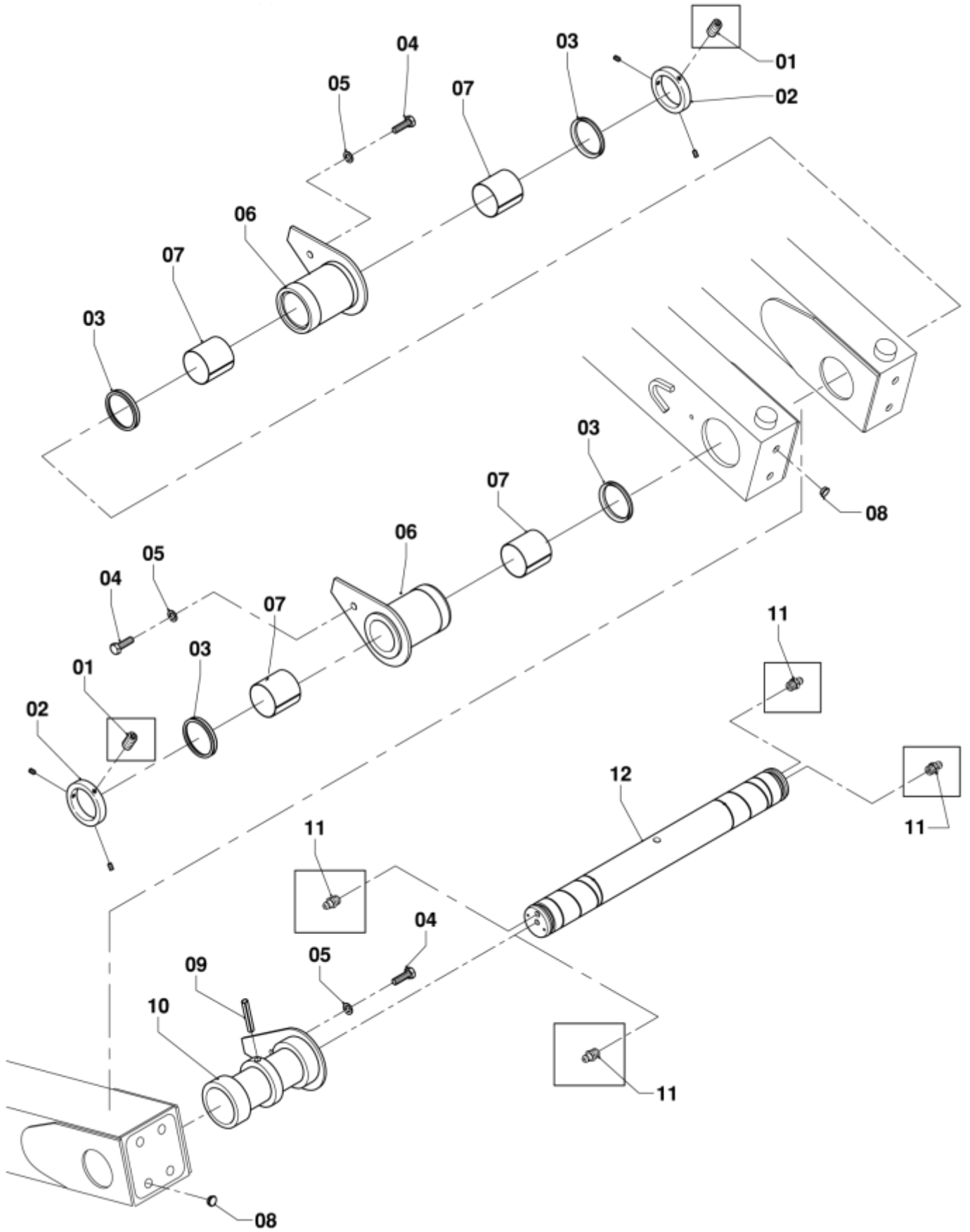



Item	Qty	Part number	Description
1	6	07840.100.020	Screw, DIN 916
2	2	RING90	Retaining ring
3	4	AFDICHT95A	Seal
4	3	01210.120.020	Bolt, DIN 933
5	3	38130.120.001	Washer, DIN 125-A
6	2	V-01-38-1	Bush (outer / 3)
7	4	FLAGER190	Bearing Ø 90 / L = 60
8	1	STO029	Plug
9	1	STIFT18 x120	Spring type straight pin
10	1	V-01-38-2	Bush (inner / 3)
11	4	NIPPELM8x1,25	Grease nipple
12	1	V-01-38-3	Pin Ø 90 x 586

### Joint 16

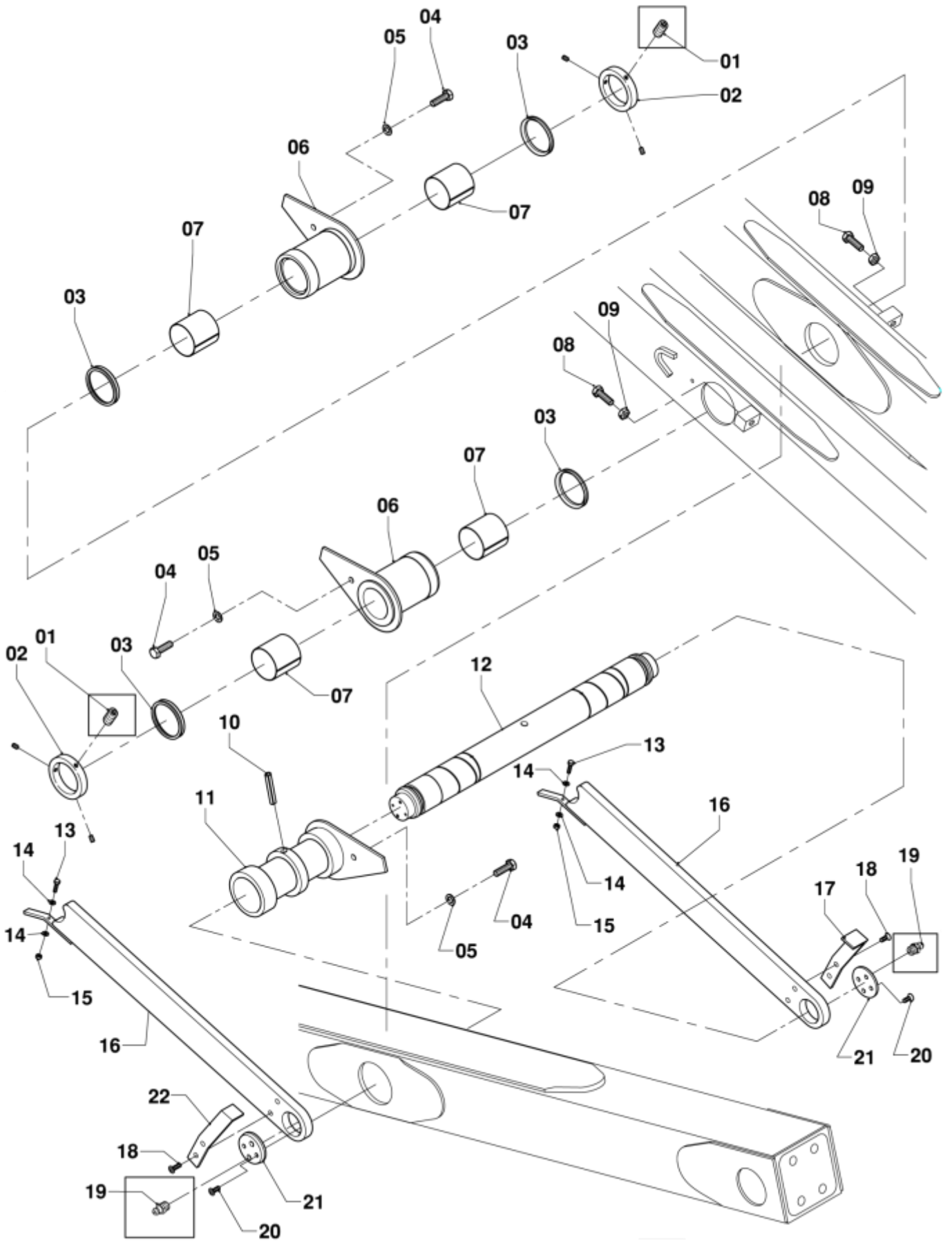

Item	Qty	Part number	Description
1	6	07840.120.025	Screw, DIN 916
2	2	RING100	Retaining ring
3	4	AFDICHT110A	Seal
4	3	01210.120.020	Bolt, DIN 933
5	3	38130.120.001	Washer, DIN 125-A
6	2	V-01-39-1	Bush (outer / 16)
7	4	FLAGER210	Bearing Ø 100 / L = 60
8	2	01210.120.100	Bolt, DIN 933
9	2	01300.120.001	Bolt, DIN 934
10	1	STIFT18 x120	Spring type straight pin
11	1	V-01-39-2	Bush (inner / 16)
12	1	V-01-39-3	Pin Ø100 x 641
13	2	01210.080.030	Bolt, DIN 934
14	4	38130.080.001	Washer, DIN 125-A
15	2	12300.080.001	Nut, DIN 985
16	2	V-02-45-1	Safety support
17	1	V-02-45-2	Strip, Left
18	4	07470.120.020	Bolt, DIN 7991
19	4	NIPPELM8x1,25	Grease nipple
20	4	07470.100.015	Bolt, DIN 7991
21	2	V-01-39-4	Locking plate
22	1	V-02-45-3	Strip, Right

### Joint 5

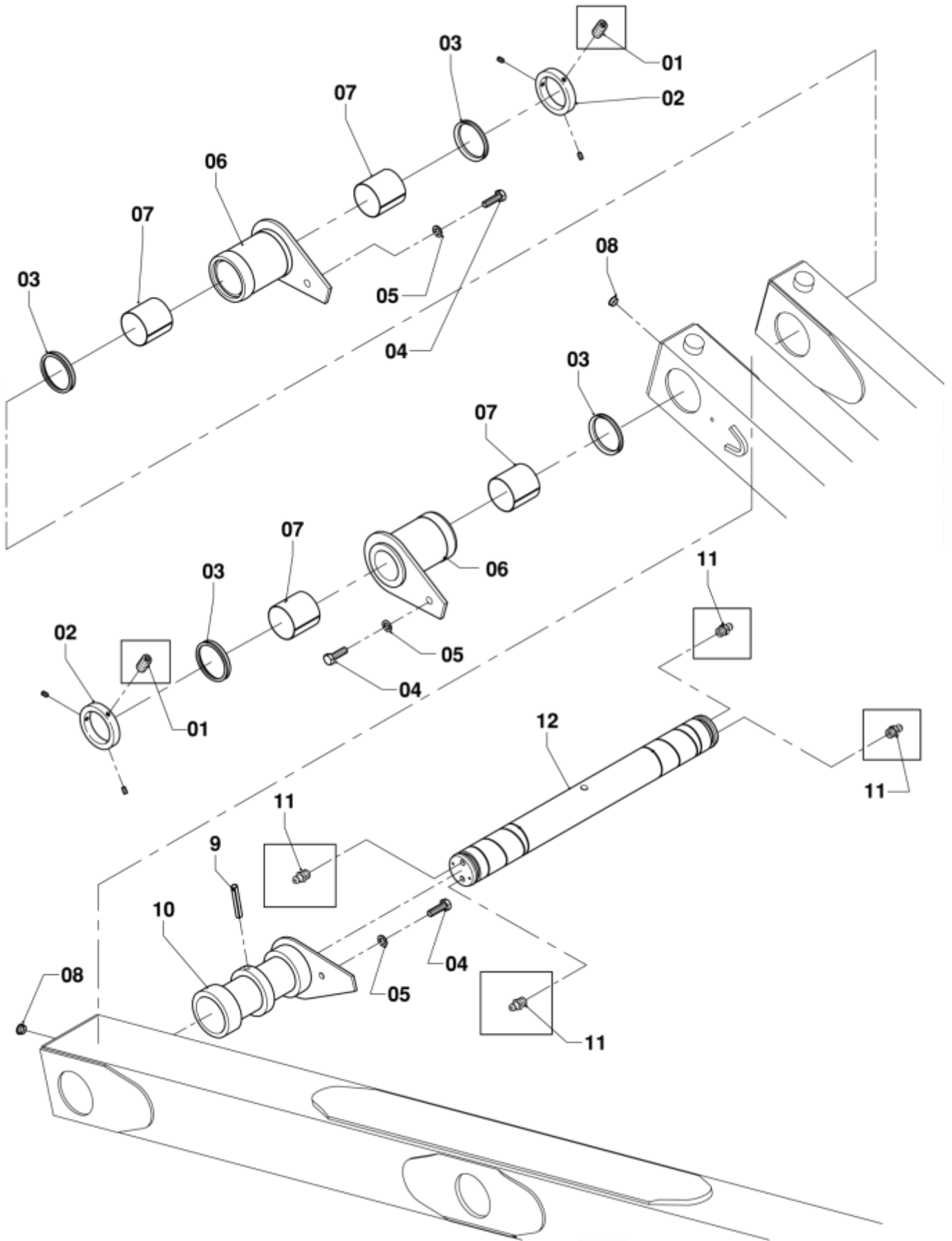

Item	Qty	Part number	Description
1	6	07840.120.020	Screw, DIN 916
2	2	RING75	Retaining ring
3	4	AFDICHT80A	Seal
4	3	01210.120.020	Bolt, DIN 933
5	3	38130.120.001	Washer, DIN 125-A
6	2	V-01-37-1	Bush (outer / 5)
7	4	FLAGER177	Bearing Ø 75 / L = 60
8	8	STO029	Plug
9	1	STIFT18 x100	Spring type straight pin
10	1	V-01-37-2	Bush (inner / 5)
11	4	NIPPELM8x1,25	Grease nipple
12	1	V-01-37-3	Pin Ø 75 x 586

### Joint 6

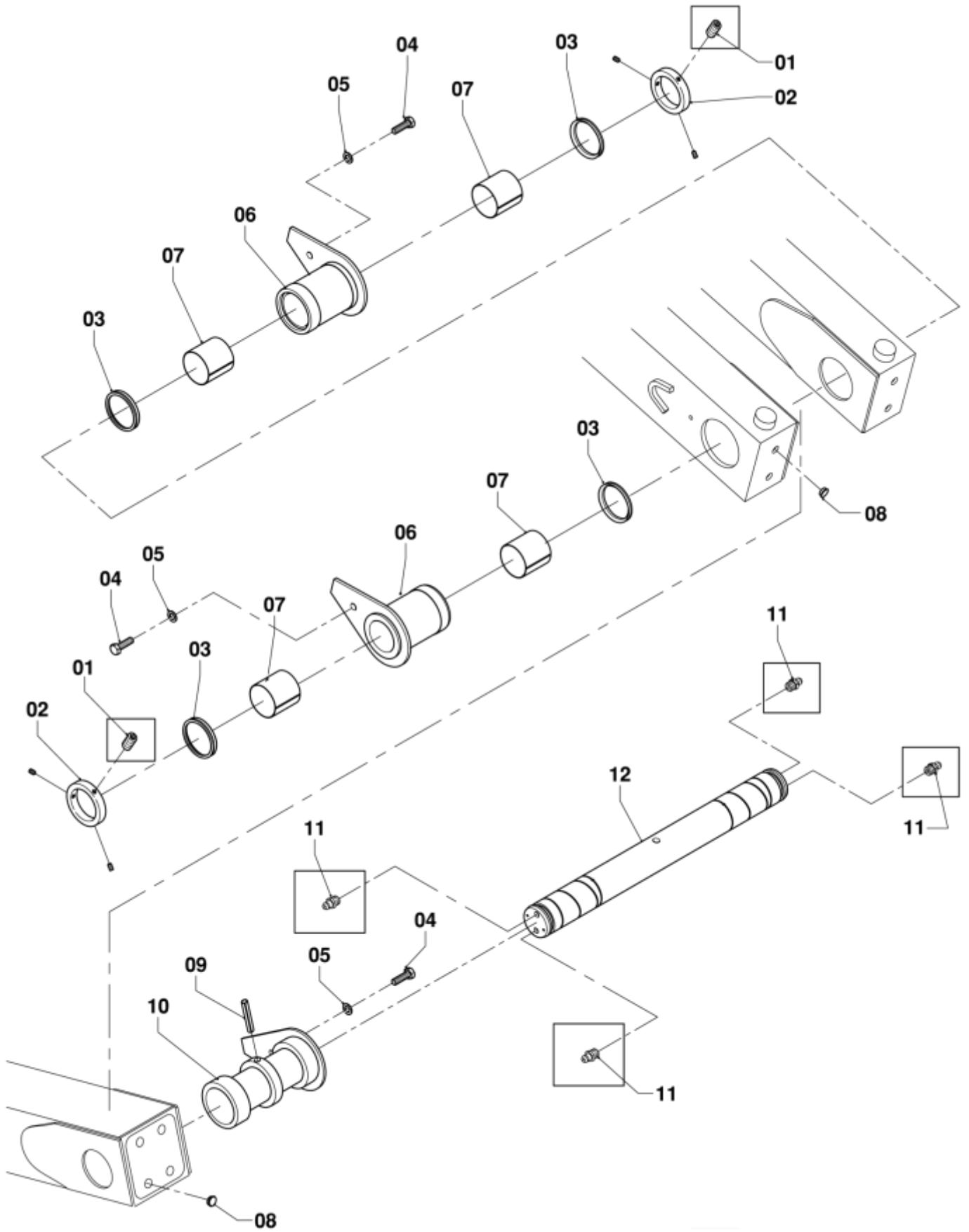

Item	Qty	Part number	Description
1	6	07840.120.020	Screw, DIN 916
2	2	RING75	Retaining ring
3	4	AFDICHT80A	Seal
4	3	01210.120.020	Bolt, DIN 933
5	3	38130.120.001	Washer, DIN 125-A
6	2	V-01-37-1	Bush (outer / 6)
7	4	FLAGER177	Bearing Ø 75 / L = 60
8	8	STO029	Plug
9	1	STIFT18 x100	Spring type straight pin
10	1	V-01-37-2	Bush (inner / 6)
11	4	NIPPELM8x1,25	Grease nipple
12	1	V-01-37-3	Pin Ø 75 x 586

### Joint 17

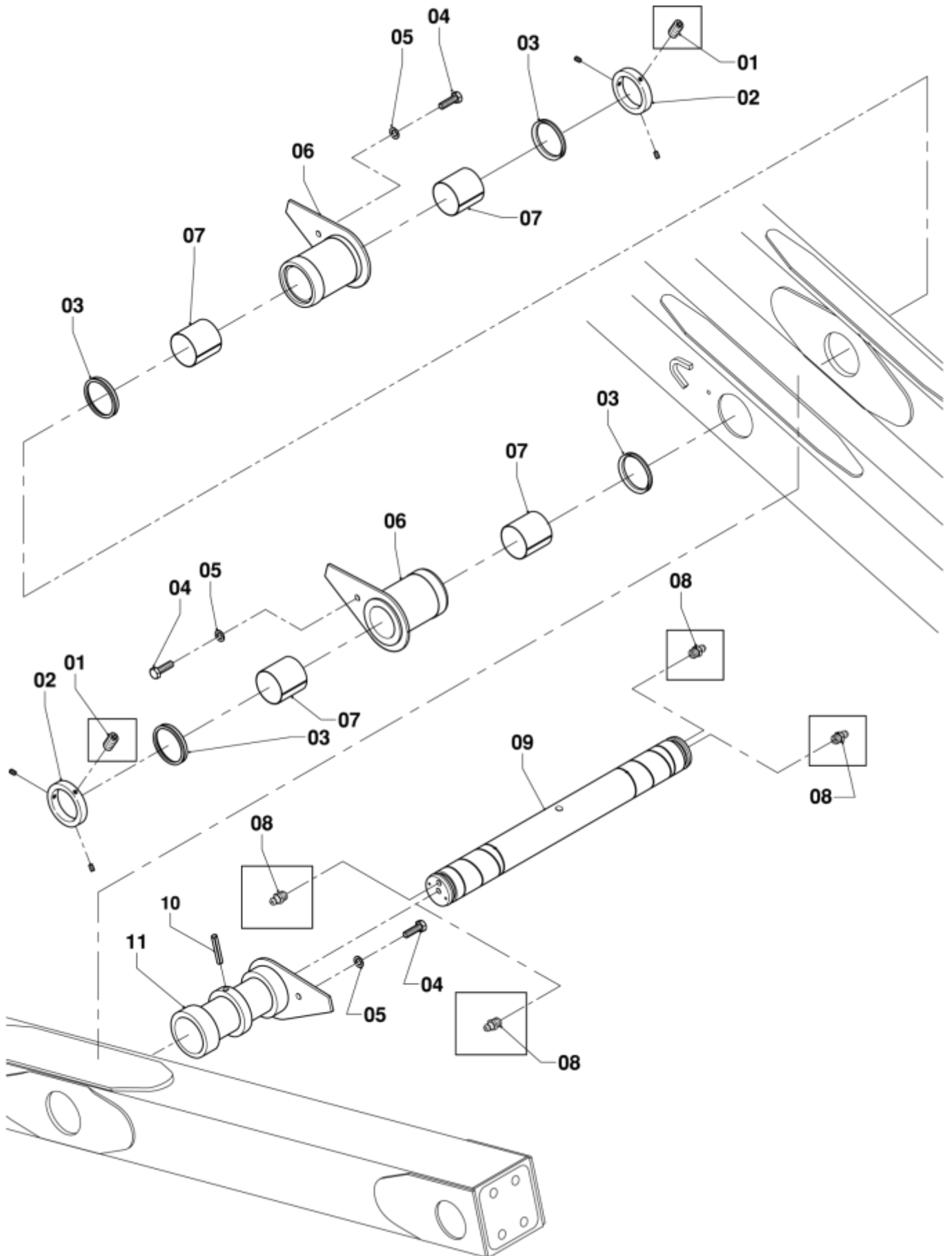



Item	Qty	Part number	Description
1	6	07840.120.020	Screw, DIN 916
2	2	RING90	Retaining ring
3	4	AFDICHT95A	Seal
4	3	01210.120.020	Bolt, DIN 933
5	3	38130.120.001	Washer, DIN 125-A
6	2	V-01-38-1	Bush (outer / 17)
7	4	FLAGER190	Bearing Ø 90 / L = 60
8	4	NIPPELM8x1,25	Grease nipple
9	1	V-01-38-2	Pin Ø 90 x 586
10	1	STIFT18 x120	Spring type straight pin
11	1	V-01-38-3	Bush (inner / 17)

### Joint 8

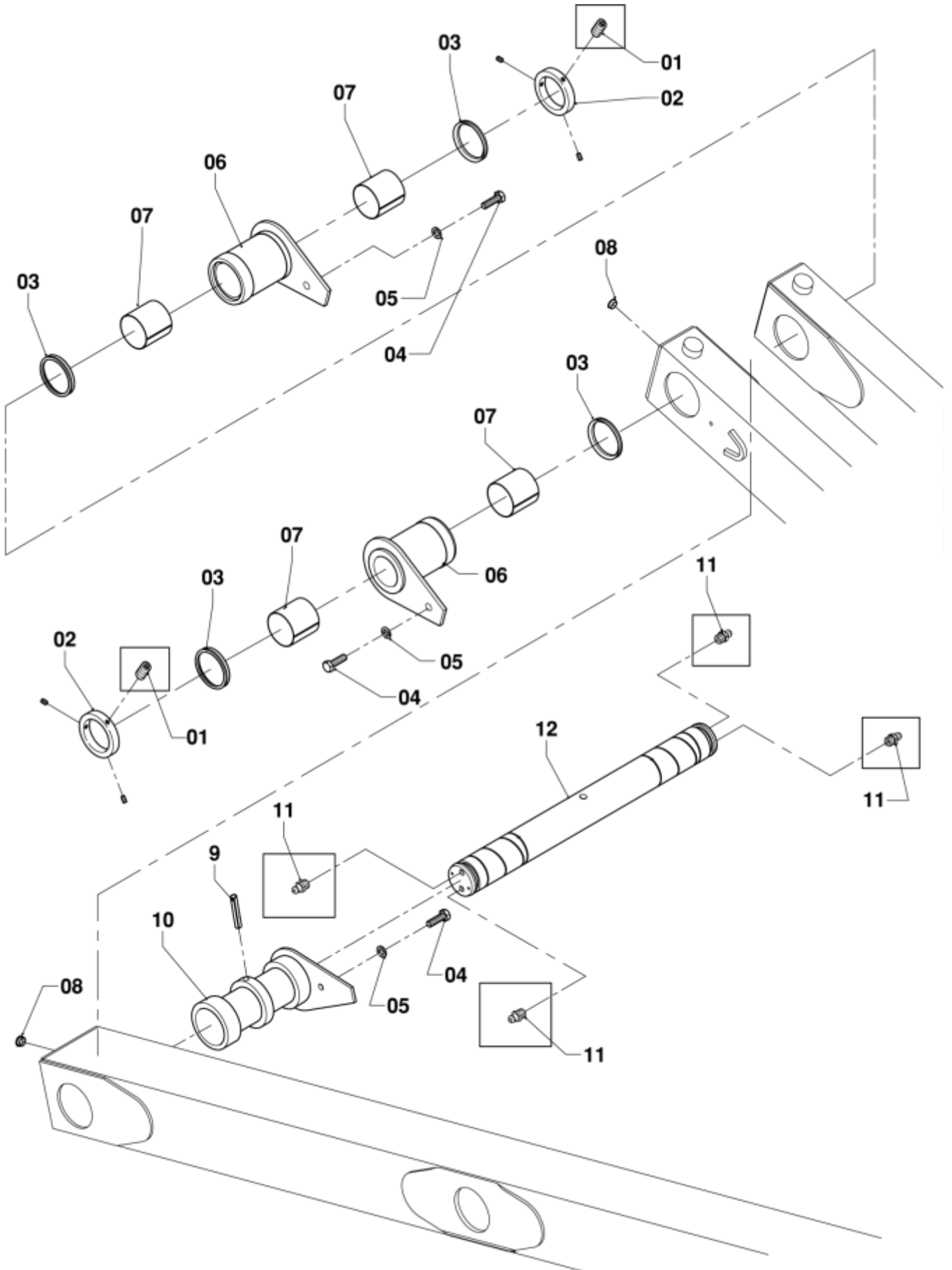

Item	Qty	Part number	Description
1	6	07840.120.020	Screw, DIN 916
2	2	RING75	Retaining ring
3	4	AFDICHT80A	Seal
4	3	01210.120.020	Bolt, DIN 933
5	3	38130.120.001	Washer, DIN 125-A
6	2	V-01-37-1	Bush (outer / 8)
7	4	FLAGER177	Bearing Ø 75 / L = 60
8	8	STO029	Plug
9	1	STIFT18 x100	Spring type straight pin
10	1	V-01-37-2	Bush (inner / 8)
11	4	NIPPELM8x1,25	Grease nipple
12	1	V-01-37-3	Pin Ø 75 x 586

### Joint 8-12

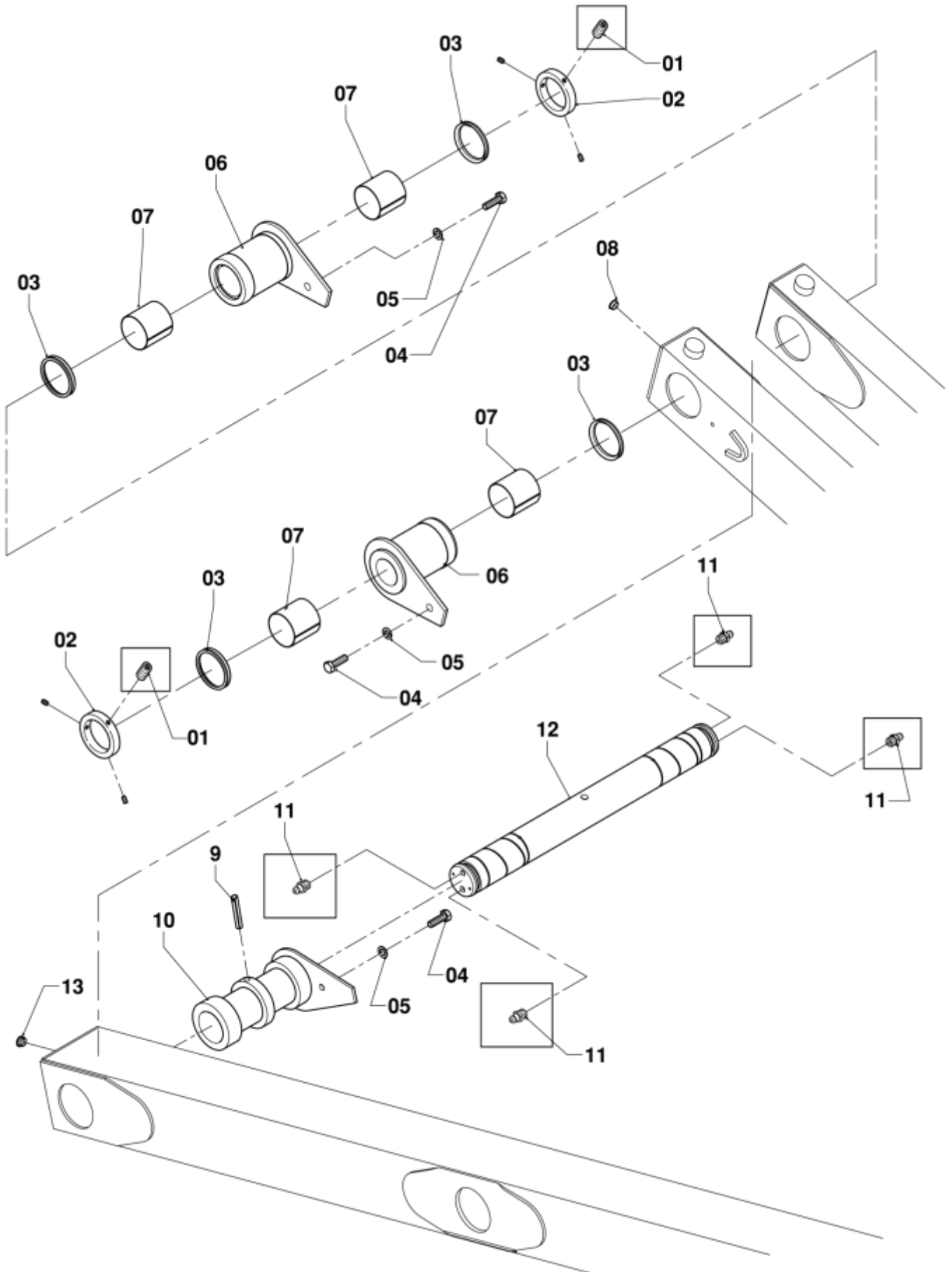

Item	Qty	Part number	Description
1	6	07840.100.020	Screw, DIN 916
2	2	RING60	Retaining ring
3	4	AFDICHT65A	Seal
4	3	01210.120.020	Bolt, DIN 933
5	3	38130.120.001	Washer, DIN 125-A
6	2	V120-01-42-1	Bush (outer / 8-12)
7	4	FLAGER177	Bearing Ø 60 / L = 60
8	4	STO029	Plug
9	1	STIFT18 x100	Spring type straight pin
10	1	V120-01-42-2	Bush (inner / 8-12)
11	4	NIPPELM8x1,25	Grease nipple
12	1	V120-01-42-3	Pin Ø 60 x 582
13	4	STO022	Plug

### Joint 7

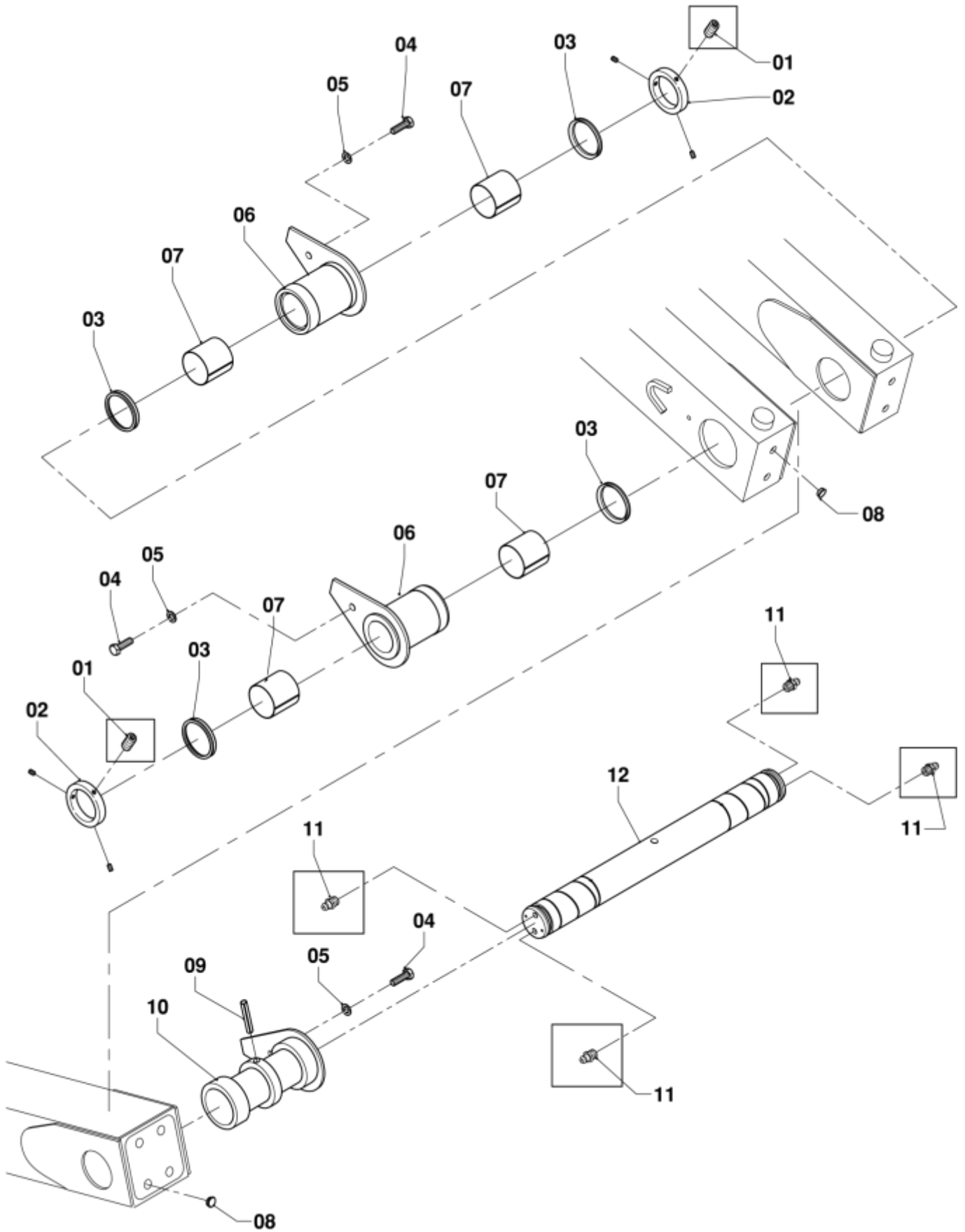

Item	Qty	Part number	Description
1	6	07840.120.020	Screw, DIN 916
2	2	RING75	Retaining ring
3	4	AFDICHT80A	Seal
4	3	01210.120.020	Bolt, DIN 933
5	3	38130.120.001	Washer, DIN 125-A
6	2	V-01-37-4	Bush (outer / 7)
7	4	FLAGER177	Bearing Ø 75 / L = 60
8	8	STO029	Plug
9	1	STIFT18 x100	Spring type straight pin
10	1	V-01-37-5	Bush (inner / 7)
11	4	NIPPELM8x1,25	Grease nipple
12	1	V-01-37-3	Pin Ø 75 x 586

### Joint 7-11

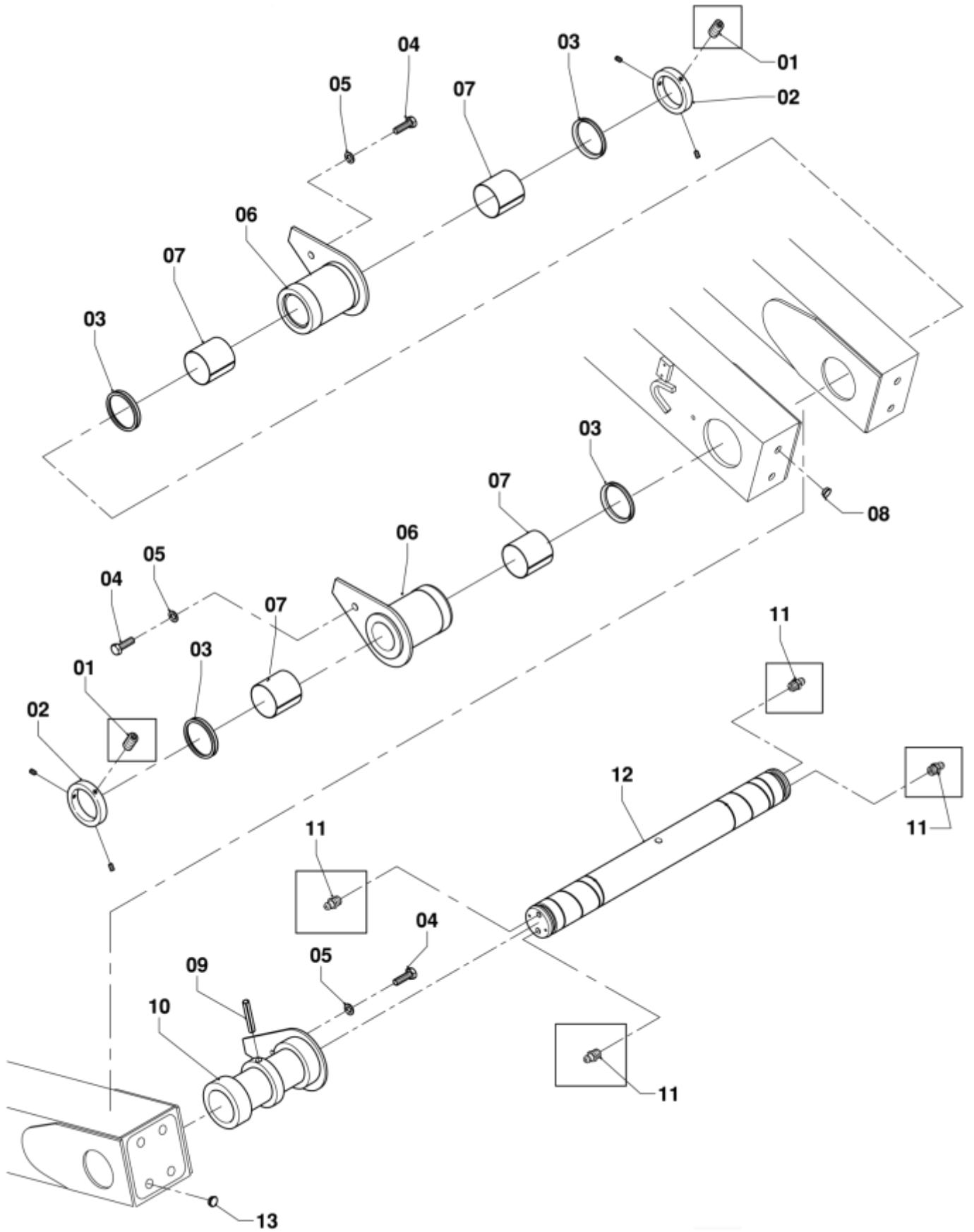



Item	Qty	Part number	Description
1	6	07840.100.020	Screw, DIN 916
2	2	RING60	Retaining ring
3	4	AFDICHT65A	Seal
4	3	01210.120.020	Bolt, DIN 933
5	3	38130.120.001	Washer, DIN 125-A
6	2	V120-01-42-1	Bush (outer / 7-11)
7	4	FLAGER177	Bearing Ø 60 / L = 60
8	4	STO029	Plug
9	1	STIFT18 x100	Spring type straight pin
10	1	V120-01-42-2	Bush (inner / 7-11)
11	4	NIPPELM8x1,25	Grease nipple
12	1	V120-01-42-3	Pin Ø 60 x 582
13	4	STO022	Plug

### Joint 18

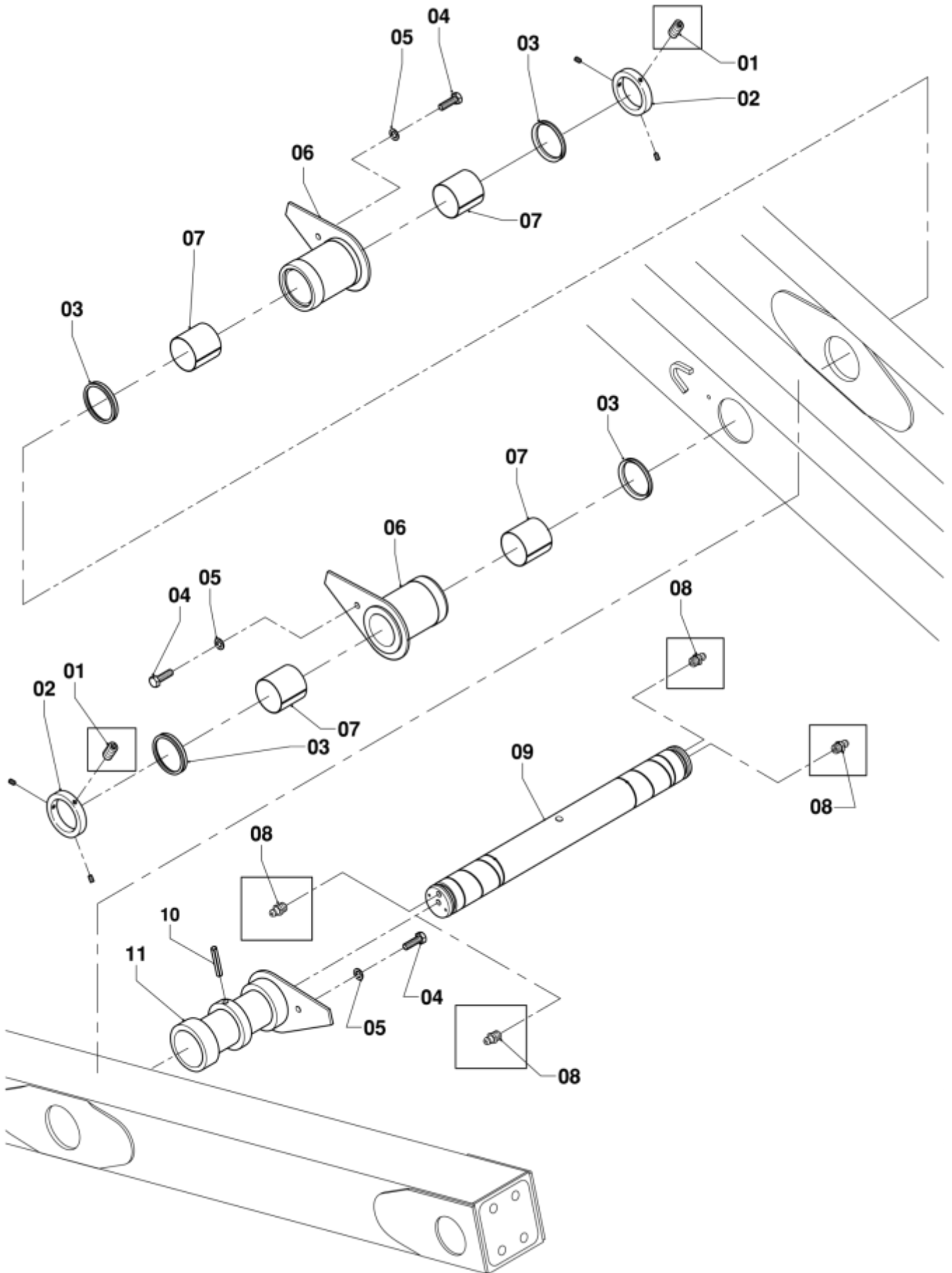

Item	Qty	Part number	Description
1	6	07840.120.020	Screw, DIN 916
2	2	RING75	Retaining ring
3	4	AFDICHT80A	Seal
4	3	01210.120.020	Bolt, DIN 933
5	3	38130.120.001	Washer, DIN 125-A
6	2	V-01-37-1	Bush (outer / 18)
7	4	FLAGER177	Bearing Ø 75 / L = 60
8	4	NIPPELM8x1,25	Grease nipple
9	1	V-01-37-2	Pin Ø 75 x 586
10	1	STIFT18 x100	Spring type straight pin
11	1	V-01-37-3	Bush (inner / 18)

### Joint 9

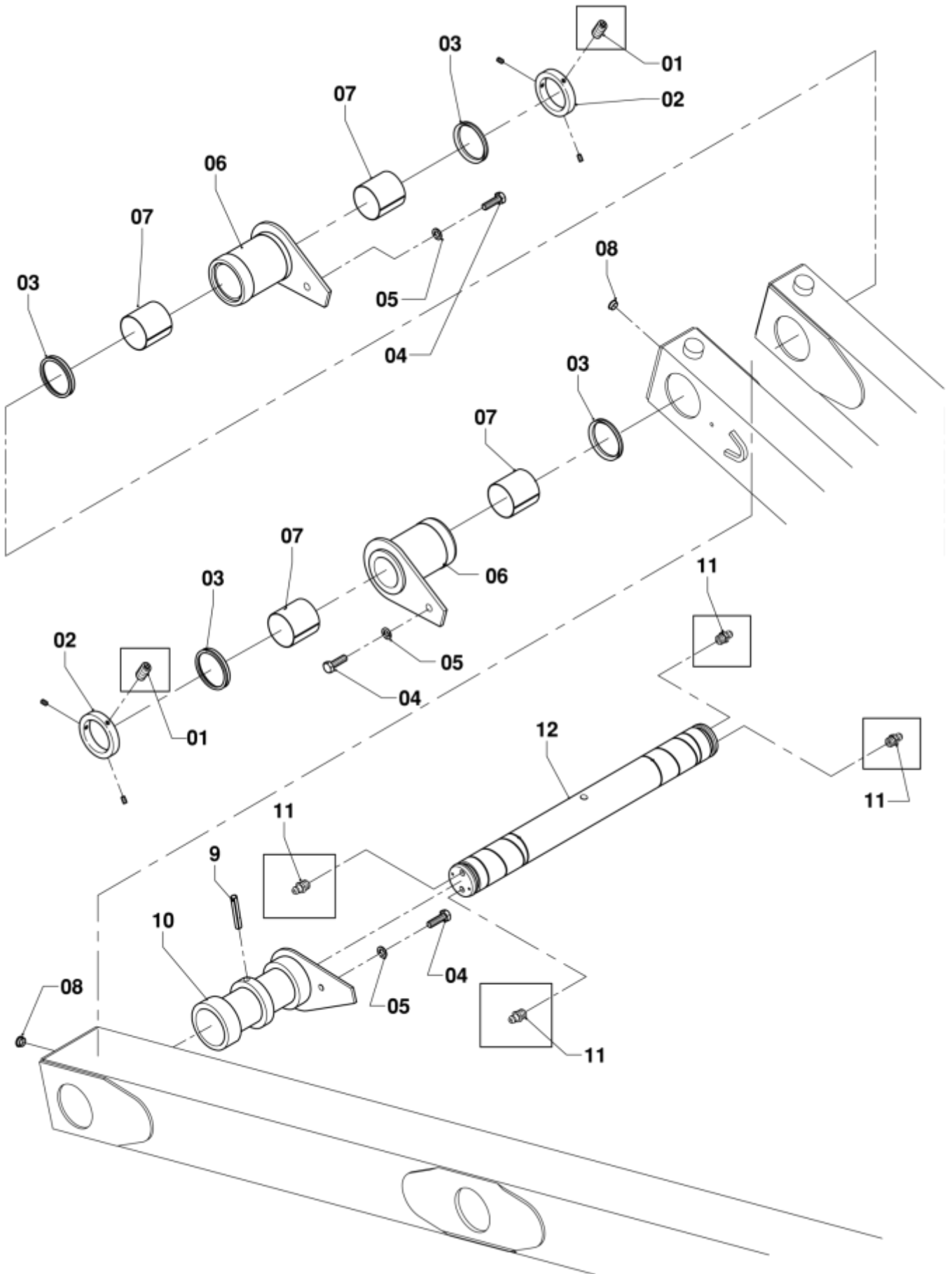

Item	Qty	Part number	Description
1	6	07840.100.020	Screw, DIN 916
2	2	RING60	Retaining ring
3	4	AFDICHT65A	Seal
4	3	01210.120.020	Bolt, DIN 933
5	3	38130.120.001	Washer, DIN 125-A
6	2	V165-01-42-1	Bush (outer / 9)
7	4	FLAGER156	Bearing Ø 60 / L = 60
8	8	STO029	Plug
9	1	STIFT18 x80	Spring type straight pin
10	1	V165-01-42-2	Bush (inner / 9)
11	4	NIPPELM8x1,25	Grease nipple
12	1	V165-01-42-3	Pin Ø 60 x 582

### Joint 10

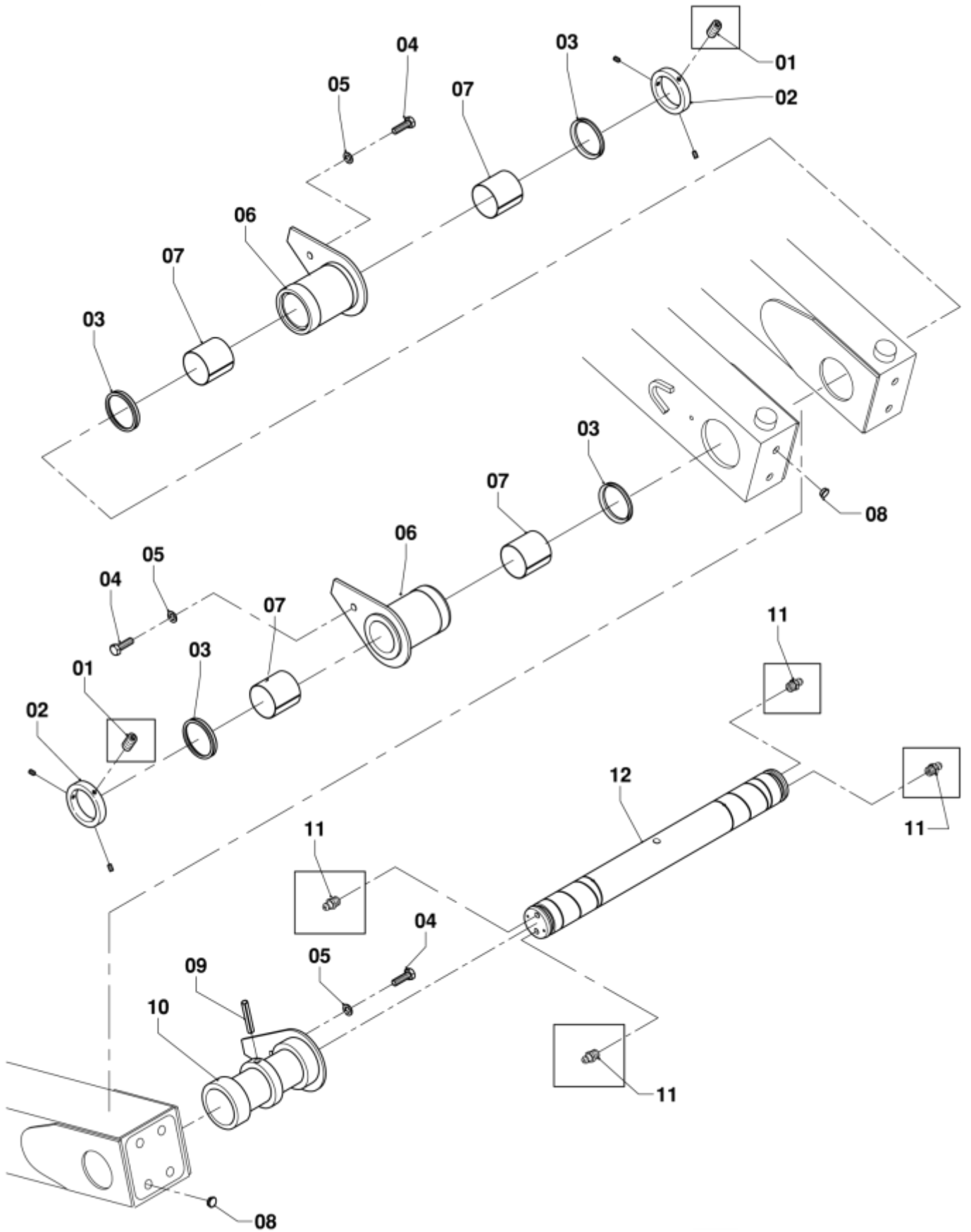

Item	Qty	Part number	Description
1	6	07840.100.020	Screw, DIN 916
2	2	RING60	Retaining ring
3	4	AFDICHT65A	Seal
4	3	01210.120.020	Bolt, DIN 933
5	3	38130.120.001	Washer, DIN 125-A
6	2	V165-01-42-1	Bush (outer / 10)
7	4	FLAGER156	Bearing Ø 60 / L = 60
8	8	STO029	Plug
9	1	STIFT18 x80	Spring type straight pin
10	1	V165-01-42-2	Bush (inner / 10)
11	4	NIPPELM8x1,25	Grease nipple
12	1	V165-01-42-3	Pin Ø 60 x 582

### Joint 9-12

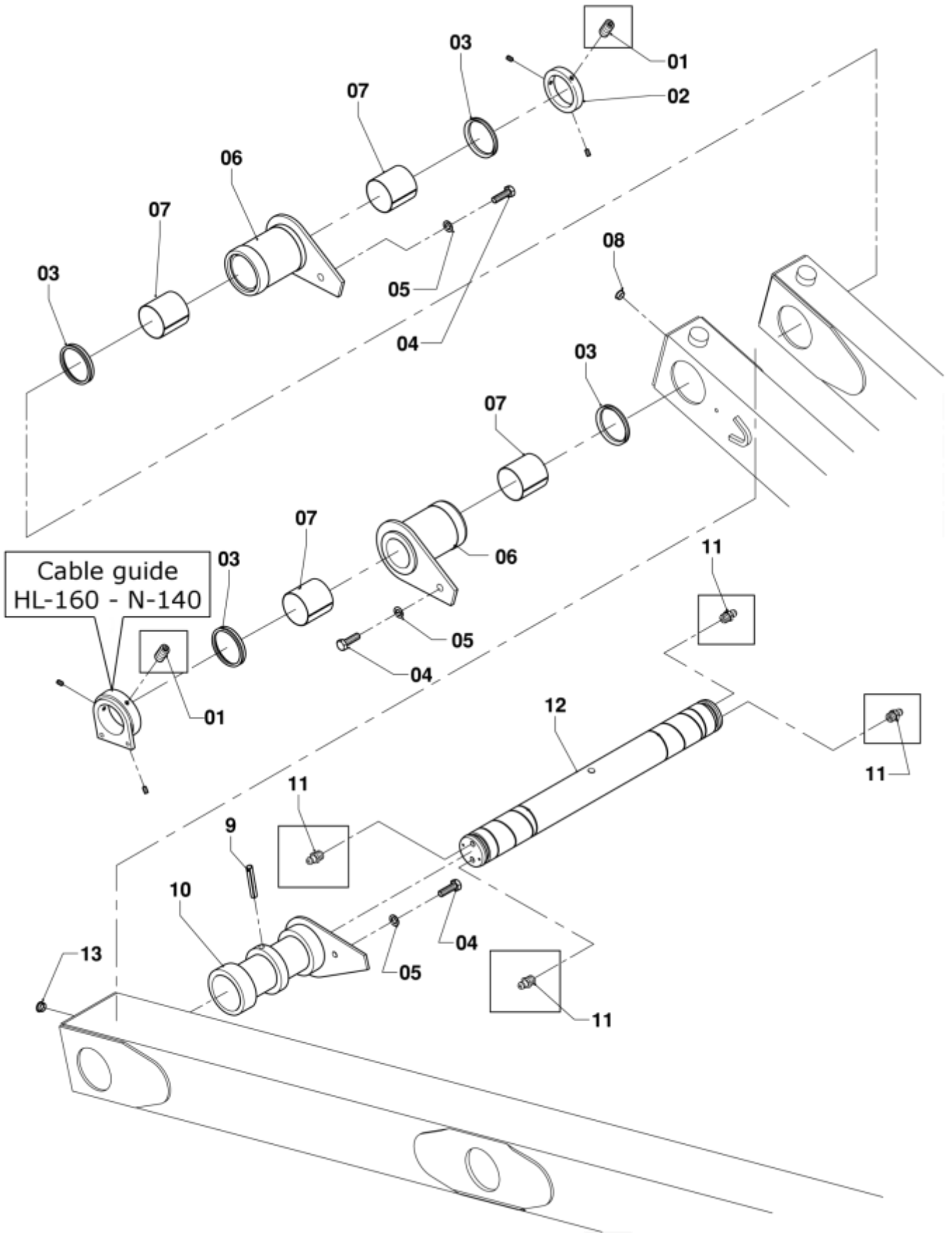



Item	Qty	Part number	Description
1	6	07840.100.020	Screw, DIN 916
2	1	RING60	Retaining ring
3	4	AFDICHT65A	Seal
4	3	01210.120.020	Bolt, DIN 933
5	3	38130.120.001	Washer, DIN 125-A
6	2	V140-01-42-1	Bush (outer / 9-12)
7	4	FLAGER156	Bearing Ø 60 / L = 60
8	4	STO029	Plug
9	1	STIFT18 x80	Spring type straight pin
10	1	V140-01-42-2	Bush (inner / 9-12)
11	4	NIPPELM8x1,25	Grease nipple
12	1	V140-01-42-3	Pin Ø 60 x 582
13	4	STO022	Plug

### Joint 10-11

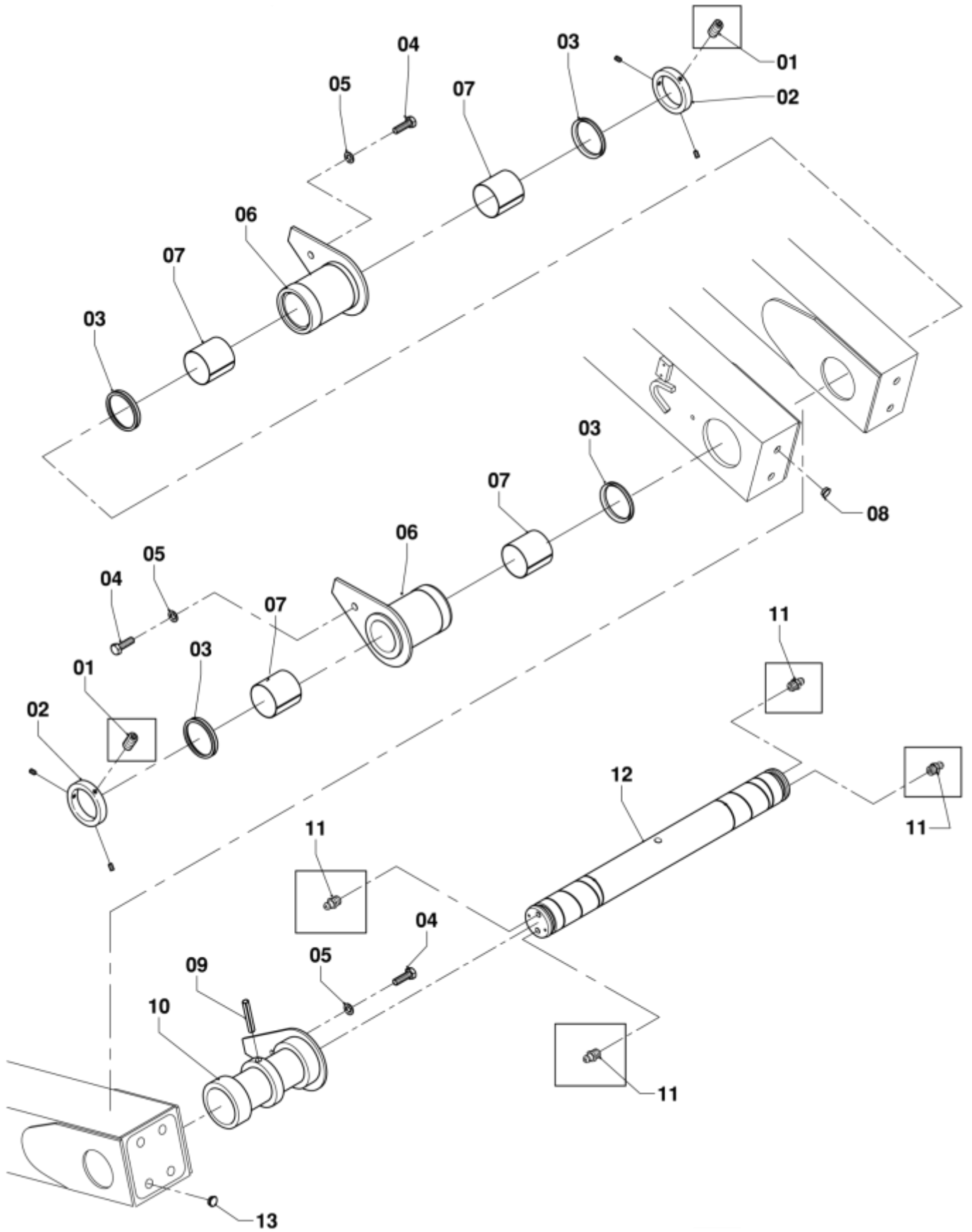

Item	Qty	Part number	Description
1	6	07840.100.020	Screw, DIN 916
2	1	RING60	Retaining ring
3	4	AFDICHT65A	Seal
4	3	01210.120.020	Bolt, DIN 933
5	3	38130.120.001	Washer, DIN 125-A
6	2	V140-01-42-1	Bush (outer / 10-11)
7	4	FLAGER156	Bearing Ø 60 / L = 60
8	4	STO029	Plug
9	1	STIFT18 x80	Spring type straight pin
10	1	V140-01-42-2	Bush (inner / 10-11)
11	4	NIPPELM8x1,25	Grease nipple
12	1	V140-01-42-3	Pin Ø 60 x 582
13	4	STO022	Plug

### Joint 19

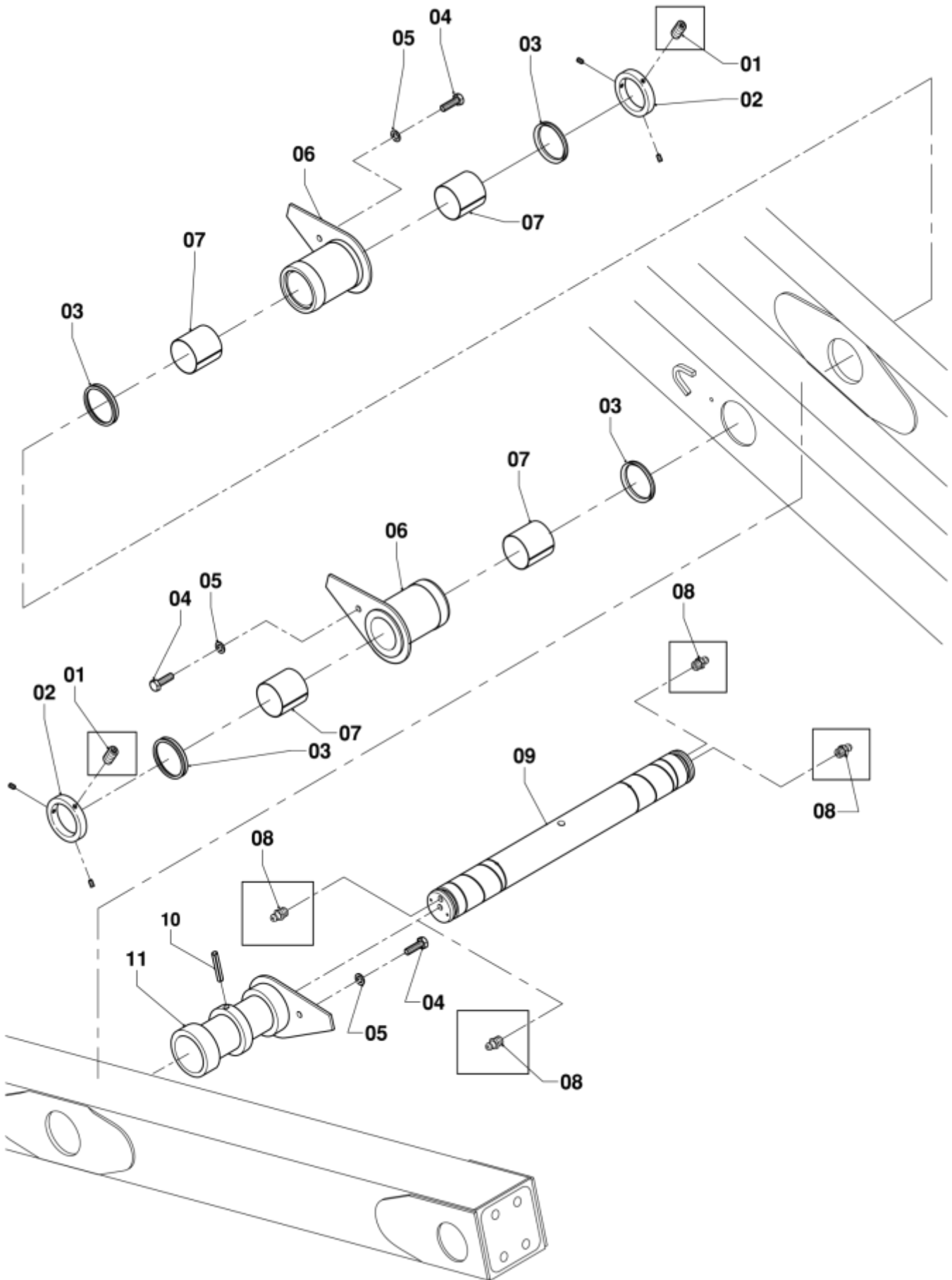

Item	Qty	Part number	Description
1	6	07840.100.020	Screw, DIN 916
2	2	RING60	Retaining ring
3	4	AFDICHT65A	Seal
4	3	01210.120.020	Bolt, DIN 933
5	3	38130.120.001	Washer, DIN 125-A
6	2	V165-01-42-1	Bush (outer / 19)
7	4	FLAGER156	Bearing Ø 60 / L = 60
8	4	NIPPELM8x1,25	Grease nipple
9	1	V165-01-42-2	Pin Ø 60 x 582
10	1	STIFT18 x80	Spring type straight pin
11	1	V165-01-42-3	Bush (inner / 19)

### Joint 12

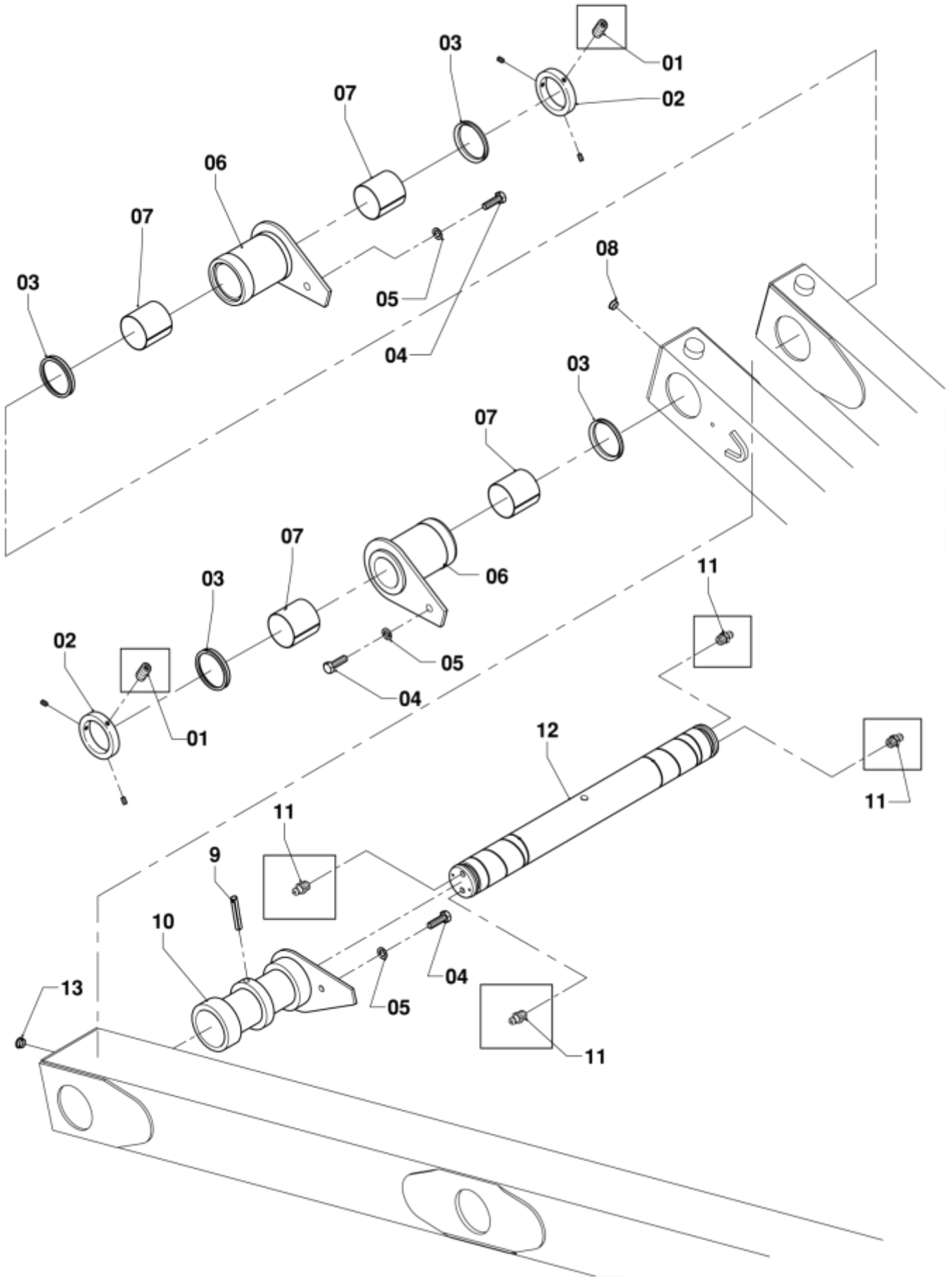

Item	Qty	Part number	Description
1	6	07840.100.020	Screw, DIN 916
2	1	RING60	Retaining ring
3	4	AFDICHT65A	Seal
4	3	01210.120.020	Bolt, DIN 933
5	3	38130.120.001	Washer, DIN 125-A
6	2	V165-01-42-1	Bush (outer / 12)
7	4	FLAGER156	Bearing Ø 60 / L = 60
8	4	STO029	Plug
9	1	STIFT18 x80	Spring type straight pin
10	1	V165-01-42-2	Bush (inner / 12)
11	4	NIPPELM8x1,25	Grease nipple
12	1	V165-01-42-3	Pin Ø 60 x 582
13	4	STO022	Plug

### Joint 11

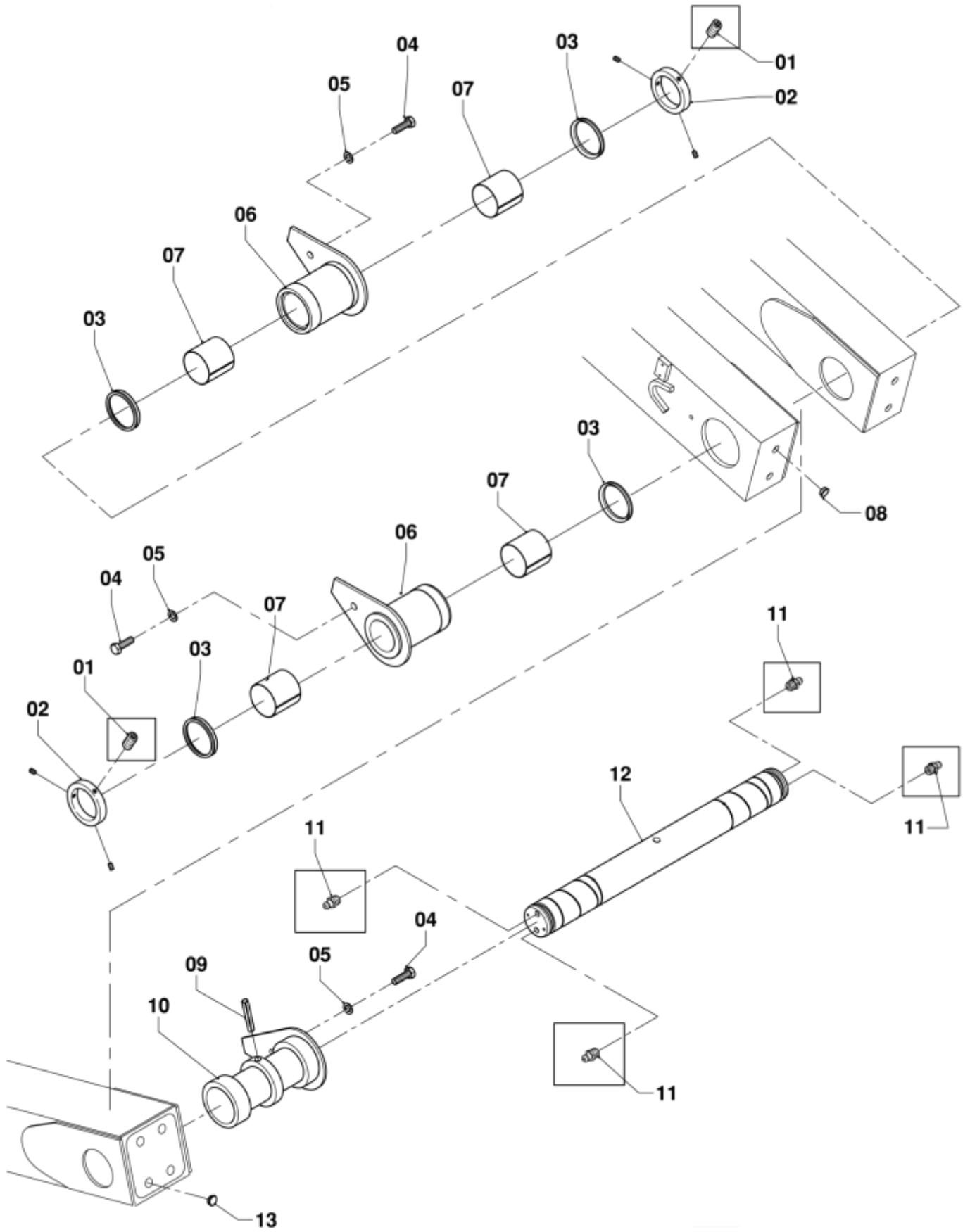



Item	Qty	Part number	Description
1	6	07840.100.020	Screw, DIN 916
2	2	RING60	Retaining ring
3	4	AFDICHT65A	Seal
4	3	01210.120.020	Bolt, DIN 933
5	3	38130.120.001	Washer, DIN 125-A
6	2	V165-01-42-1	Bush (outer / 11)
7	4	FLAGER156	Bearing Ø 60 / L = 60
8	4	STO029	Plug
9	1	STIFT18 x80	Spring type straight pin
10	1	V165-01-42-2	Bush (inner / 11)
11	4	NIPPELM8x1,25	Grease nipple
12	1	V165-01-42-3	Pin Ø 60 x 582
13	4	STO022	Plug

### Joint 20-A

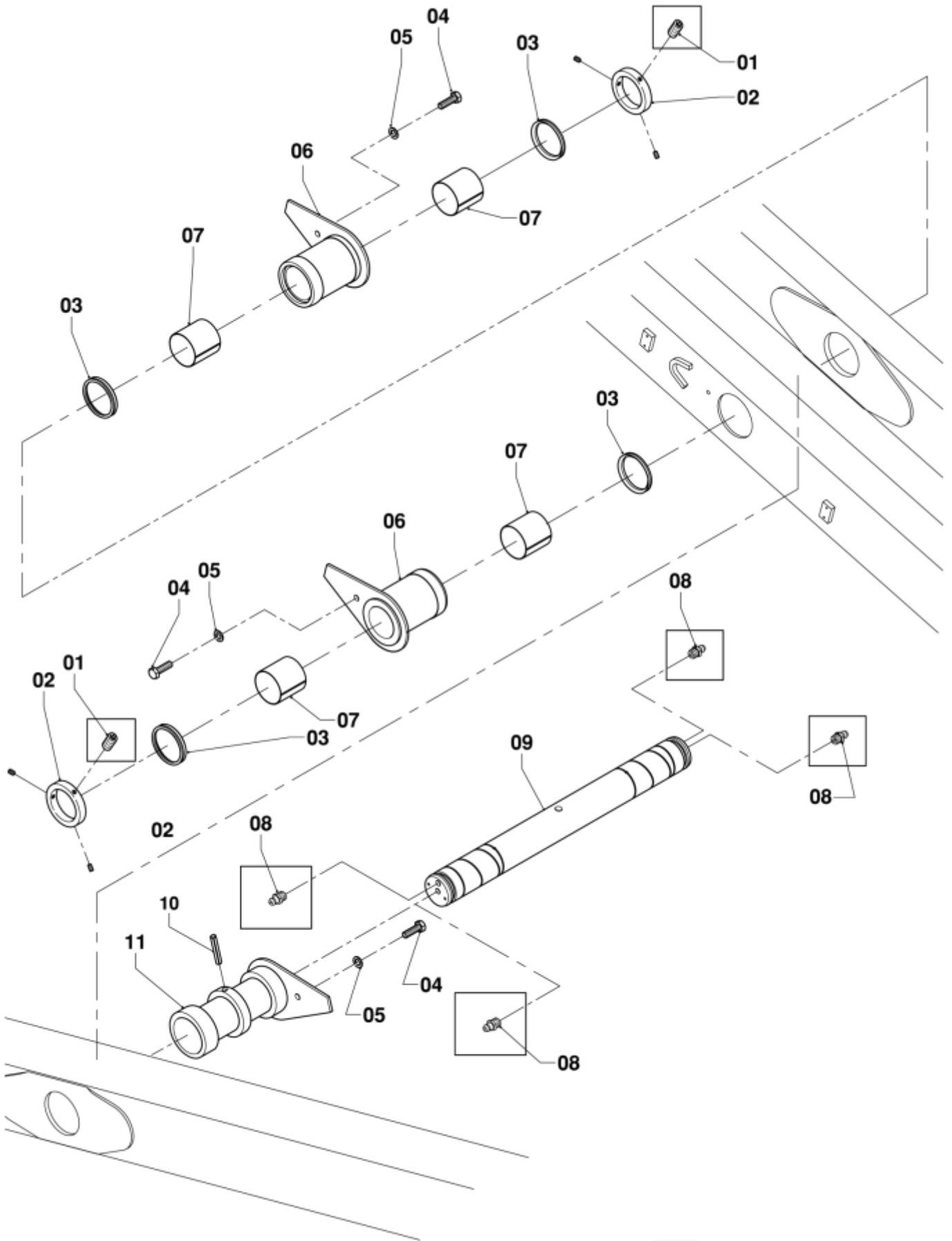

Item	Qty	Part number	Description
1	6	07840.100.020	Screw, DIN 916
2	1	RING60	Retaining ring
3	4	AFDICHT65A	Seal
4	3	01210.120.020	Bolt, DIN 933
5	3	38130.120.001	Washer, DIN 125-A
6	2	V120-01-42-4	Bush (outer / 20)
7	4	FLAGER156	Bearing Ø 60 / L = 60
8	4	NIPPELM8x1,25	Grease nipple
9	1	V120-01-42-3	Pin Ø 60 x 582
10	1	STIFT18 x80	Spring type straight pin
11	1	V120-01-42-2	Bush (inner / 20)

### Joint 20-B

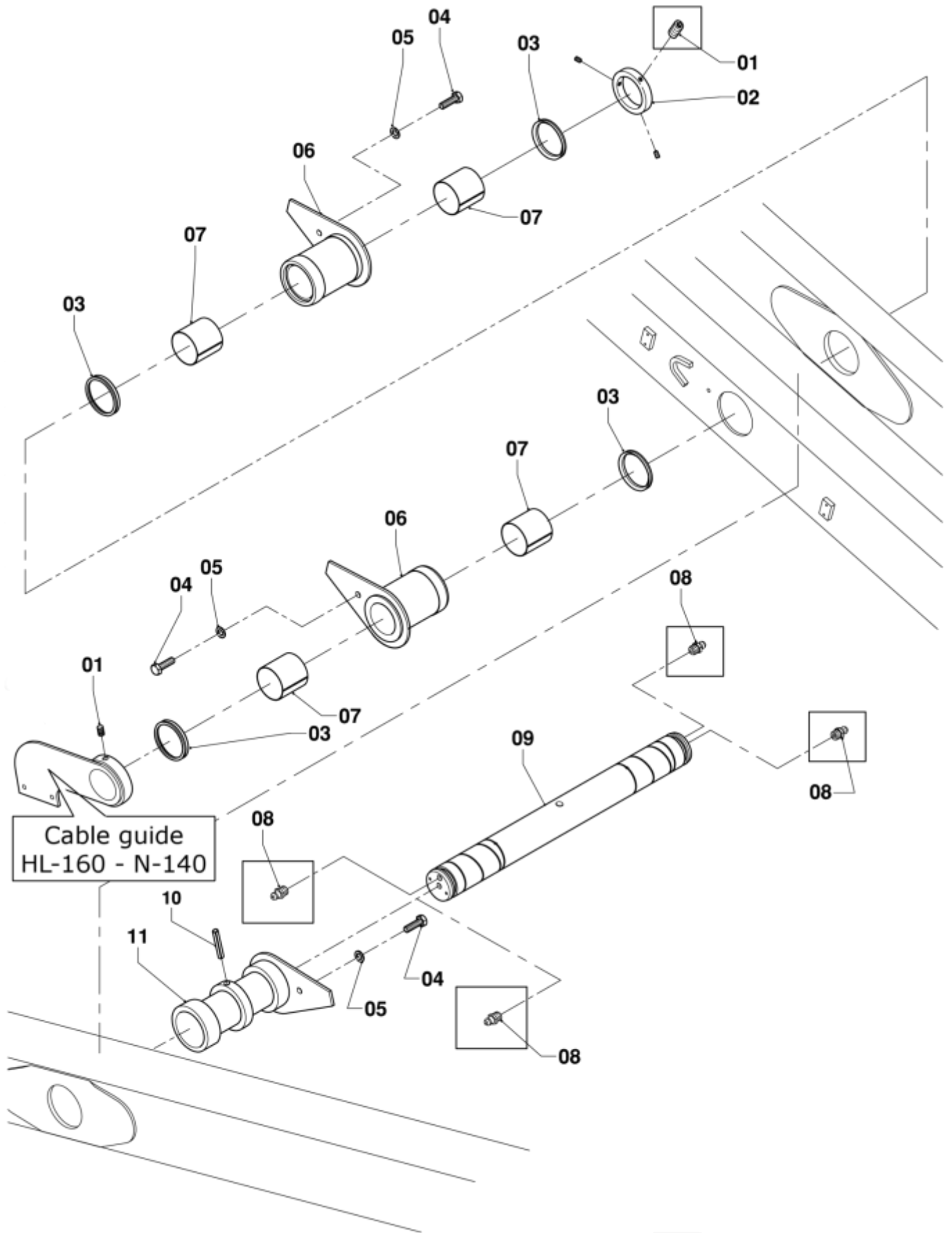

Item	Qty	Part number	Description
1	6	07840.100.020	Screw, DIN 916
2	1	RING60	Retaining ring
3	4	AFDICHT65A	Seal
4	3	01210.120.020	Bolt, DIN 933
5	3	38130.120.001	Washer, DIN 125-A
6	2	V140-01-42-1	Bush (outer / 20)
7	4	FLAGER156	BearingØ 60 / L = 60
8	4	NIPPELM8x1,25	Grease nipple
9	1	V140-01-42-3	Pin Ø 60 x 582
10	1	STIFT18 x80	Spring type straight pin
11	1	V140-01-42-2	Bush (inner / 20)

### Joint 20-C

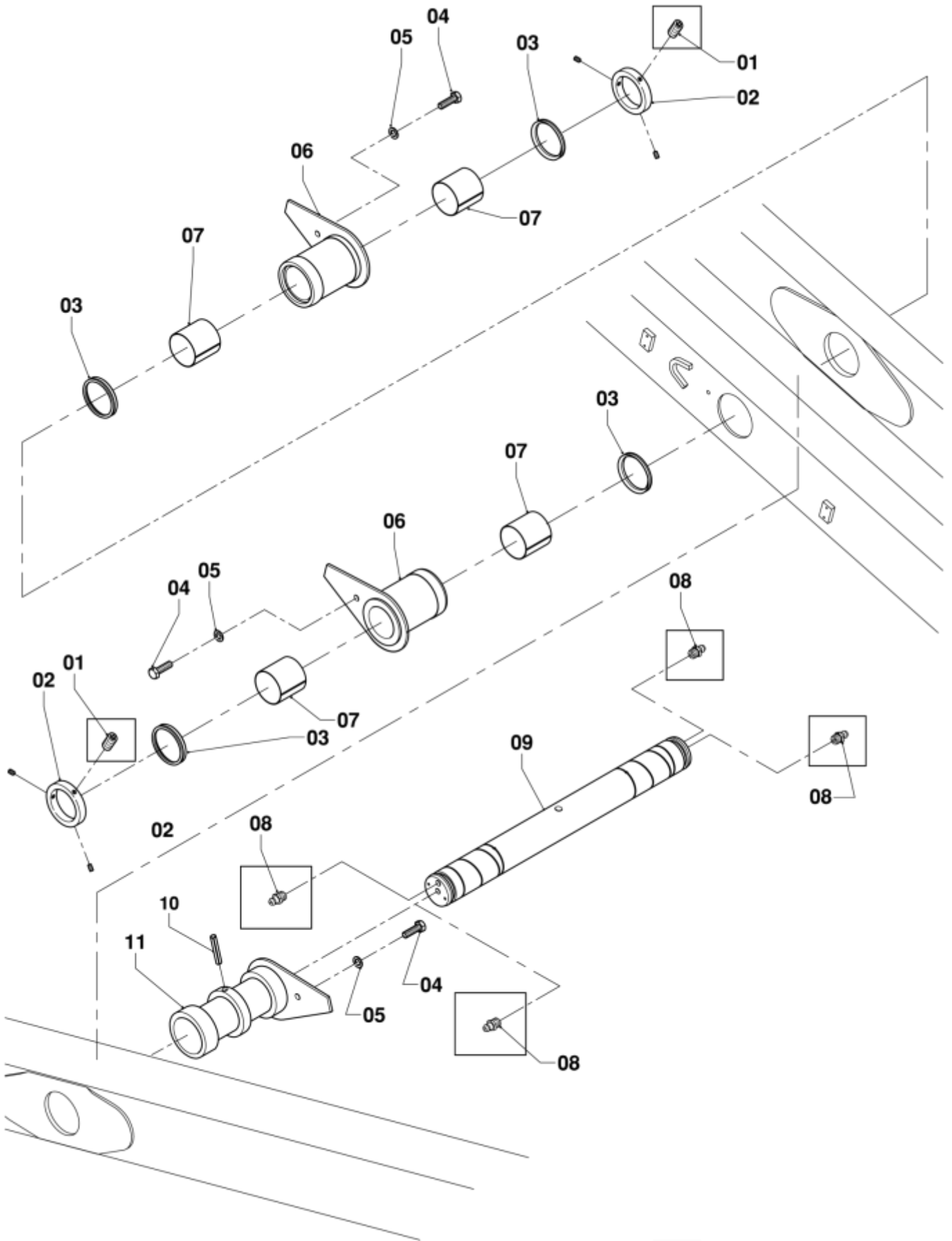

Item	Qty	Part number	Description
1	6	07840.100.020	Screw, DIN 916
2	1	RING60	Retaining ring
3	4	AFDICHT65A	Seal
4	3	01210.120.020	Bolt, DIN 933
5	3	38130.120.001	Washer, DIN 125-A
6	2	V165-01-42-1	Bush (outer / 20)
7	4	FLAGER156	Bearing Ø 60 / L = 60
8	4	NIPPELM8x1,25	Grease nipple
9	1	V165-01-42-3	Pin Ø 60 x 582
10	1	STIFT18 x80	Spring type straight pin
11	1	V165-01-42-2	Bush (inner / 20)

### Joint 13

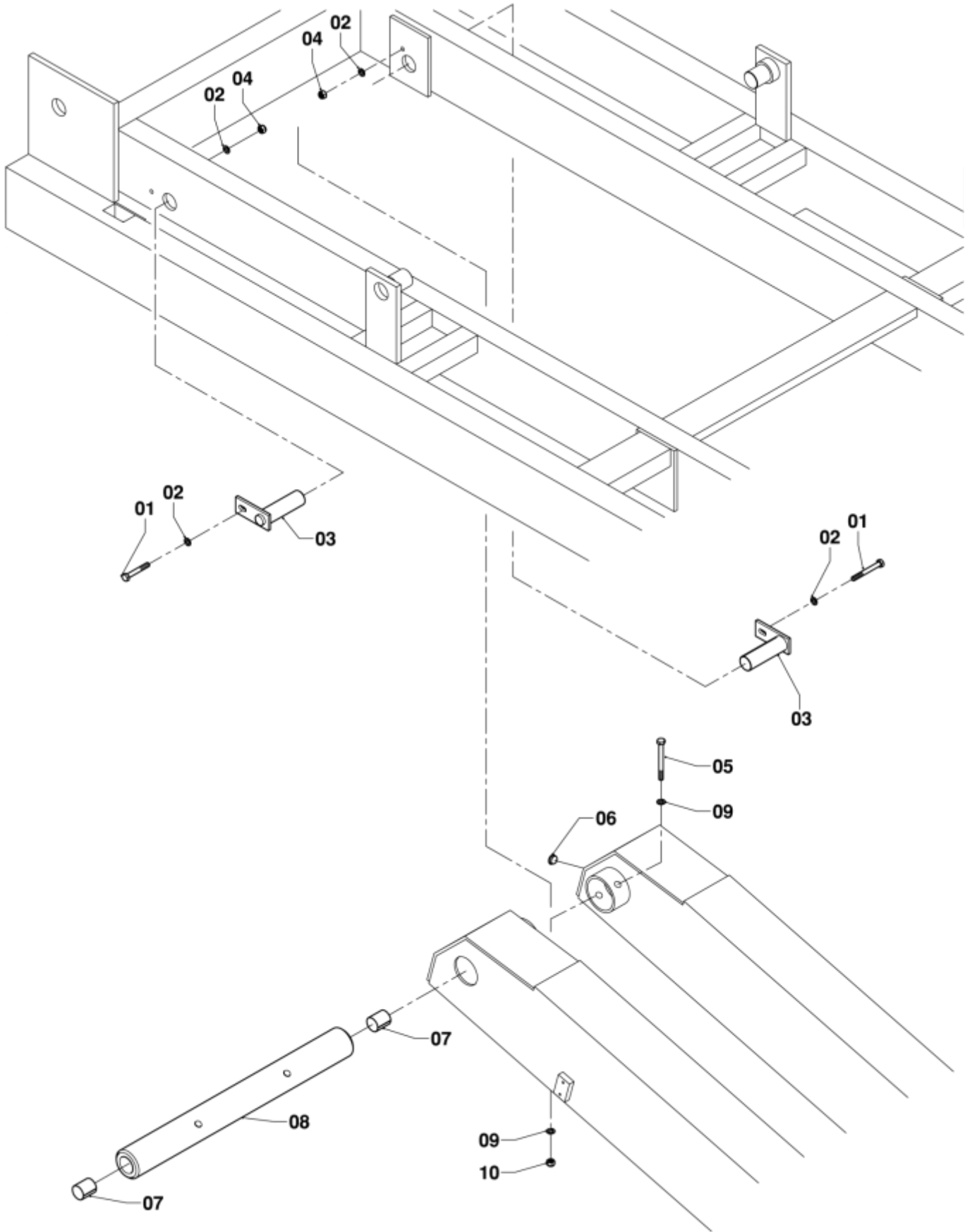



Item	Qty	Part number	Description
1	2	01200.080.020	Bolt, DIN 931
2	4	38130.080.001	Washer, DIN 125-A
3	2	V-01-36-1	Pin Ø 30 x 107
4	2	12300.080.001	Nut, DIN 985
5	2	01200.100.090	Bolt, DIN 931
6	4	STOP022	Plug
7	2	FLAGER066	Bearing Ø 30 / L = 40
8	1	V-01-36-2	Pin Ø 60 x 572
9	4	38130.100.001	Washer, DIN 125-A
10	2	12300.100.001	Nut, DIN 985

### Joint 14

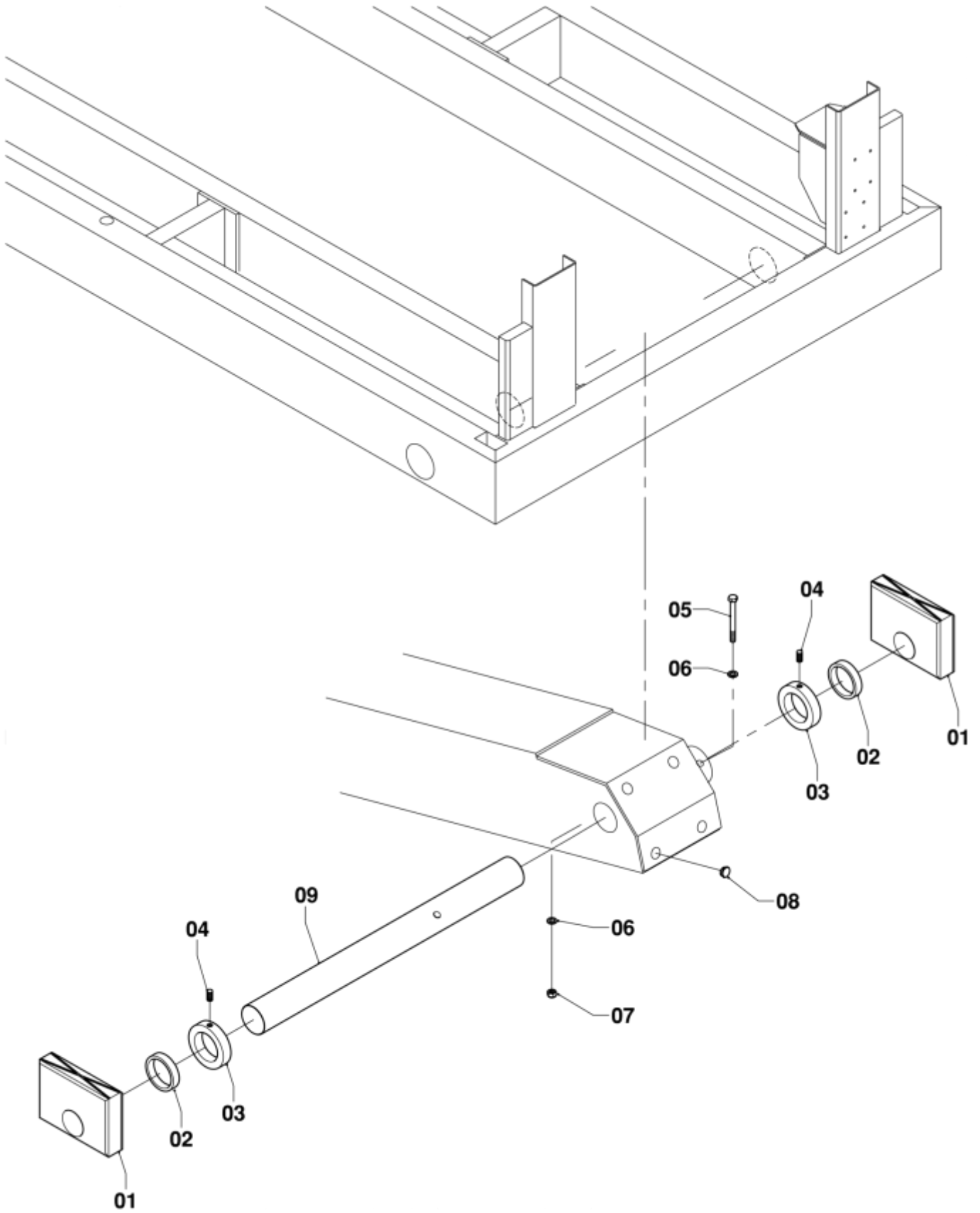

Item	Qty	Part number	Description
1	2	V-01-36-3	Sliding block (GLYBLOK067)
2	2	V-01-36-4	Spacer
3	2	RING60	Retaining ring
4	2	07840.100.025	Screw, DIN 916
5	1	01200.100.090	Bolt, DIN 931
6	2	38130.100.001	Washer, DIN 125-A
7	1	12300.100.001	Nut, DIN 985
8	4	STOP022	Plug
9	1	V-01-36-5	As Ø 60 x 676

### Cable guide HL-140 - N-120

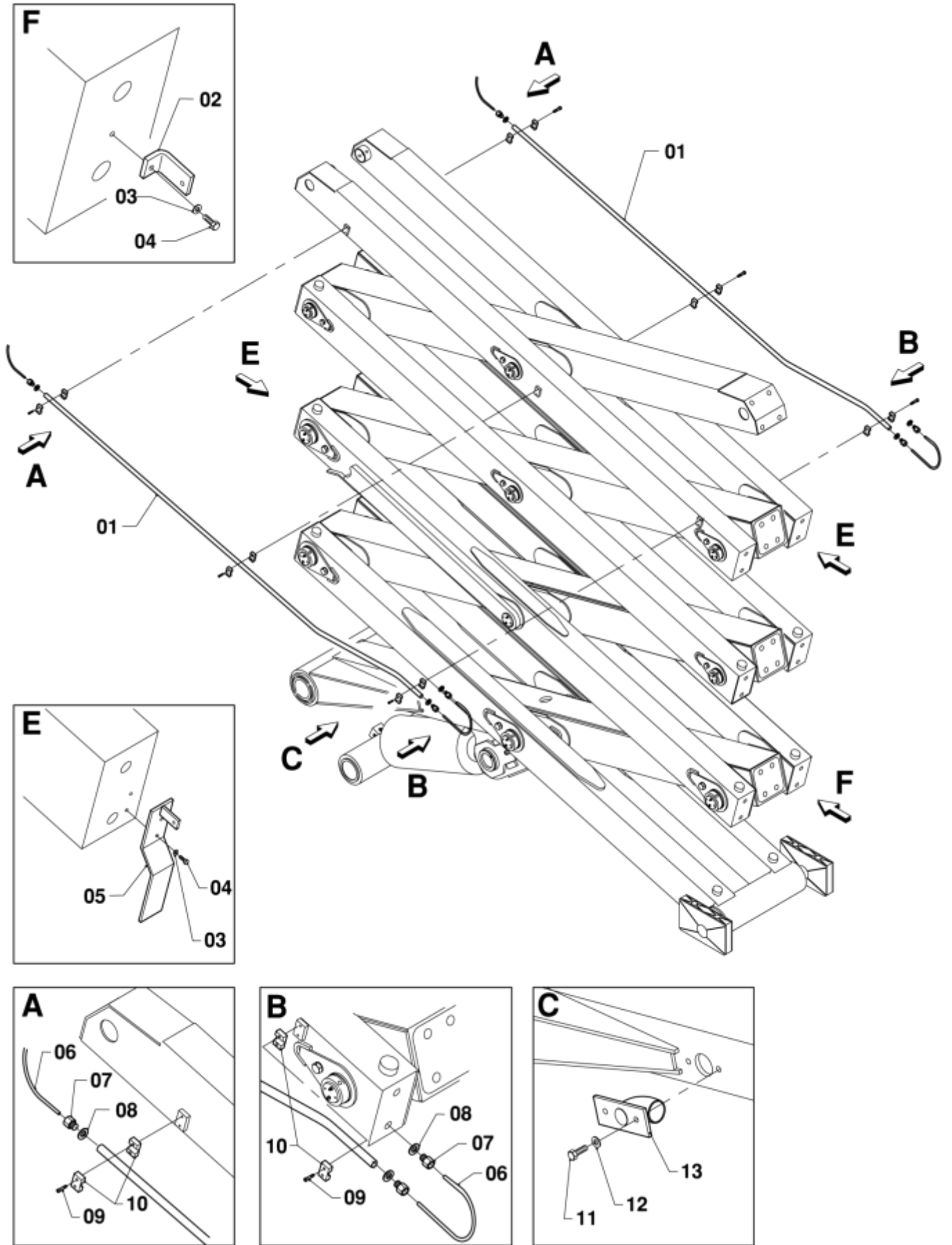

Item	Qty	Part number	Description
1	2	V120-01-69-1	Cable guide
2	2	V120-01-69-2	Cable bracket
3	10	38130.050.001	Washer, DIN 125-A
4	10	07840.050.020	Bolt, DIN 916
5	4	V120-01-69-3	Cable bracket
6	-	- - - -	Cable
7	-	WARTEL 13.5 K	Cable gland
8	-	ADAPTOR 02	Adapter
9	8	01210.060.050	Bolt, DIN 933
10	12	LEIDB025	Pipe bracket
11	4	01210.100.025	Bolt, DIN 933
12	4	38130.100.001	Washer, DIN 125-A
13	2	V120-01-69-4	Cable entrance

### Cable guide HL-160 - N-140

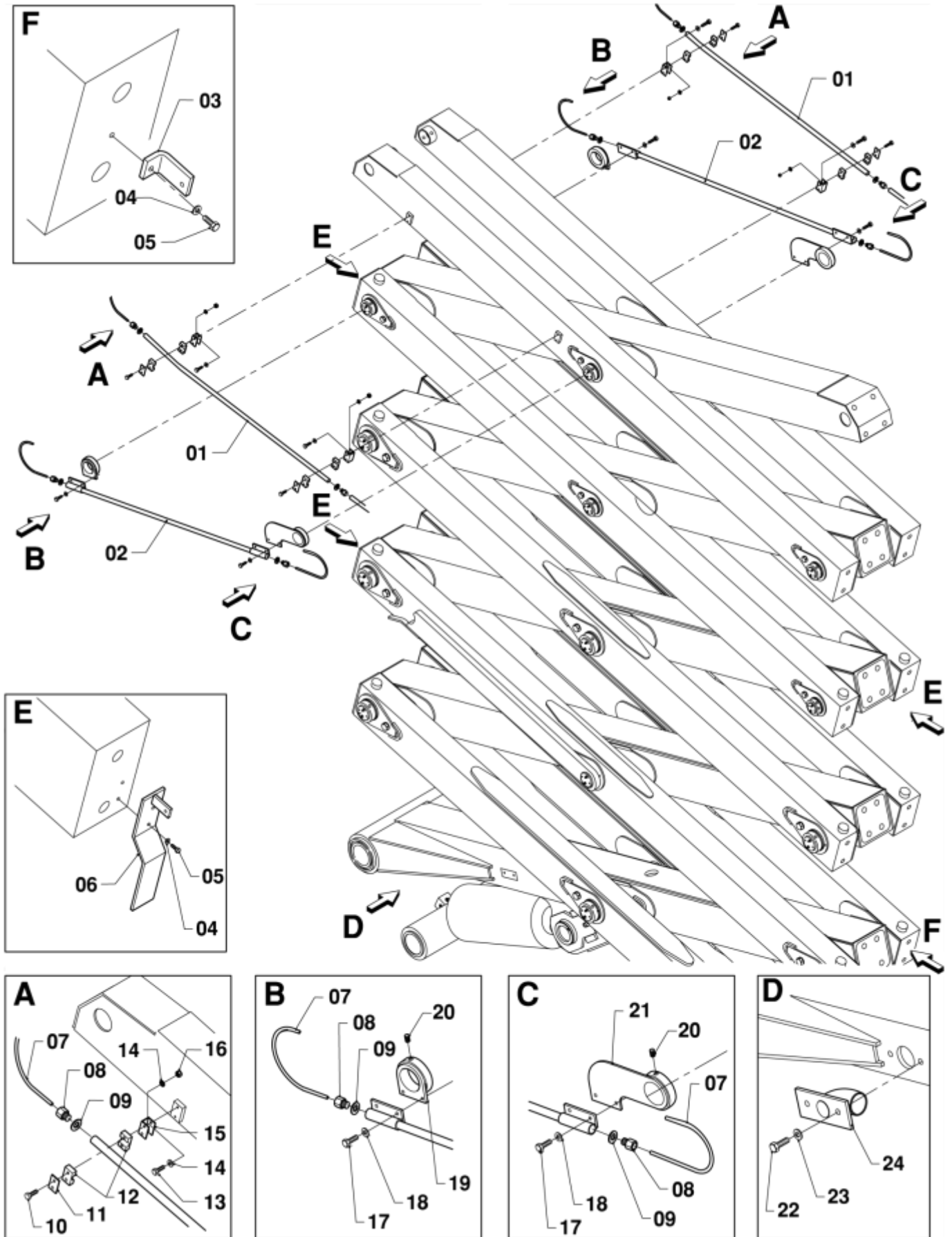

Item	Qty	Part number	Description
1	2	V140-01-69-1	Cable guide
2	2	V140-01-69-2	Cable guide
3	2	V140-01-69-3	Cable bracket
4	14	38130.050.001	Washer, DIN 125-A
5	14	07840.050.020	Bolt, DIN 916
6	6	V140-01-69-4	Cable bracket
7	-	- - - -	Cable
8	-	WARTEL 13.5 K	Cable gland
9	-	ADAPTOR 02	Adapter
10	8	01210.060.050	Bolt, DIN 933
11	4	LEIDB.PL	Cover plate
12	8	LEIDB025	Pipe bracket
13	8	01210.060.012	Bolt, DIN 933
14	16	38130.050.001	Washer, DIN 125-A
15	4	V140-01-69-5	U-Profile
16	8	01210.060.001	Nut, DIN 985
17	8	01210.080.016	Bolt, DIN 933
18	8	38130.080.001	Washer, DIN 125-A
19	2	V140-01-69-6	Retaining ring + plate
20	6	07840.100.020	Screw, DIN 916
21	2	V140-01-69-7	Retaining ring + plate
22	4	01210.100.025	Bolt, DIN 933
23	4	38130.100.001	Washer, DIN 125-A
24	2	V140-01-69-8	Cable entrance

### Cable guide HL-190 - N-165

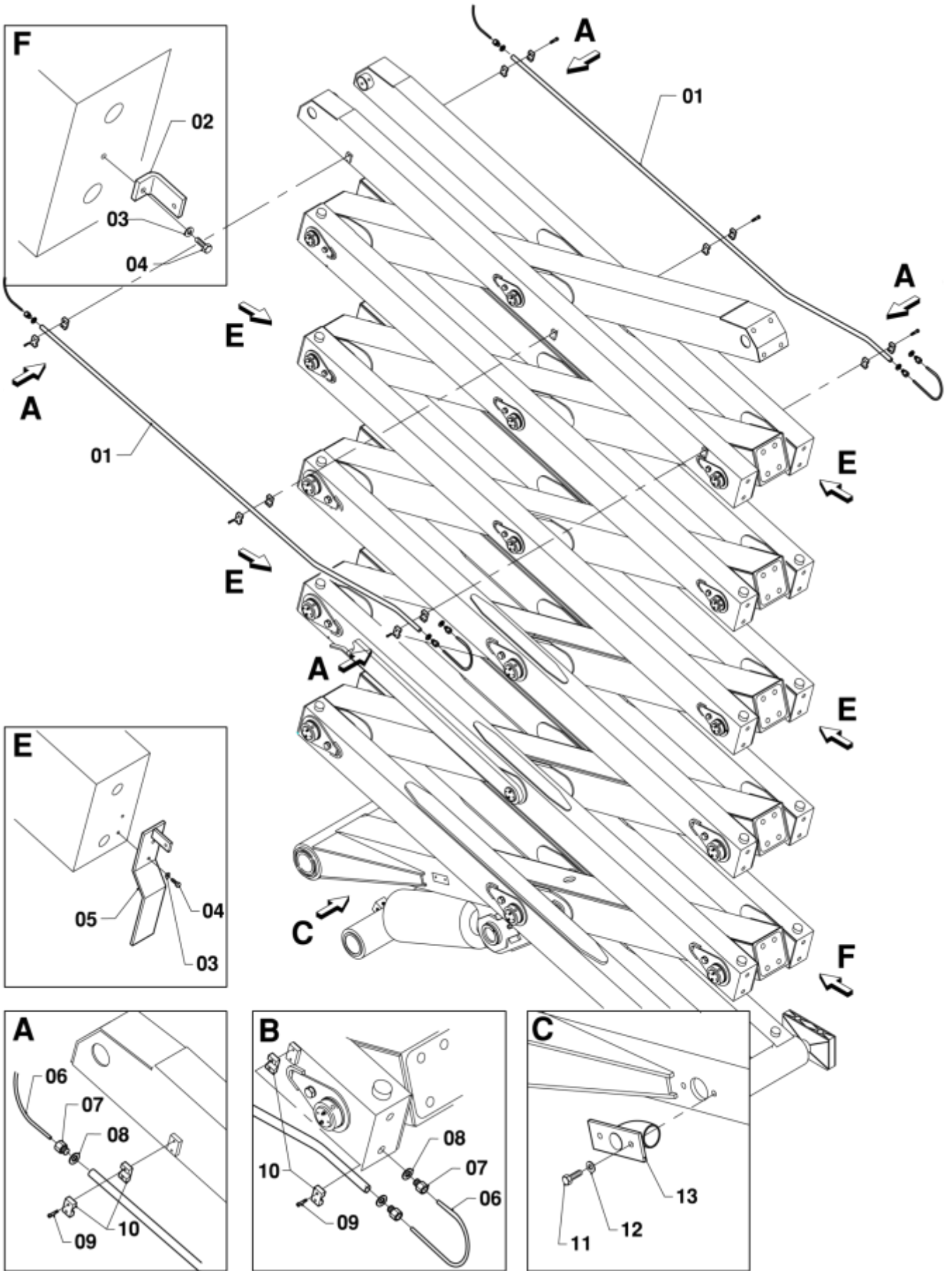



Item	Qty	Part number	Description
1	2	V165-01-69-1	Cable guide
2	2	V165-01-69-2	Cable bracket
3	18	38130.050.001	Washer, DIN 125-A
4	18	07840.050.020	Bolt, DIN 916
5	8	V165-01-69-3	Cable bracket
6	-	- - - -	Cable
7	-	WARTEL 13.5 K	Cable gland
8	-	ADAPTOR 02	Adapter
9	8	01210.060.050	Bolt, DIN 933
10	8	LEIDB025	Stauff bracket 25 mm
11	4	01210.100.025	Bolt, DIN 933
12	4	38130.100.001	Washer, DIN 125-A
13	2	V165-01-69-4	Cable entrance



# SECTION FRAME

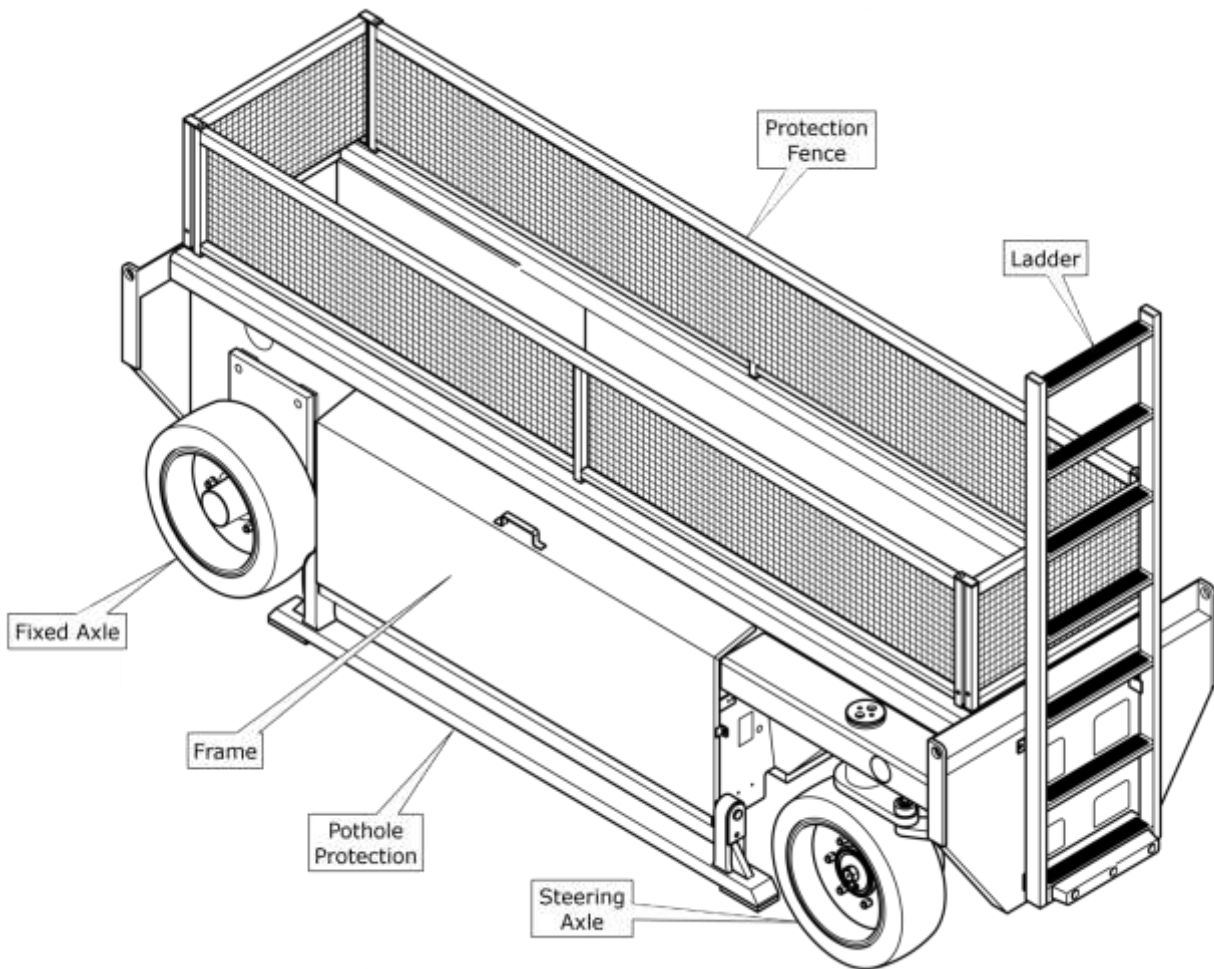

# Frame

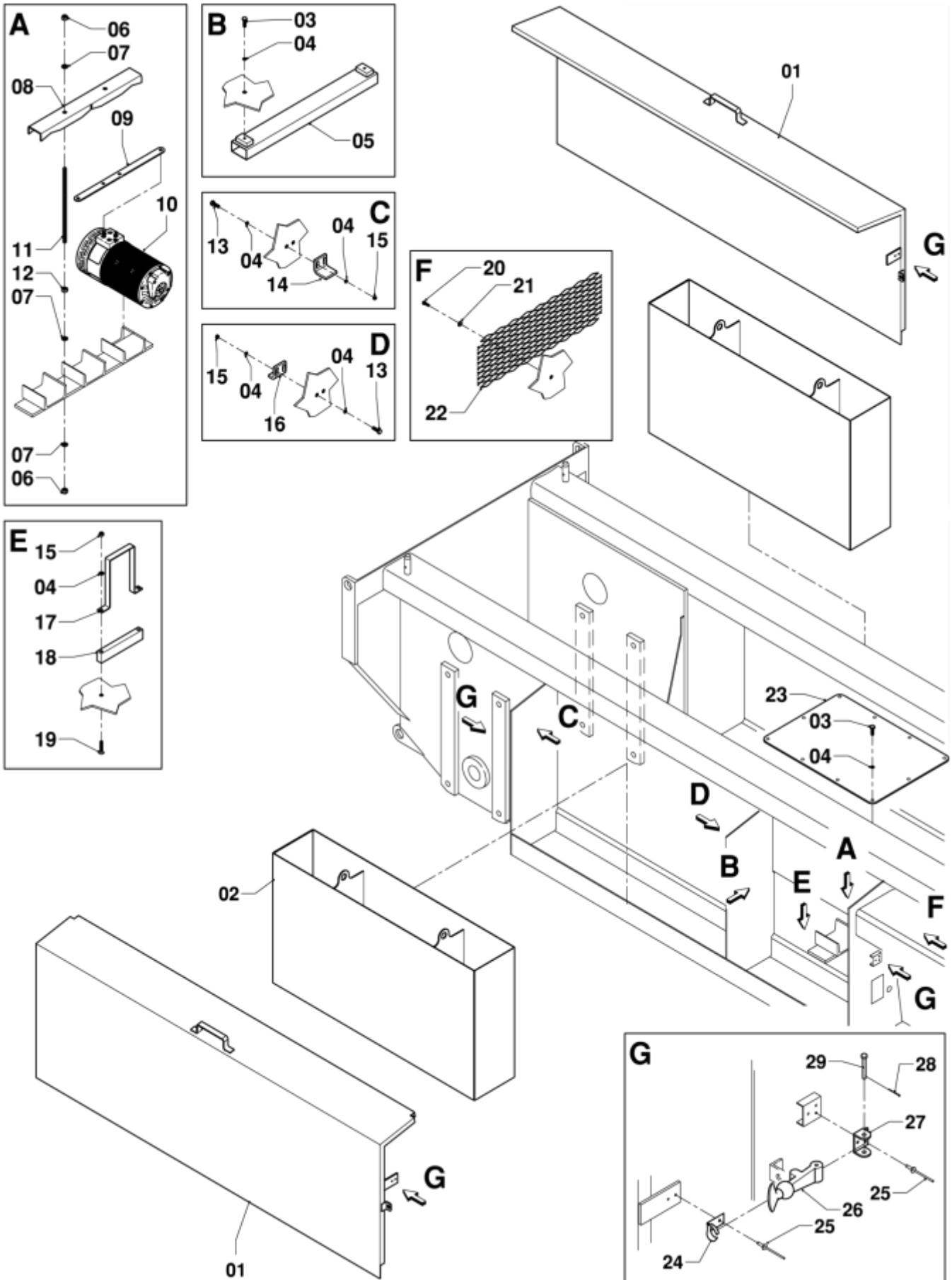

Item	Qty	Part number	Description
1	2	K-01-128	Cover
2	2	K-01-130	Battery container
3	12	01210.080.020	Bolt, DIN 933
4	28	38130.080.001	Washer, DIN 125-A
5	1	V-01-12-1	Cable guide
6	4	12300.100.001	Nut, DIN 985
7	6	38130.100.001	Washer, DIN 125-A
8	1	V-01-16-1	Motor bracket
9	1	- - - -	Copper strip
10	-	(See hydraulic plan)	Elektro-hydro pump
11	2	V-01-16-2	M10 / L= 250 / 8.8
12	2	01300.050.001	NUT, DIN 934
13	4	01210.080.030	Bolt, DIN 933
14	2	V-01-16-3	Locking strip
15	12	12300.080.001	Nut, DIN 985
16	2	V-01-16-4	Locking strip
17	2	V-01-16-5	Bracket
18	2	V-01-16-6	Block
19	4	07470.080.055	Bolt, DIN 7991
20	4	01210.060.020	Bolt, DIN 933
21	4	38130.060.001	Washer, DIN 125-A
22	1	V-01-18	Gauze
23	1	V-01-12-2	Plate
24	20	32200.040.010	4 x 10,5
25	4	SLUIT010	Fastening

# Steering axle

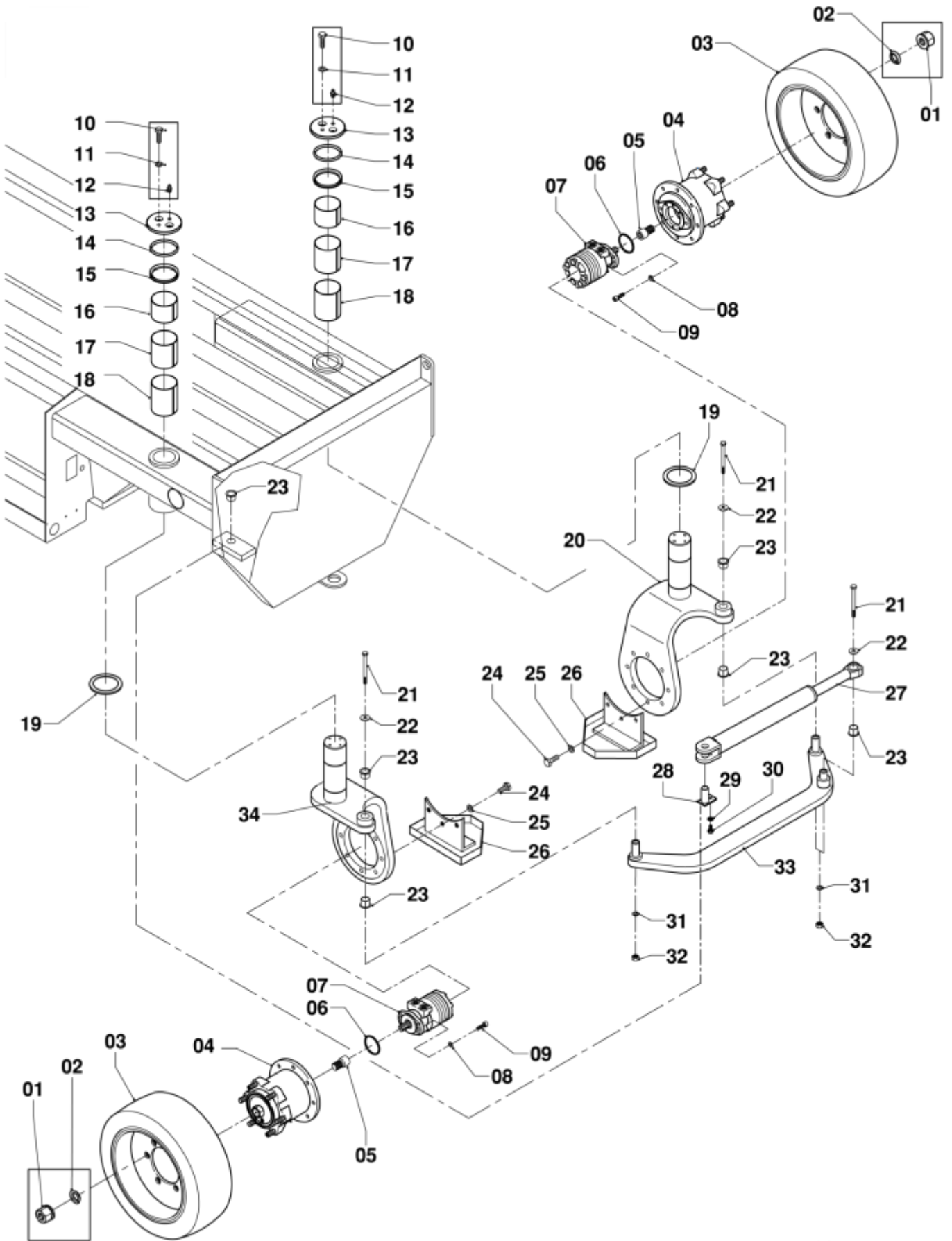

Item	Qty	Part number	Description
1	12	MOER190	Nut
2	2	R74361/M18	Washer, DIN 74361
3	2	W-01-50	Wheel (WIEL071NM)
4	2	WIELK050A	Drive hub
5	2	- - - -	Adapter
6	2	- - - -	O-ring 9,25 x 1,78
7	2	HMOTOR500	Hydromotor
8	4	38130.120.001	Washer, DIN 125-A
9	4	38734.120.030	Bolt, DIN 912 12.9
10	4	01210.100.025	Bolt, DIN 933
11	4	38130.100.001	Washer, DIN 125-A
12	4	NIPPELM8x1,25	Grease nipple
13	2	V12-01-37-1	Locking plate
14	2	- - - -	O-ring 75,8 x 2,62
15	2	AFDICHT110A	Seal
16	2	FLAGER200	Bearing Ø 90 / L = 40
17	2	FLAGER201	Bearing Ø 90 / L = 90
18	2	FLAGER211	Bearing Ø 90 / L = 100
19	2	V12-01-37-2	Bearing
20	1	V12-01-37-3	Wheel support, Left
21	3	01200.160.140	Bolt, DIN 931
22	3	38210.160.001	Washer, DIN 9021
23	5	FLAGER572	Bearing
24	16	01210.160.060	Bolt, DIN 933
25	16	04030.160.001	Washer
26	2	K-01-129	Drip tray
27	1	CIL150W	Steer cylinder
28	1	V12-01-35-1	Pin
29	1	38130.010.001	Washer, DIN 125-A
30	1	01210.010.020	Bolt, DIN 933
31	3	38130.160.001	Washer, DIN 125-A
32	3	12300.160.001	Nut, DIN 985
33	1	V12-01-35-2	Track rod
34	1	V12-01-37-4	Wheel support, Right

## Fixed Axle

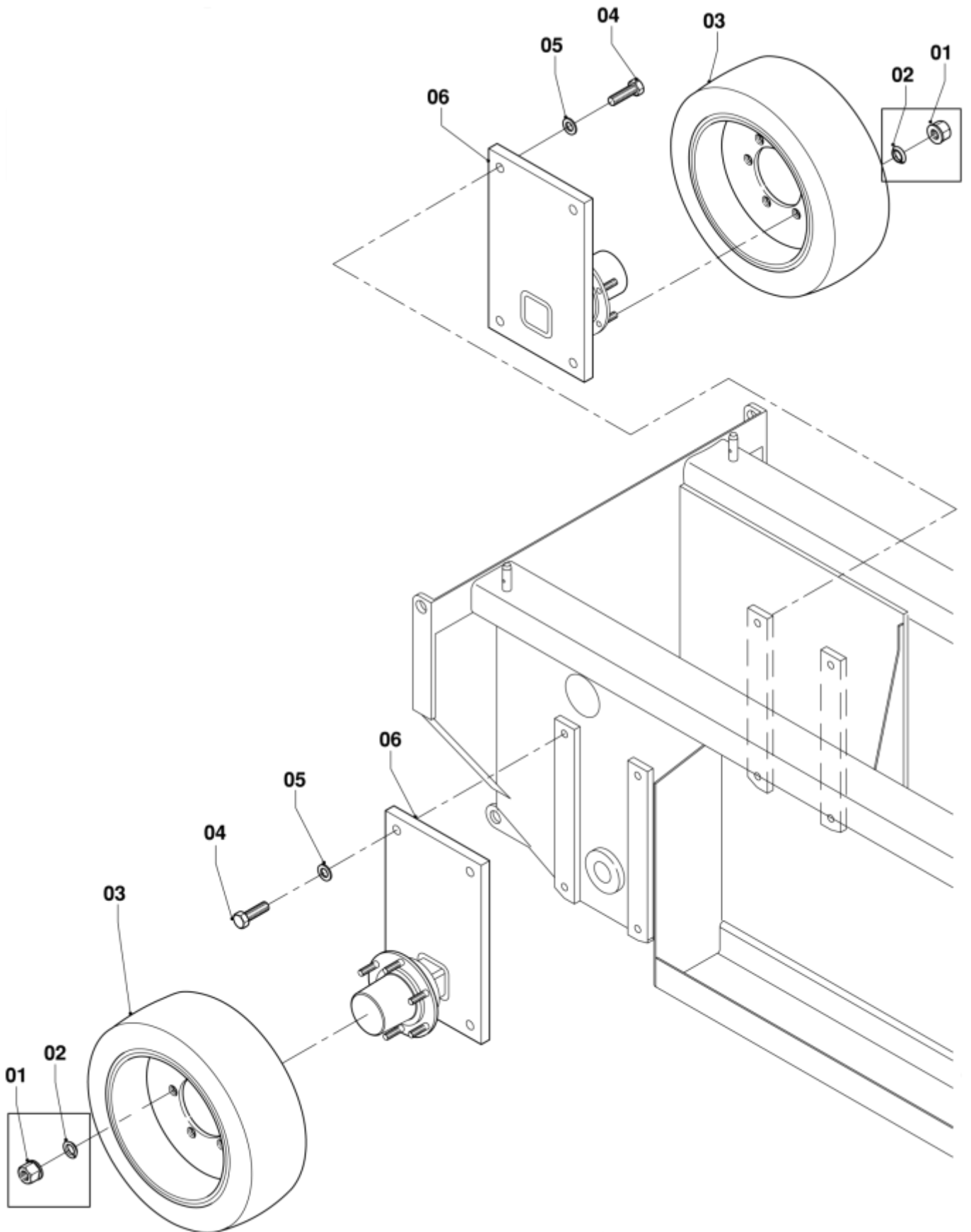



<b>Item</b>	<b>Qty</b>	<b>Part number</b>	<b>Description</b>
1	12	MOER190	Nut
2	12	R74361/M18	Washer, DIN 74361
3	2	W-01-50	Wheel (WIEL071NM)
4	8	01210.240.80	Bolt, DIN 933
5	8	04030.240.001	Washer
6	2	V12-01-40	Rear axle

### Pothole Protection 1-2

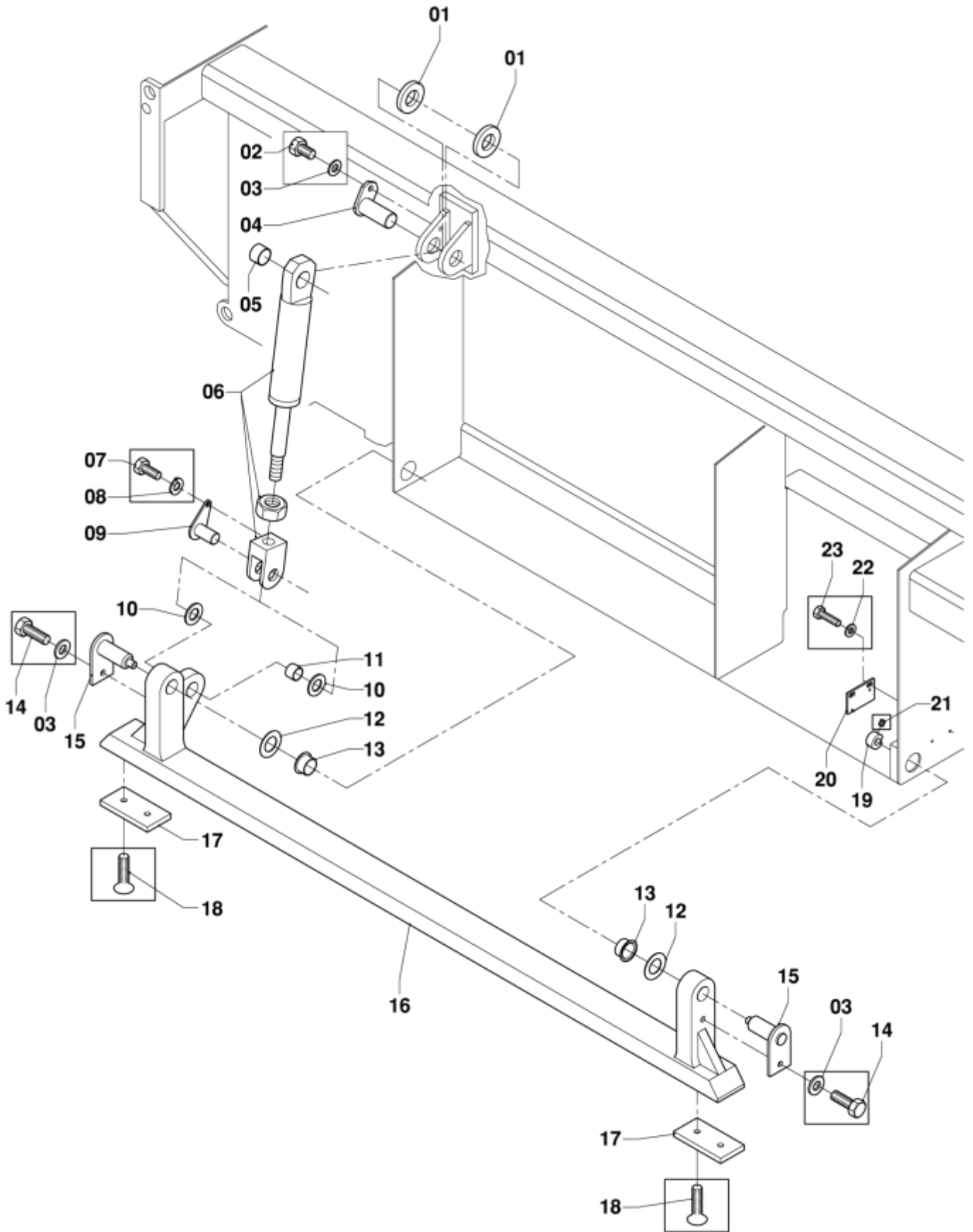

Item	Qty	Part number	Description
1	2	V-01-17-1	Washer
2	1	01210.120.020	Bolt, DIN 933
3	3	38130.120.001	Washer, DIN 125-A
4	1	V-01-17-2	Pin
5	1	FLAGER078	Bearing Ø 40 / L = 30
6	1	CIL040W	Pot hole cylinder
7	1	01210.100.025	Bolt, DIN 933
8	1	38130.100.001	Washer, DIN 125-A
9	1	V-01-17-3	Pin
10	4	V-01-17-4	Washer
11	1	FLAGER018	Bearing Ø 30 / L = 25
12	2	V-01-17-5	Washer
13	2	FLAGER578	Bearing Ø 45 / L = 30
14	2	01210.120.035	Bolt, DIN 933
15	2	V-01-17-6	Pin
16	1	V-01-17-7	Pot hole beam R
17	2	V-01-17-8	Plate
18	4	07470.120.025	Bolt, DIN 7991
19	1	V-01-17-9	Cam disc
20	1	V-01-17-10	Plate
21	1	07840.060.008	Bolt, DIN 916
22	2	38130.080.001	Washer, DIN 125-A
23	2	01210.080.030	Bolt, DIN 933

### Pothole Protection 2-2

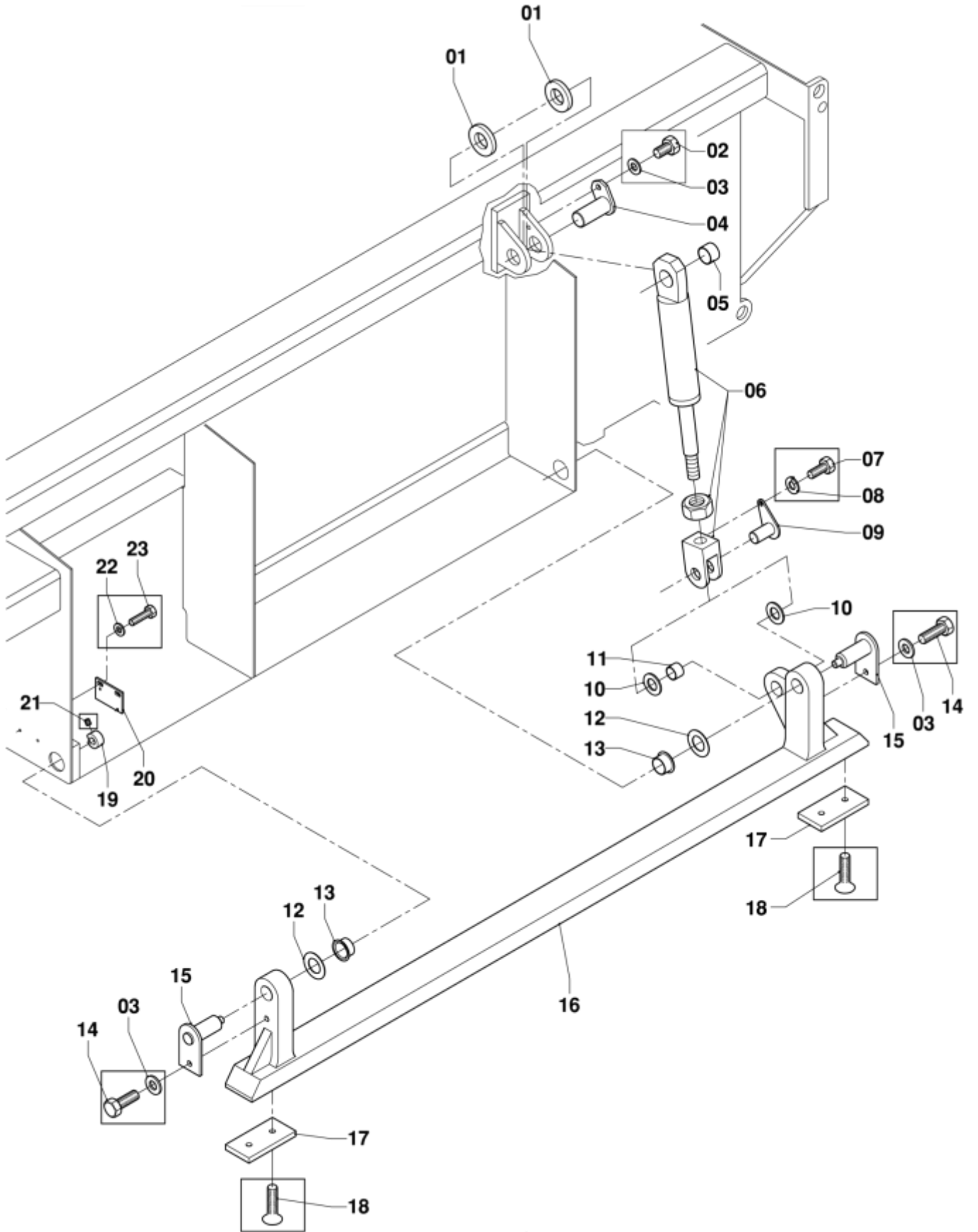

Item	Qty	Part number	Description
1	2	V-01-17-1	Washer
2	1	01210.120.020	Bolt, DIN 933
3	3	38130.120.001	Washer, DIN 125-A
4	1	V-01-17-2	Pin
5	1	FLAGER078	Bearing Ø 40 / L = 30
6	1	CIL040W	Pot hole cylinder
7	1	01210.100.025	Bolt, DIN 933
8	1	38130.100.001	Washer, DIN 125-A
9	1	V-01-17-3	Pin
10	4	V-01-17-4	Washer
11	1	FLAGER018	Bearing Ø 30 / L = 25
12	2	V-01-17-5	Washer
13	2	FLAGER578	Bearing Ø 45 / L = 30
14	2	01210.120.035	Bolt, DIN 933
15	2	V-01-17-6	Pin
16	1	V-01-17-11	Pot hole beam L
17	2	V-01-17-8	Plate
18	4	07470.120.025	Bolt, DIN 7991
19	1	V-01-17-9	Cam disc
20	1	V-01-17-10	Plate
21	1	07840.060.008	Bolt, DIN 916
22	2	38130.080.001	Washer, DIN 125-A
23	2	01210.080.030	Bolt, DIN 933

### Protection Fence 1-4

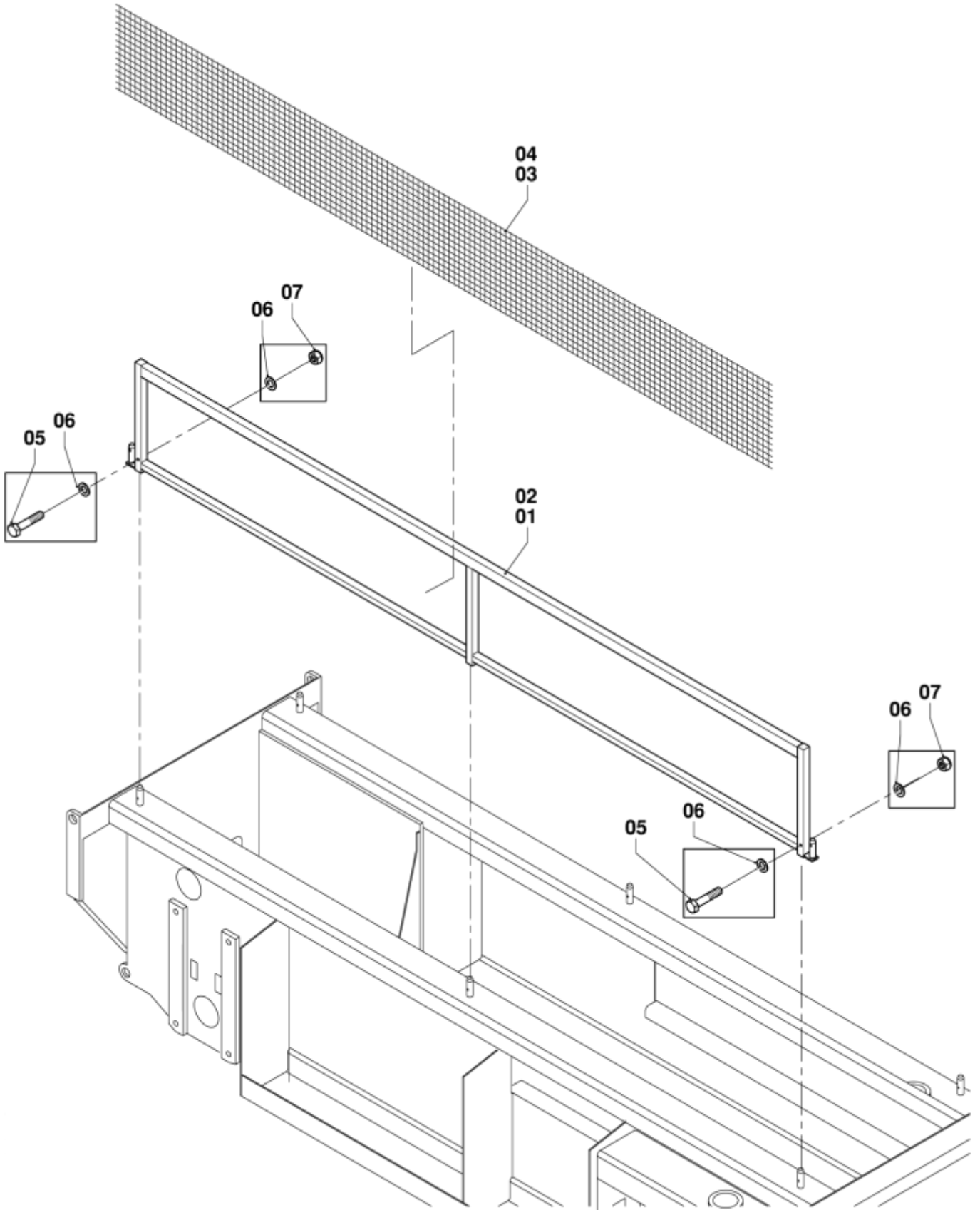

<b>Item</b>	<b>Qty</b>	<b>Part number</b>	<b>Description</b>
1	1	V-01-61-1	Protection fence (HL-160-190 E12 - N-140-165EL12)
2	1	V120-01-61-1	Protection fence (HL-140 E12 - N-120EL12)
3	-	GAAS 100	Gauze (HL-160-190 E12 - N-140-165EL12)
4	-	GAAS 100	Gauze (HL-140 E12 - N-120EL12)
5	2	01200.080.045	Bolt, DIN 931
6	4	38130.080.001	Washer, DIN 125-A
7	2	12300.080.001	Nut, DIN 985

### Protection Fence 2-4

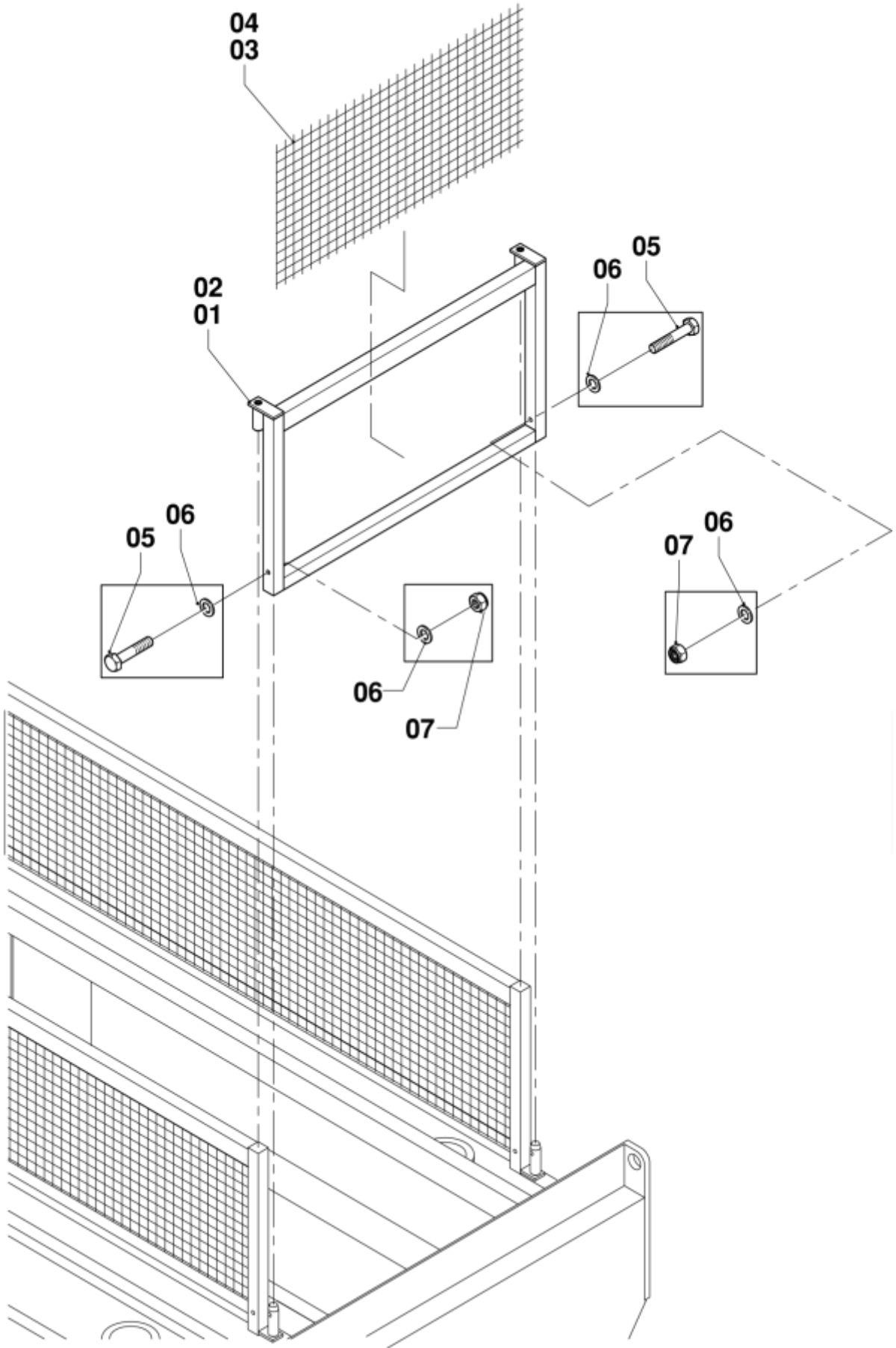



<b>Item</b>	<b>Qty</b>	<b>Part number</b>	<b>Description</b>
1	1	V-01-61-2	Protection fence (HL-160-190 E12 - N-140-165EL12)
2	1	V120-01-61-2	Protection fence (HL-140 E12 - N-120EL12)
3	-	GAAS 100	Gauze (HL-160-190 E12 - N-140-165EL12)
4	-	GAAS 100	Gauze (HL-140 E12 - N-120EL12)
5	2	01200.080.045	Bolt, DIN 931
6	4	38130.080.001	Washer, DIN 125-A
7	2	12300.080.001	Nut, DIN 985

### Protection Fence 3-4

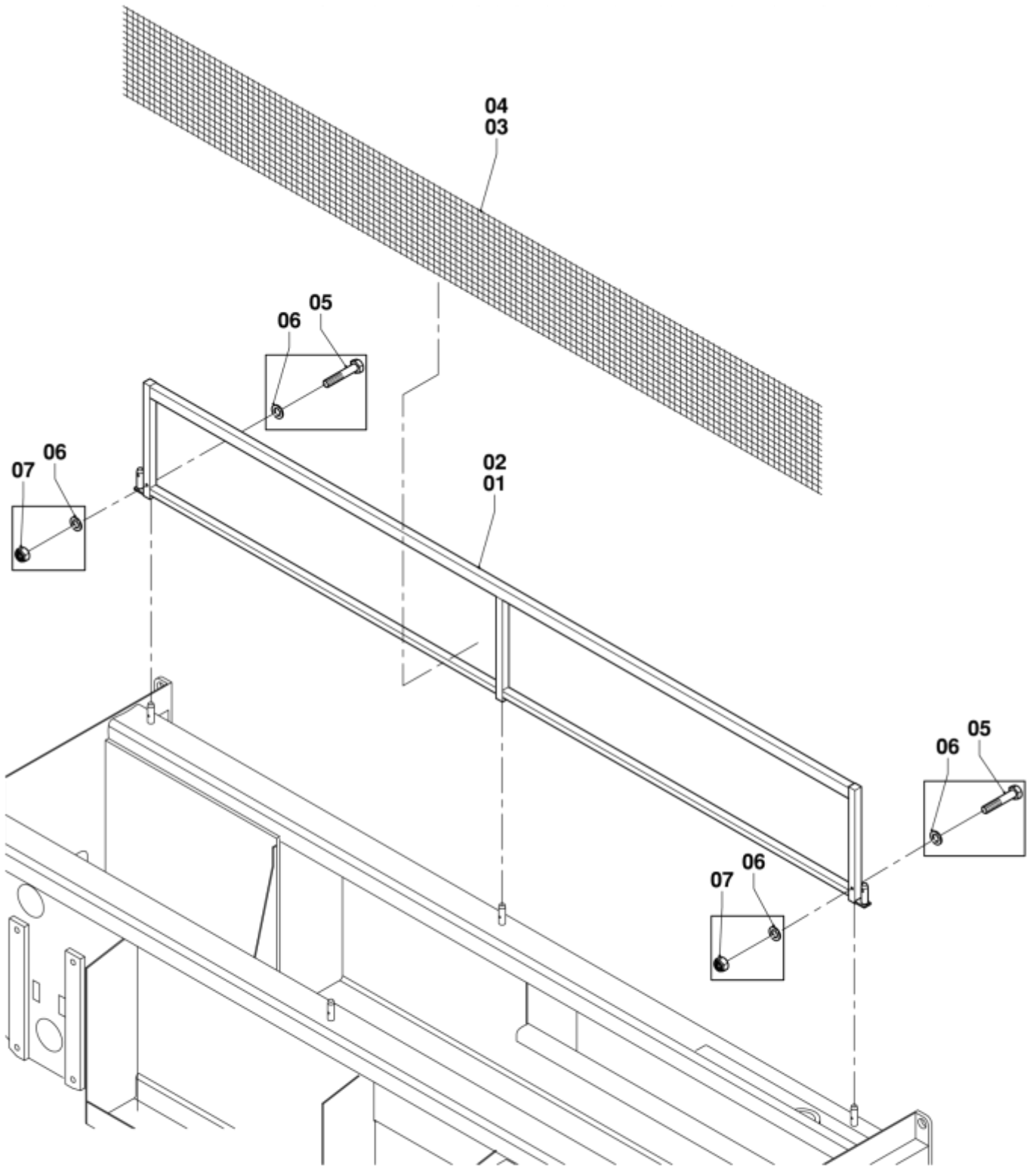

Item	Qty	Part number	Description
1	1	V-01-61-1	Protection fence (HL-160-190 E12 - N-140-165EL12)
2	1	V120-01-61-1	Protection fence (HL-140 E12 - N-120EL12)
3	-	GAAS 100	Gauze (HL-160-190 E12 - N-140-165EL12)
4	-	GAAS 100	Gauze (HL-140 E12 - N-120EL12)
5	2	01200.080.045	Bolt, DIN 931
6	4	38130.080.001	Washer, DIN 125-A
7	2	12300.080.001	Nut, DIN 985

Protection Fence 4-4

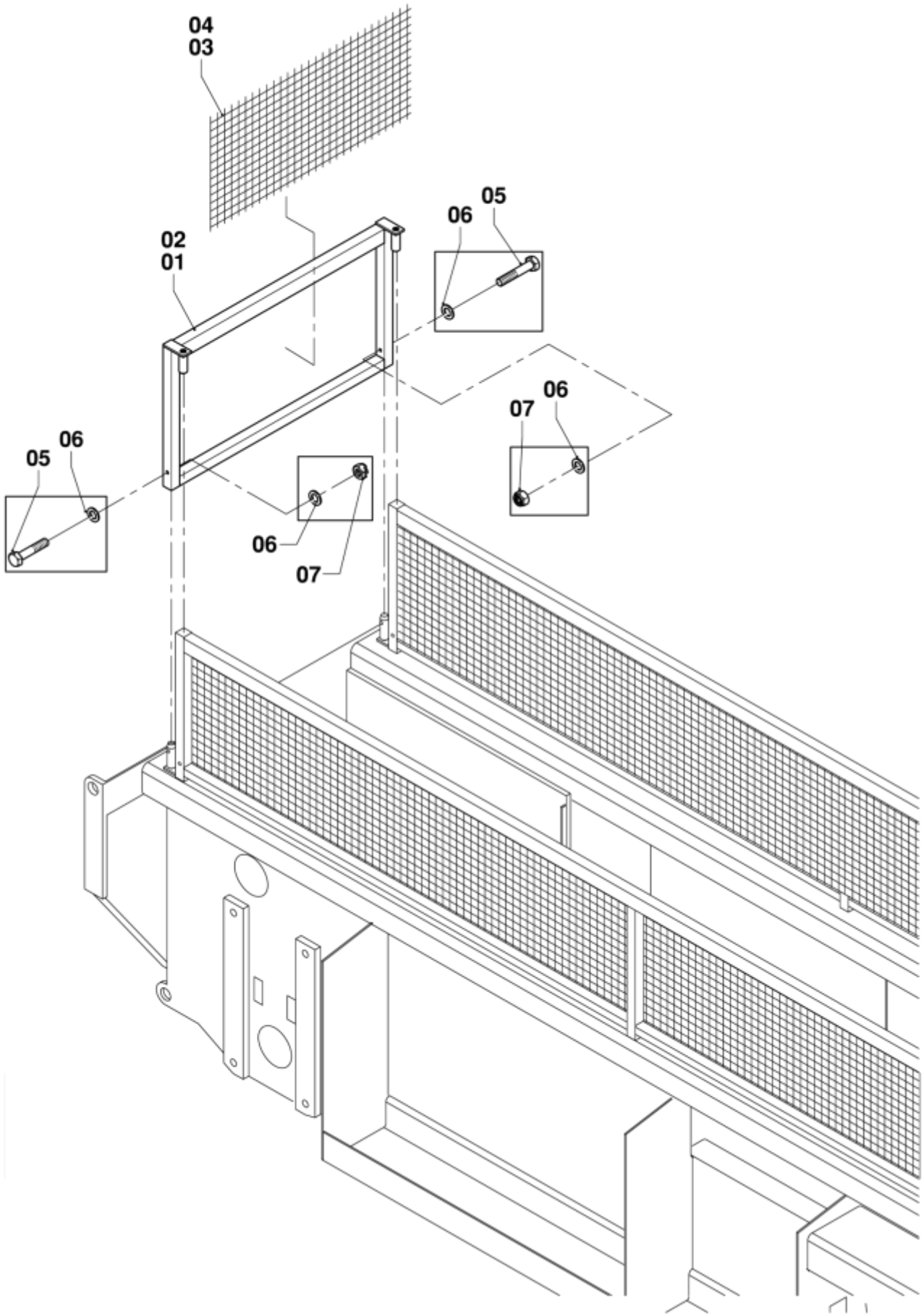

<b>Item</b>	<b>Qty</b>	<b>Part number</b>	<b>Description</b>
1	1	V-01-61-2	Protection fence (HL-160-190 E12 - N-140-165EL12)
2	1	V120-01-61-2	Protection fence (HL-140 E12 - N-120EL12)
3	-	GAAS 100	Gauze (HL-160-190 E12 - N-140-165EL12)
4	-	GAAS 100	Gauze (HL-140 E12 - N-120EL12)
5	2	01200.080.045	Bolt, DIN 931
6	4	38130.080.001	Washer, DIN 125-A
7	2	12300.080.001	Nut, DIN 985

# Ladder HL-140 - N-120

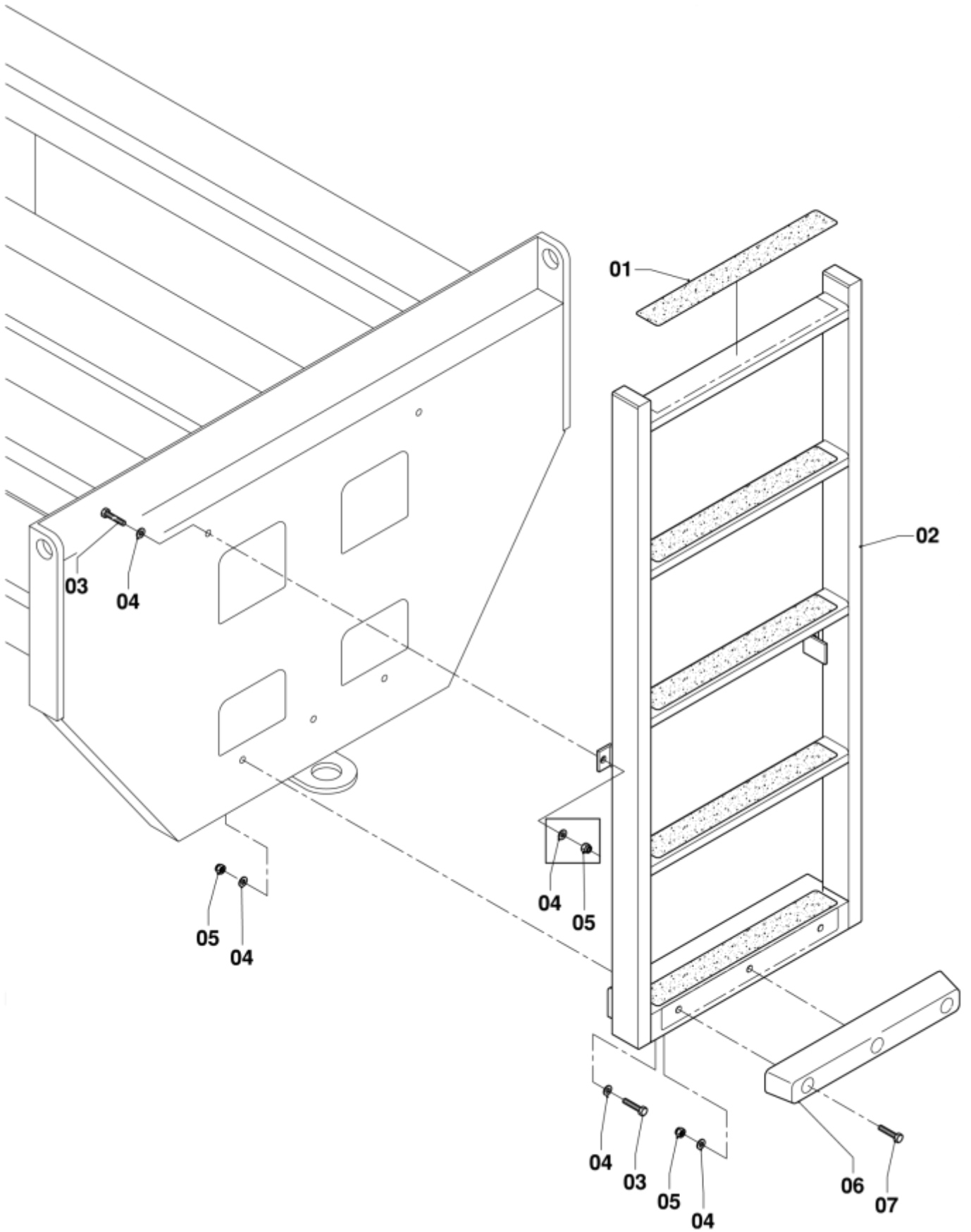

<b>Item</b>	<b>Qty</b>	<b>Part number</b>	<b>Description</b>
1	5	Band420X50	Slip-resistant strip
2	1	V120-01-65	Ladder
3	5	01210.100.30	Bolt, DIN 933
4	10	38130.100.001	Washer, DIN 125-A
5	11	12300.100.001	Nut, DIN 985
6	2	STOOTR10	Buffer
7	6	01200.100.45	Bolt, DIN 931

# Ladder HL-160 - N-140

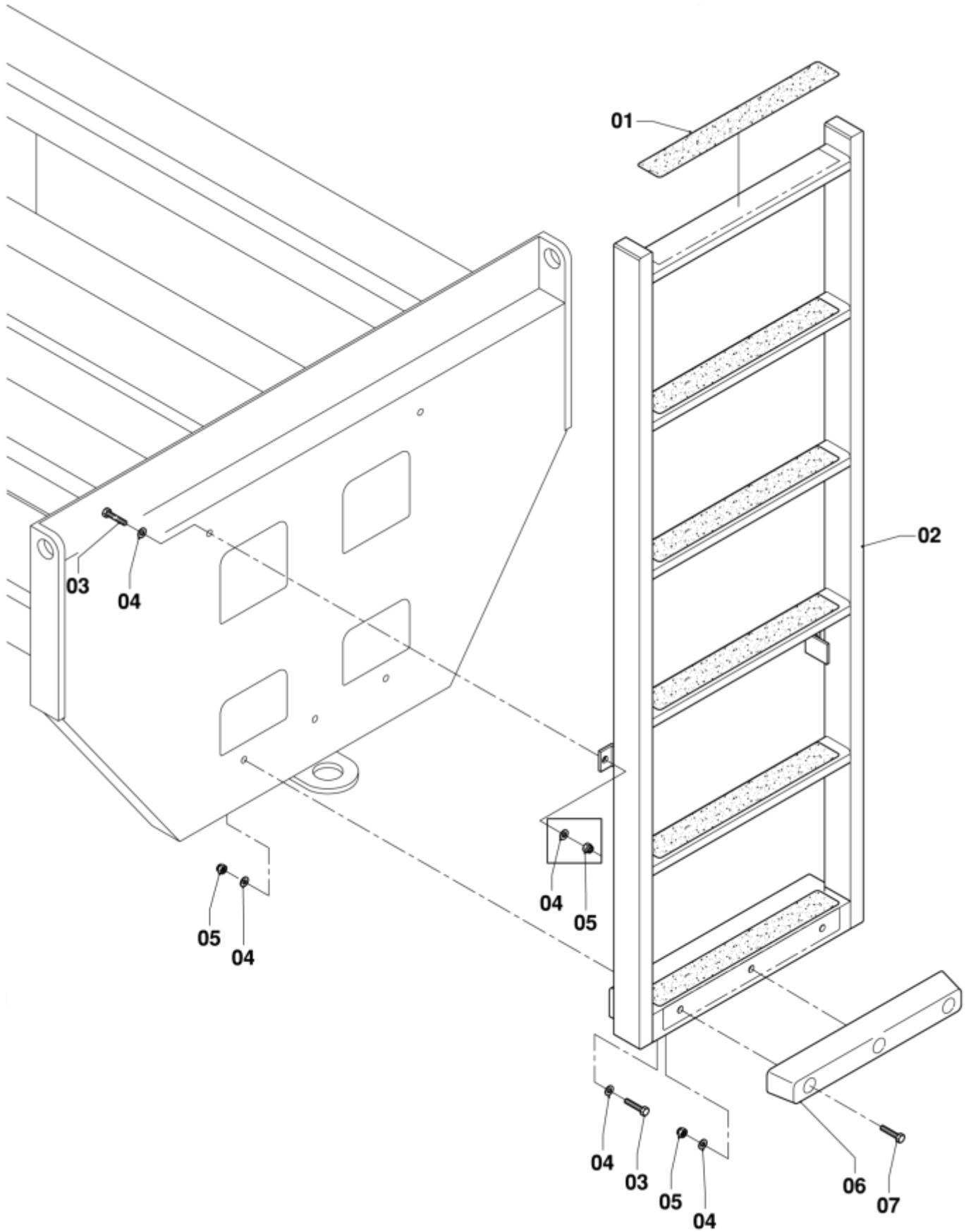



<b>Item</b>	<b>Qty</b>	<b>Part number</b>	<b>Description</b>
1	6	Band420X50	Slip-resistant strip
2	1	V140-01-65	Ladder
3	5	01210.100.30	Bolt, DIN 933
4	10	38130.100.001	Washer, DIN 125-A
5	11	12300.100.001	Nut, DIN 985
6	2	STOOTR10	Buffer
7	6	01200.100.45	Bolt, DIN 931

### Ladder HL-190 - N-165

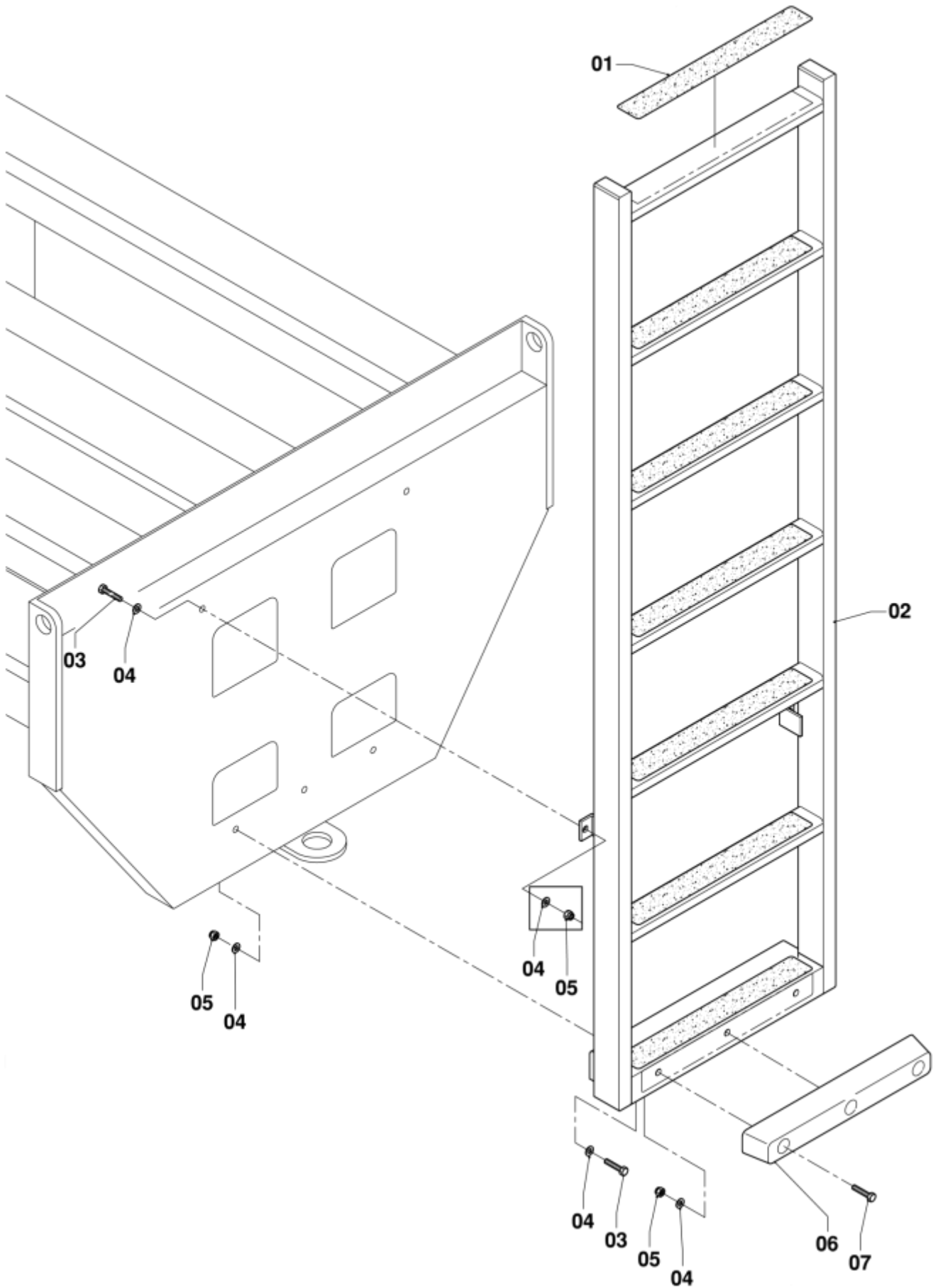

<b>Item</b>	<b>Qty</b>	<b>Part number</b>	<b>Description</b>
1	7	Band420X50	Slip-resistant strip
2	1	V165-01-65	Stair
3	5	01210.100.30	Bolt, DIN 933
4	10	38130.100.001	Washer, DIN 125-A
5	11	12300.100.001	Nut, DIN 985
6	2	STOOTR10	Buffer
7	6	01200.100.45	Bolt, DIN 931



# **SECTION CONTROL**

# Control Box

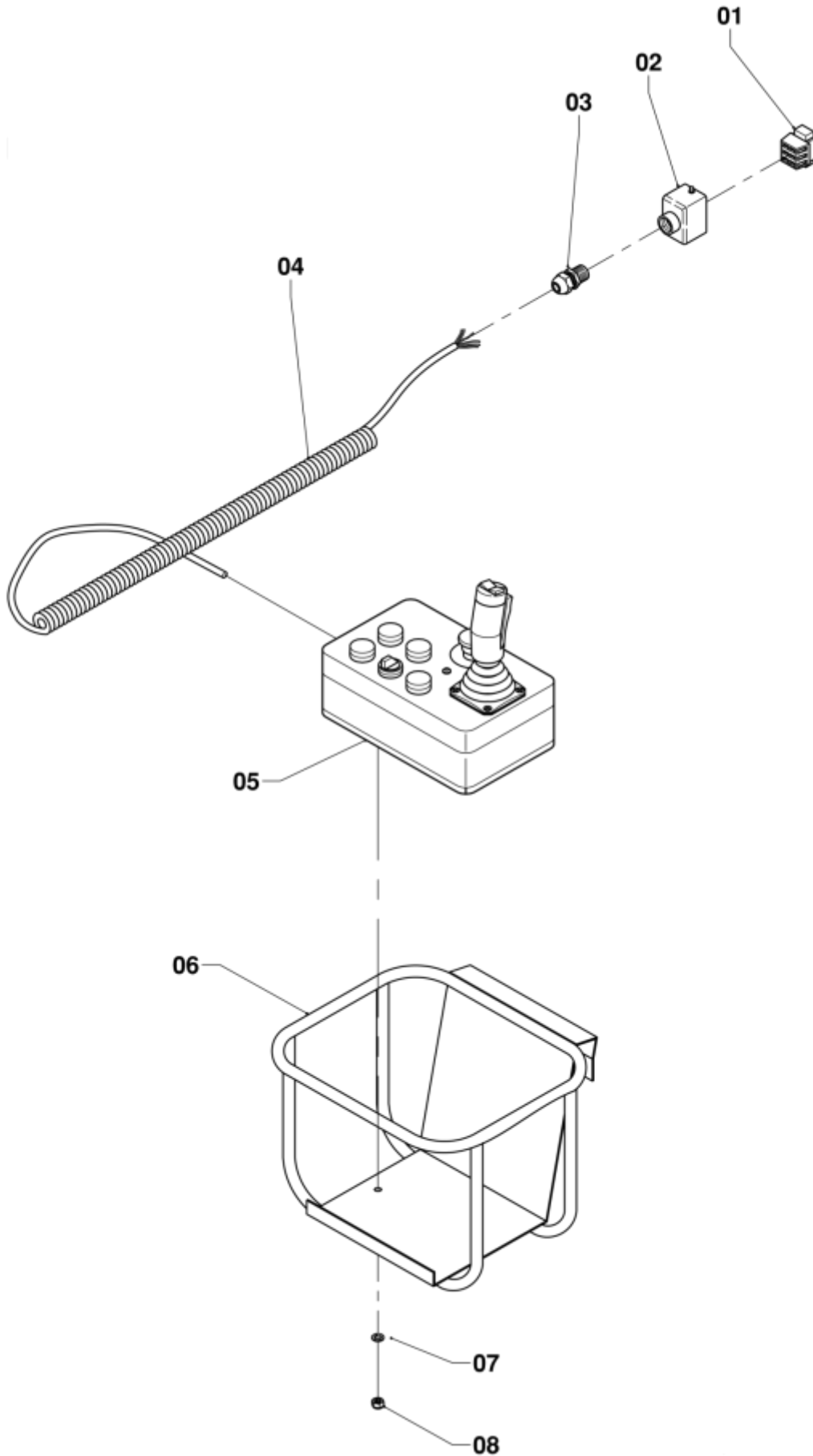

Item	Qty	Part number	Description
1	1	(See electric plan)	Plug, inner
2	1	(See electric plan)	Hood
3	2	- - - -	Cable gland
4	1	E/KAB TYPE2	Cable
5	1	(See electric plan)	Control box assembly
6	1	N-03-15	Protection bracket
7	2	38130.080.001	Washer, DIN 125-A
8	2	12300.080.001	Nut, DIN 985